



300,000 to 500,000 BTU/hr

Now with Front Venting & Improved Thermal Efficiency

Modulating Condensing Commercial Water Heaters

Up to 99% Thermal Efficiency by Modulating Fuel Input to Supply Variable Domestic Hot Water Demand

■ Five-Year Limited Tank/Heat Exchanger Warranty
– THE INDUSTRY'S FINEST

OptiTherm® for Optimal Thermal Efficiency:

- Maximum inputs from 300,000 to 500,000 BTU/hr
- Up to 6:1 turndown ratio
 - Fully modulating from as low as 80,000 BTU/hr
- 119/125 gallon capacities
- Up to 99% thermal efficiency
- **NEW** Front venting
- **NEW** Minimum gas supply pressure 3.5" WC (NAT) and 8" WC (LP)
- Automatic cathodic corrosion protection system
 - No sacrificial anode rods
- PVC/CPVC/ABS venting - 240' maximum power vent length
- LCD user interface with optional BMS interface
- Ecomate® insulation
- Glass-fused-to-steel water tank and heat exchanger
- SCAQMD certified Ultra-Low NOx
- Natural gas or propane fuel
- Stealth Quiet™ operation
- Fits through a 36-inch door
- Concentric vent kit available

Turboflue® High Performance Heat Exchanger:

- Patented helical-fin multi-stage design
- Superior heat conduction and fuel efficiency

Made in the USA



OPTITHERM®

BUILT LIKE A BOCK



OT300N2/OT400N2/OT500N2

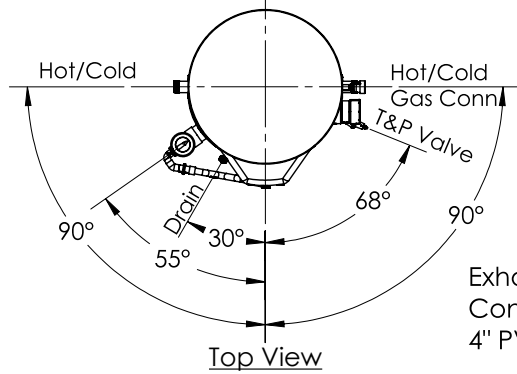

Exhaust Vent Conn./
Condensate Assembly
4" PVC

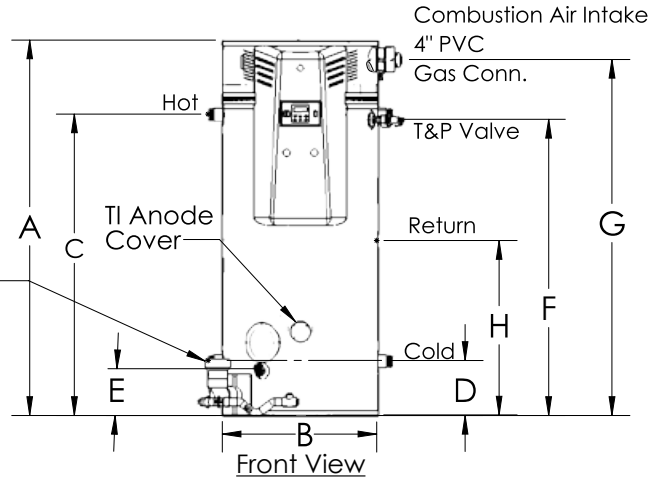

Minimum and Maximum Vent Lengths - 4" / 6" Pipe

Model	Pipe Arrangement	Minimum Equivalent Pipe Length (per pipe run)		Maximum Equivalent Pipe Length (per pipe run)	
		Air Intake (ft)	Vent (ft)	Air Intake (ft)	Vent (ft)
OT300N2/ OT400N2/ OT500N2	Power Direct Vent (2 Pipe)	20/50	20/50	50/120	50/120
	Power Vent (1 Pipe)	0/0	20/100	0/0	100/240

Storage, Inputs, Recovery & Efficiency

Model	Storage GAL (L)	Max. Rated Input BTU/HR (KW)	Min. Rated Input BTU/HR (KW)	Recovery @ 100°F Rise GAL/HR (L/HR)	1st Hr. Del. @ 100°F Rise GAL (L)	Thermal Efficiency @ Max Input (%)	Thermal Efficiency @ Min Input (%)
OT300N2-(A)	119/125 (473)	300,000 (87.9)	80,000 (23.4)	357 (1,351)	480 (1,817)	99	99
OT400N2-(A)	119/125 (473)	399,999 (117.2)	80,000 (23.4)	466 (1,764)	587 (2,222)	97	99
OT500N2-(A)	119/125 (473)	500,000 (146.5)	80,000 (23.4)	576 (2,180)	696 (2,635)	96	99

NOTE: OT 300/400/500 available with 119 gallon Non-ASME version.

Dimensions and Connections

Model	Dimensions in Inches (cm)								Cold NPT	Hot NPT	Recirc. Return NPT	Gas NPT	Air Intake PVC	Exhaust Vent PVC	Shipping Weight LBS (kg)
	A	B	C	D	E	F	G	H							
OT300N2-(A)	78.8 (200)	32.2 (81.8)	62.75 (159)	11.4 (29)	9.4 (24)	61.7 (156)	74.0 (188)	36.3 (9.2)	2"	2"	1"	1.5"	4"	4"	1,100 (500)
OT400N2-(A)	78.8 (200)	32.2 (81.8)	62.75 (159)	11.4 (29)	9.4 (24)	61.7 (156)	74.0 (188)	36.3 (9.2)	2"	2"	1"	1.5"	4"	4"	1,100 (500)
OT500N2-(A)	78.8 (200)	32.2 (81.8)	62.75 (159)	11.4 (29)	9.4 (24)	61.7 (156)	74.0 (188)	36.3 (9.2)	2"	2"	1"	1.5"	4"	4"	1,100 (500)

NOTE: Change the suffix from "N" to "LP" to designate liquid propane.

NOTE: "A" denotes ASME construction.

T&P valve and brass drain valve factory installed.

Standard Voltage (all): 120V, 60 Hz, 1P

Maximum Working Pressure: 150 psi (1034 kPa)

These models meet or exceed current ASHRAE standards.

Warning: Installation should be in accordance with all national and/or local codes. In the absence of local codes, refer to NFPA 54 or CSA B149.1.

Caution: The recommended maximum hot water temperature setting for normal residential use is 120°F. Bock recommends a tempering valve or anti-scald valve be installed and used according to the manufacturer's directions to prevent scalding.



(on selected models)



www.bockwaterheaters.com

110 South Dickinson Street Madison, Wisconsin 53703

Toll Free 800-794-2491 • Phone 608-257-2225 • Fax 608-257-5304

Doc# 80048 Rev. 10-20