

Removing and Replacing the Manifold/Burner Assembly

Removing the Manifold/Burner Assembly



Explosion Risk

▲ WARNING! Failure to follow these instructions can result in serious injury or death from explosion or fire.

- 1 Move the ON/OFF switch on the gas control valve/thermostat to the "OFF" position to turn off the water heater (Figure 1).

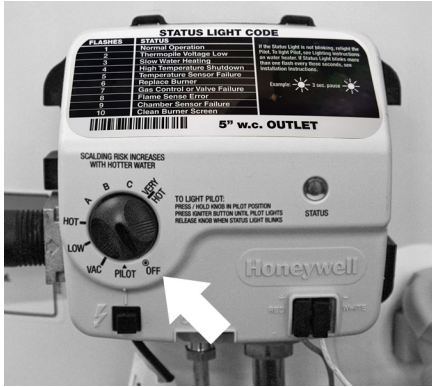

Figure 1: Gas valve in "off" position.

- 2 Turn off the gas to the water heater at the manual gas shut-off valve (Figure 2).



Figure 2: Turn the gas control valve off.

- 3 Remove the outer door.
- 4 Remove the manifold screws (1/4" nut driver) securing the manifold door to the combustion chamber (Figure 3).

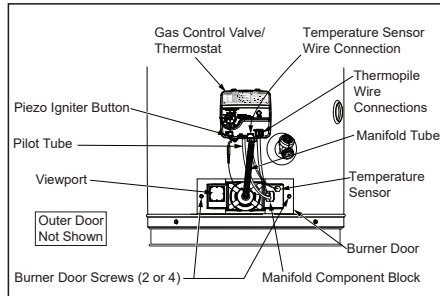

Figure 3: Front view of water heater with outer door removed.

- 5 Go to the gas control valve/thermostat and disconnect the pilot tube (7/16" wrench), igniter wire from the igniter lead wire, and manifold tube (3/4" wrench). Disconnect the sensor wire (lift white lever outward, then gently pull the plug downward). Disconnect the red (+) and white (-) Thermopile wires from the gas control valve/thermostat (See Figure 6).

- 6 Grasp the manifold tube and push down slightly to free the manifold and pilot tube.

- 7 Carefully remove the burner door assembly from the burner compartment. To reinstall it, see "Replacing the Manifold/Burner Assembly" below. **NOTICE:** Be sure not to damage internal parts.

Replacing the Manifold/Burner Assembly



Explosion Risk

▲ WARNING! Failure to follow these instructions can result in serious injury or death from explosion, fire or carbon monoxide poisoning.

- Tighten manifold door screws securely.
- Remove any fiberglass between gasket and combustion chamber.

- Replace viewport if glass is missing or damaged.
- Replace the manifold component block if it is missing or removed.
- Replace the door gasket if it is damaged.

- 1 Check the door gasket for damage or embedded debris prior to installation.
- 2 Inspect the viewport for damage and replace as required.
- 3 Insert the burner assembly into the burner compartment, making sure that the burner assembly sits firmly against the burner bracket and spring (if equipped) inside the combustion chamber. See Figure 4 for ring base heaters and Figure 5 for leg base heaters.

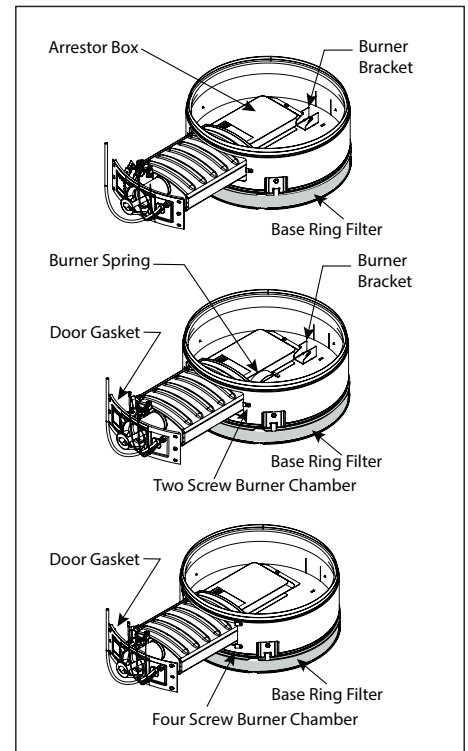

Figure 4: Ring Base Heaters

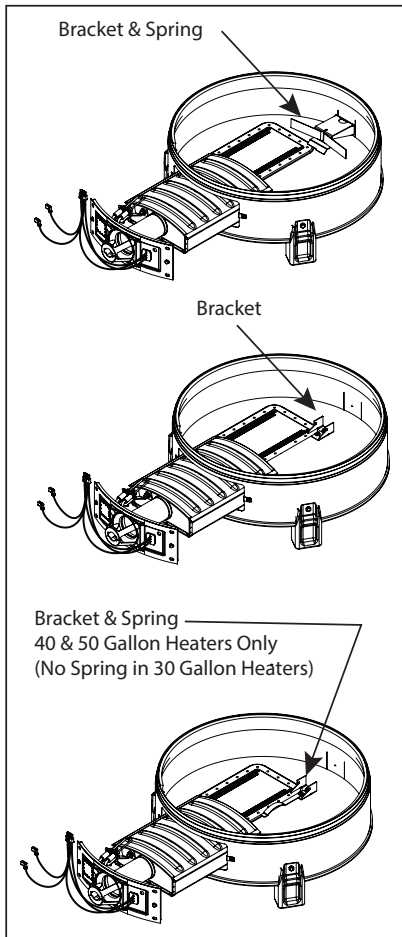

Figure 5: Leg Base Heaters

4 Inspect the door gasket and make sure there is no fiberglass insulation between the gasket and the combustion chamber.

5 Replace the screws which secure the burner assembly to the combustion chamber and tighten securely. There should be no space between the gasket part of the burner door and combustion chamber. **WARNING!** Do not operate the water heater if the door gasket does not create a seal between the burner door and the combustion chamber.

6 Reconnect the manifold tubing (3/4" wrench), pilot tubing (7/16" wrench), to the gas control valve/thermostat. Also connect the igniter wire, the red (+) and white (-) thermopile wires. (see Figure 6 for the correct position of each connection). Do not cross-thread or apply any thread sealant to the fittings.

- A** Igniter wire
- B** Thermopile wires/plug
- C** Pilot tube (7/16" wrench)
- D** Manifold tube (3/4" wrench)
- E** Temperature Sensor Wires

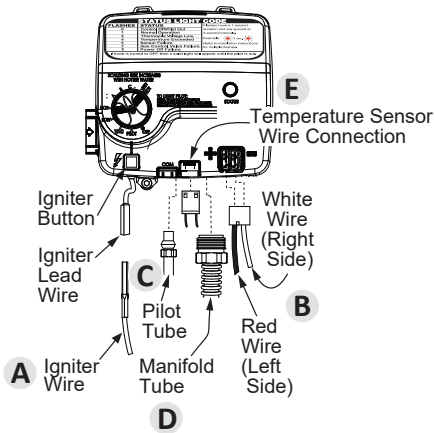

Figure 6: Gas valve connections.

7 Reconnect the temperature sensor wires.

8 Follow the "Lighting Instructions." These instructions can be found in the use and care guide or on the water heater's labeling.

9 Check for leaks **with the main burner on** by brushing on an approved noncorrosive leak detection solution. Bubbles forming indicate a leak. Correct any leak found. **IMPORTANT:** All leaks must be fixed immediately.

10 Replace the outer door.