



# LANCASTER

## WATER TREATMENT

### INSTALLATION, OPERATING AND SERVICE MANUAL



## ULTRAVIOLET DISINFECTION SYSTEM

### 7-LWT-UV410-009

**PLEASE CAREFULLY READ INSTRUCTIONS BEFORE INSTALLING SYSTEM**

**FOLLOW ALL STATE AND LOCAL CODES AND REGULATIONS FOR PLUMBING AND ELECTRICAL.  
INSTALLATION BY A CERTIFIED PLUMBER IS RECOMMENDED.**

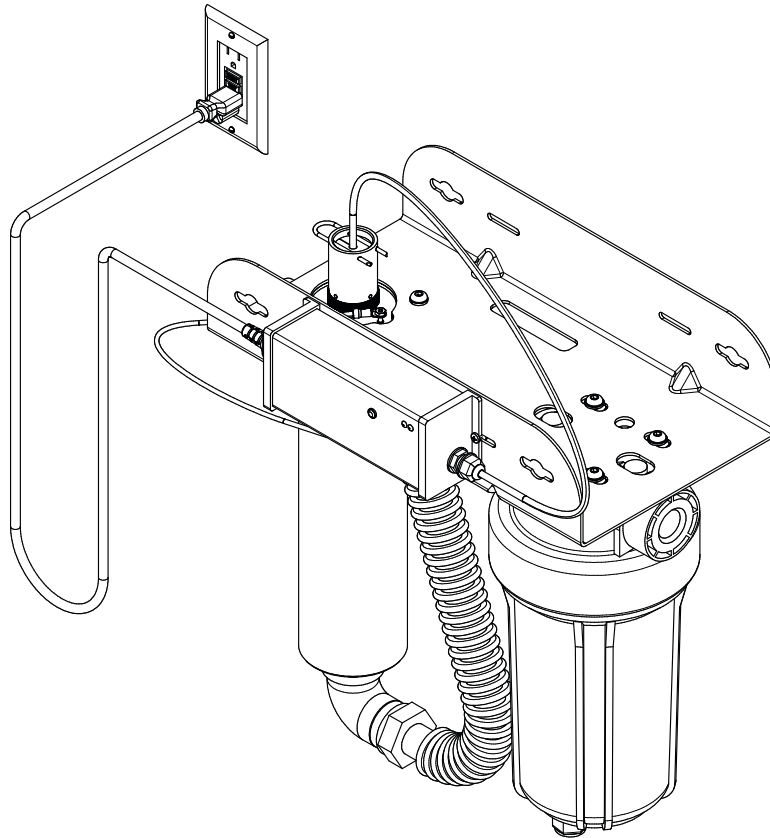

Congratulations on purchasing your new **Lancaster Water UV Disinfection System**. This unit is designed to give you many years of trouble free service. For servicing and future inspection purposes, please file this booklet with your important documents.

In the event that you need assistance for servicing your UV system, please first contact the professional contractor who installed the system.

# PLEASE CAREFULLY READ INSTRUCTIONS BEFORE INSTALLING SYSTEM

FOLLOW ALL STATE AND LOCAL CODES  
AND REGULATIONS FOR PLUMBING AND ELECTRICAL.  
INSTALLATION BY A CERTIFIED PLUMBER IS RECOMMENDED.

## Safety Instructions:

### **DANGER**

Failure to follow these instructions will result in serious injury or death.

- **Electric Shock:** To avoid possible electric shock, special care should be taken since water is present near the electrical equipment. Unless a situation is encountered that is explicitly addressed by the provided maintenance and troubleshooting sections, DO NOT attempt repairs yourself, refer to a certified plumber/technician.
- **GROUNDING:** This product must be grounded. If it should malfunction or breakdown, grounding provides a path of least resistance for electric current to reduce the risk of electrical shock. This system is equipped with a cord having an equipment-grounding conductor and a grounding plug. The plug must be plugged into an appropriate outlet that is properly installed and grounded in accordance with all local codes and regulations. Improper connection of the equipment-grounding conductor can result in a risk of electrocution. Check with a qualified electrician if you are in doubt as to whether the outlet is properly grounded. DO NOT modify the plug provided with this system – if it does not fit in the outlet, have a proper outlet installed by a qualified electrician. DO NOT use any type of adapter with this system.
- **GROUND FAULT CIRCUIT INTERRUPTER PROTECTION:** To comply with the National Electrical Code (NFPA 70) and to provide additional protection from the risk of electric shock, this system should only be connected to a properly grounded, grounding-type receptacle that is protected by a Ground Fault Circuit Interrupter (GFCI) or to a residual current device (RCD) having a rated residual operating current not exceeding 30 mA. Inspect operation of GFCI as per manufacturer's suggested maintenance schedule.
- DO NOT operate the disinfection system if it has a damaged cord or plug, if it is malfunctioning or if it has been dropped or damaged in any manner.
- DO NOT use this disinfection system for other than intended use (potable water applications). The use of attachments not recommended or sold by the manufacturer / distributor may cause an unsafe condition.
- DO NOT install this disinfection system where it will be exposed to the weather or to temperatures below freezing.
- DO NOT store this disinfection system where it will be exposed to the weather.
- DO NOT store this disinfection system where it will be exposed to temperatures below freezing unless all water has been drained from it and the water supply has been disconnected.



### **WARNING**

- During extended periods of no water flow, the water in your chamber can become very hot and potentially lead to scalding. It is recommended to run your water until this hot water has been purged from your chamber. Do not allow water to contact your skin during this time.
- This system contains a UV Lamp. Do not operate the UV Lamp when it is removed from the chamber. Unintended use or damage of the system may result in the exposure of dangerous UV radiation. UV radiation may, even in little doses, cause serious burns to the unprotected eyes and skin. NEVER look directly at the UV Lamp when in operation. Disconnect power before servicing or replacing the UV Lamp.
- Changes or modifications made to this system without the consent of the manufacturer could render the system unsafe for operation and may void the manufacturer's warranty.



## ⚠ CAUTION

Failure to follow these instructions could result in minor or moderate injury.



- Carefully examine the disinfection system after installation. It should not be plugged in if there is water on parts not intended to be wet such as, the electronic ballast controller or lamp connector.
- Due to thermal expansion concerns and potential material degradation due to UV exposure, it is recommended to use metal fittings and at least 10" of copper pipe on the outlet of your UV chamber.
- **Hg EXPOSURE:** The UV lamp contains mercury. If the lamp breaks, then avoid inhalation or ingestion of the debris and avoid exposure to eyes and skin. Never use a vacuum cleaner to clean up a broken lamp as this may scatter the spilled mercury. Obey local regulations and guidelines for the removal and disposal of mercury waste.

## NOTICE



- The UV lamp inside the disinfection system is rated at an effective life of approximately 9000 hours. To ensure continuous protection, replace the UV lamp annually.
- This system is intended to be permanently connected to the water lines.
- This system is not intended to be used in or above water or outdoors or used in swimming pools when persons are in the pool.
- **EXTENSION CORDS:** If an extension cord is necessary, use only 3-wire extension cords that have 3-prong grounding-type plugs and 3-pole cord connectors that accept the plug from this system. Use only extension cords that are intended for outdoor use. Use only extension cords having an electrical rating not less than the rating of the system. A cord rated for less amperes or watts than this system rating may overheat. Exercise caution when arranging the cord so that it will not be tripped over or pulled. **DO NOT** use damaged extension cords. Examine extension cord before using and replace if damaged. **DO NOT** abuse extension cord. Keep extension cord away from heat and sharp edges. Always disconnect the extension cord from the receptacle before disconnecting this system from the extension cord. Never yank cord to pull plug from outlet. Always grasp the plug and pull to disconnect.
- If the electronic ballast power cord is damaged, it must be replaced by a special cord or assembly available from the manufacturer or its service agent.
- A dedicated circuit breaker must not exceed the electronic ballast power cord current rating (10A for 125V, 18AWG x 3C, SVT or SJT cord type).
- Read and understand this Manual before operating and performing any maintenance on this equipment.
- Save these instructions:

### Water Chemistry:

Water quality is extremely important for the optimum performance of your UV system. The following levels are recommended for installation:

- **Iron:** < 0.3 ppm (0.3 mg/L)
- **Hardness\*:** < 7 gpg (120 mg/L)
- **Turbidity:** < 1 NTU
- **Manganese:** < 0.05 ppm (0.05 mg/L)
- **Tannins:** < 0.1 ppm (0.1 mg/L)
- **UV Transmittance:** > 75% (call factory for recommendations on applications where UVT < 75%)

\*Where total hardness is less than 7 gpg, the UV unit should operate efficiently provided the quartz sleeve is cleaned periodically. If total hardness exceeds 7 gpg, the water should be softened. If your water chemistry contains levels in excess of those mentioned above, proper pre-treatment is recommended to correct these water problems prior to the installation of your UV disinfection system. These water quality parameters can be tested by your local dealer, or by most private analytical laboratories. **Proper pre-treatment is essential for the UV disinfection system to operate as intended.**

# PRODUCT OVERVIEW:

Please read this manual thoroughly for a detailed explanation of the system.

The following is a description of the components that make up the system.

Ensure that the following components accompany the system .

To ensure system performance, all replacement components should be purchased from an authorized dealer or directly from Lancaster Water Treatment.

The use of components purchased from other sources will void the warranty and could cause the system to operate at a lower performance than intended.

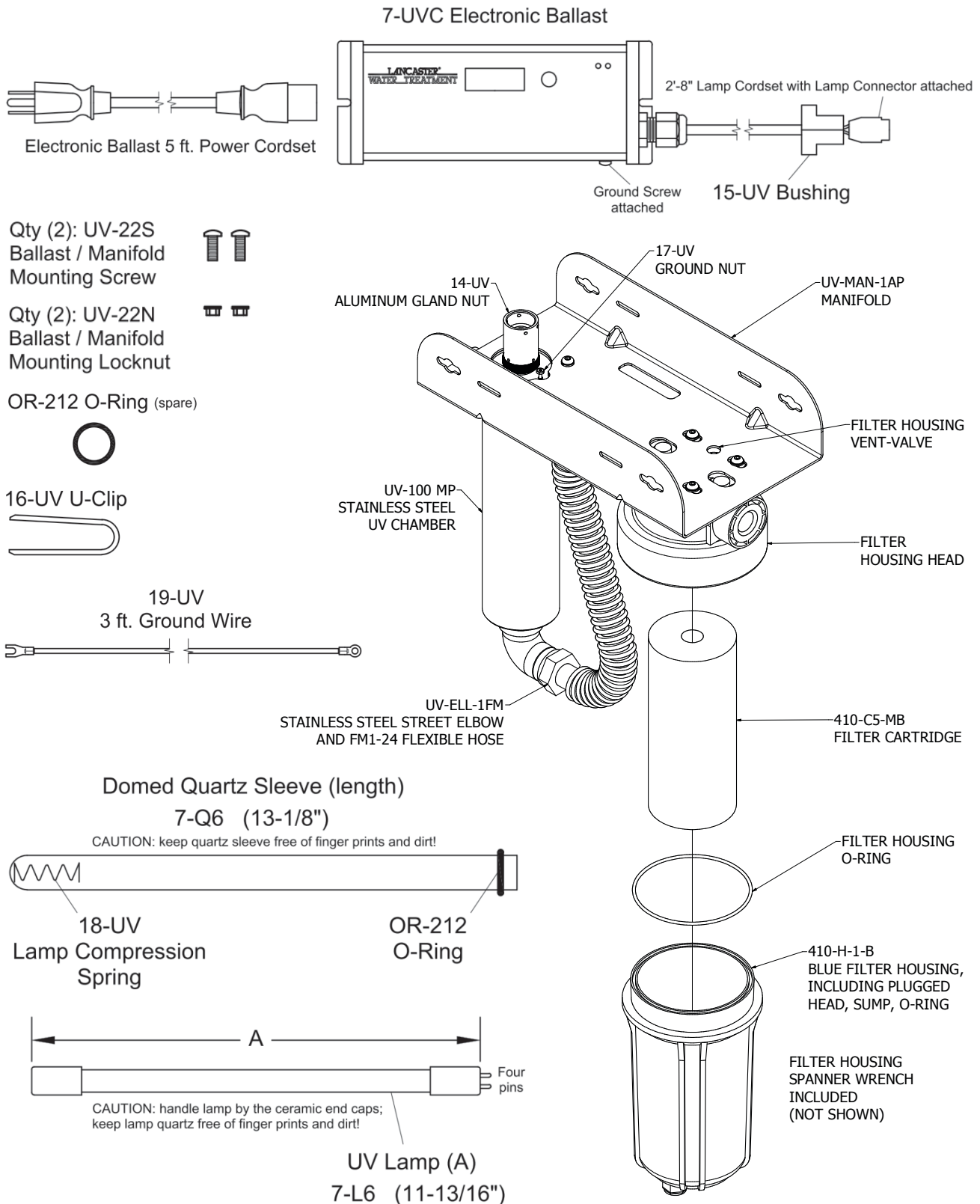

# ASSEMBLY:

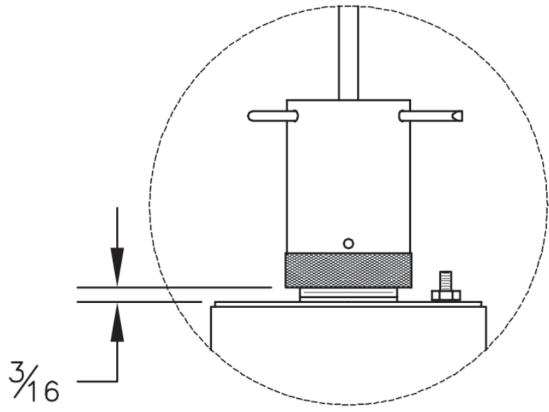
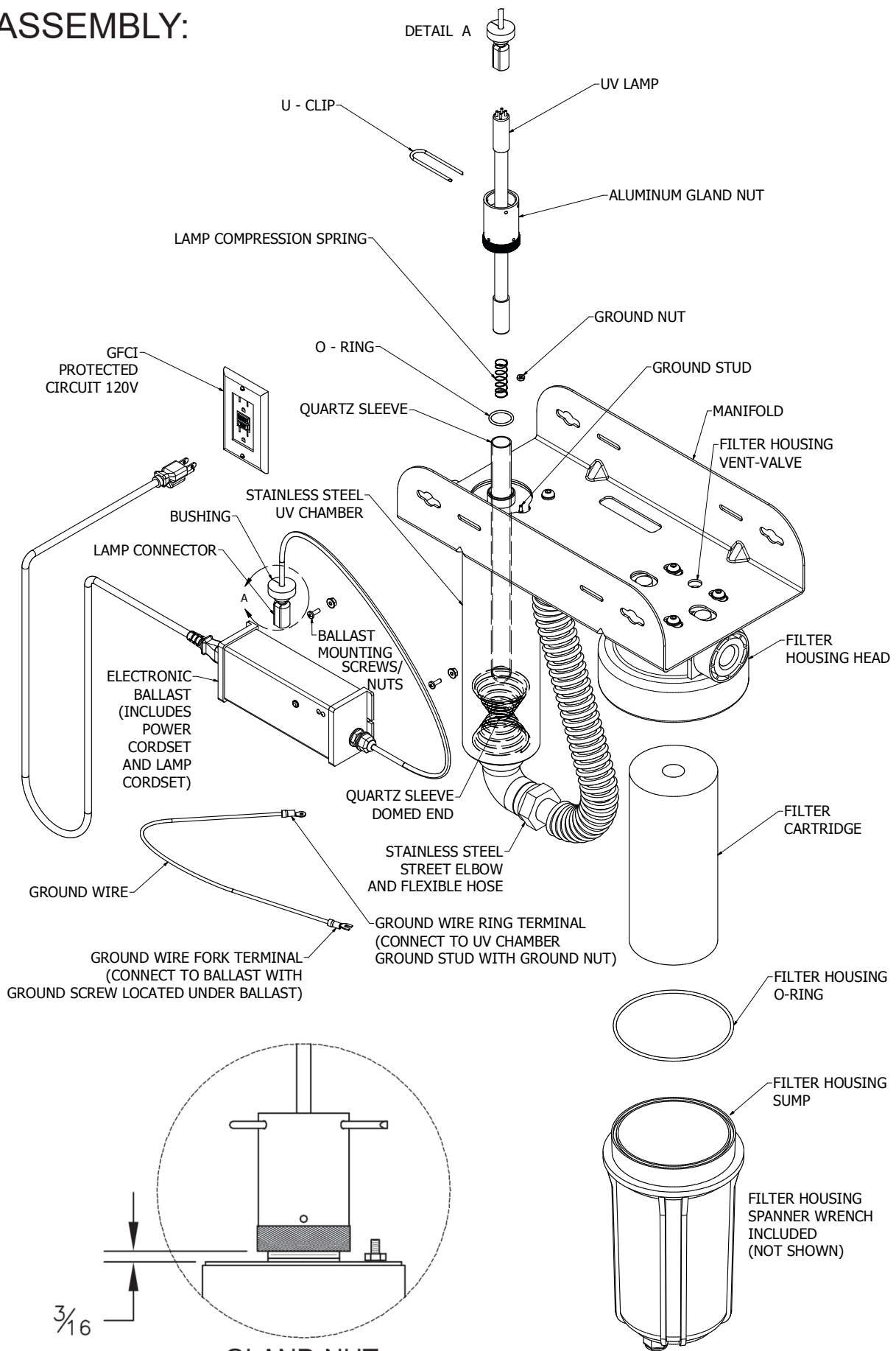

GLAND NUT  
HAND-TIGHT  
ASSEMBLY  
ENLARGED VIEW

# DIMENSIONS:

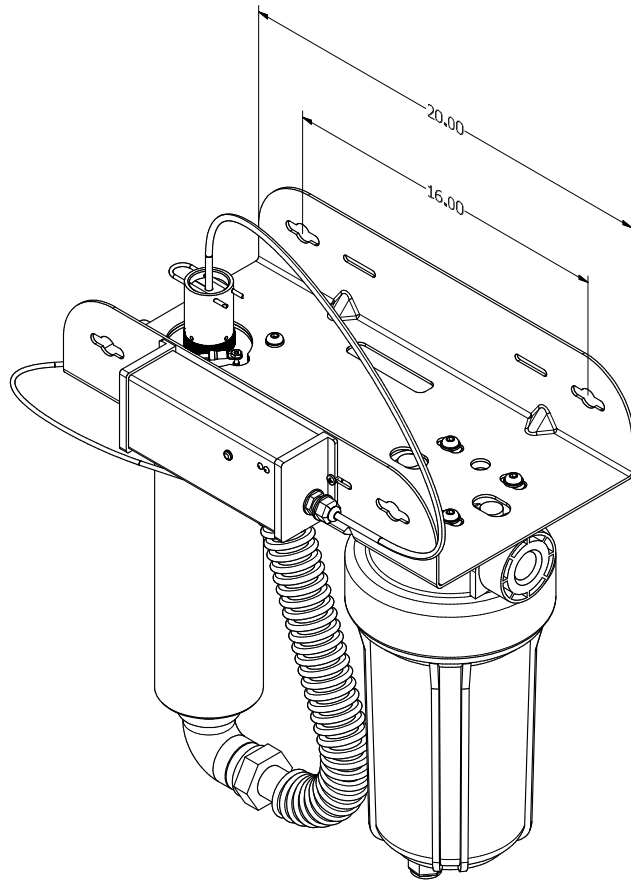

GENERAL NOTES FOR ESTIMATING ONLY.  
ALL DIMENSIONS ARE IN INCHES.

WEIGHT: 22 LBS

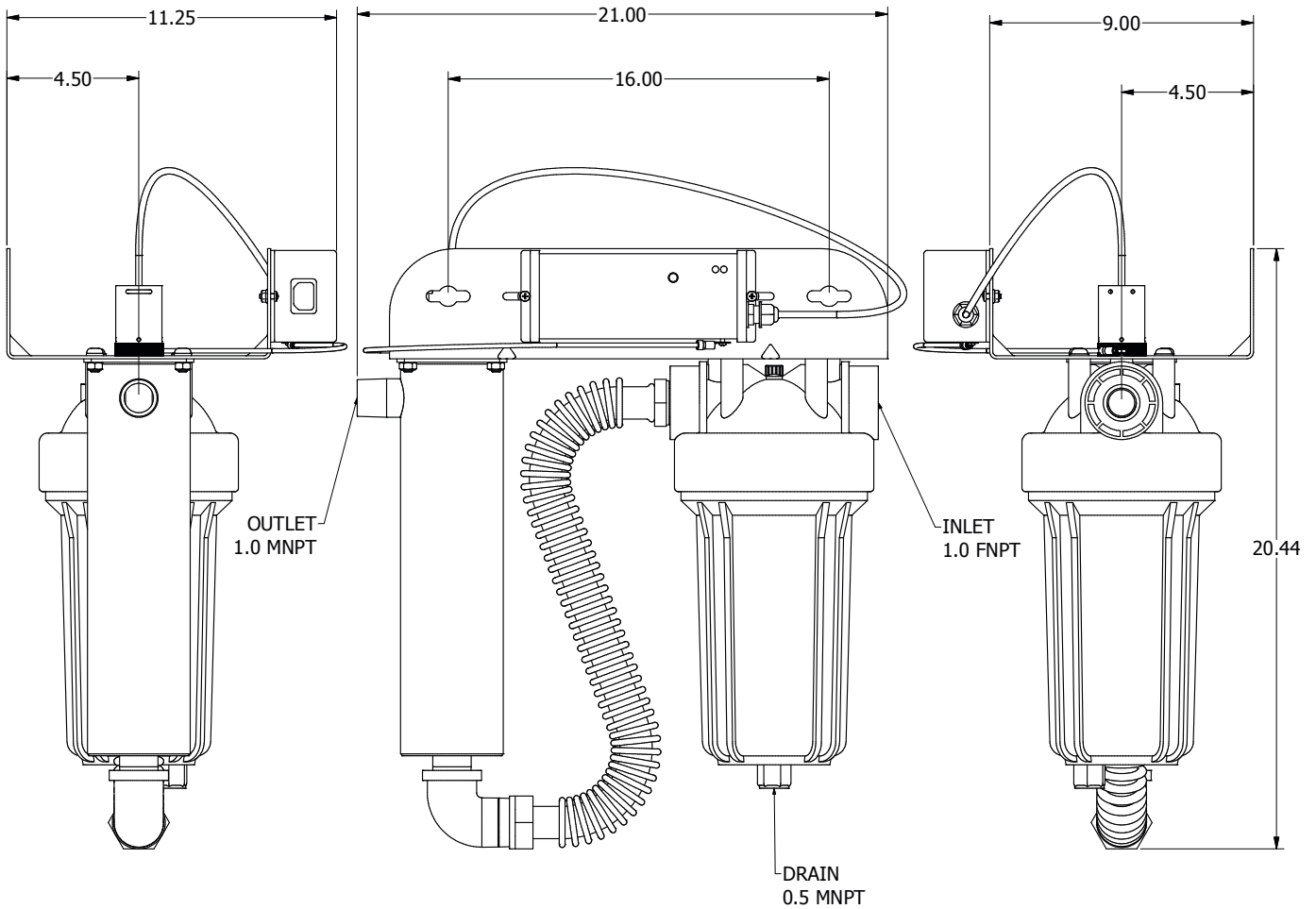

# SPECIFICATIONS:

	FLUENCE (UV DOSE)	MODEL 7-LWT-UV410-009
FLOW RATE <sup>(1)</sup>	US PUBLIC HEALTH 16mJ/cm <sup>2</sup>	17 GPM
	INDUSTRY STANDARD 30mJ/cm <sup>2</sup>	9 GPM
	NSF/EPA 40mJ/cm <sup>2</sup>	7 GPM
ELECTRICAL	VOLTAGE <sup>(2)</sup>	110V to 240V AC 50/60Hz
	POWER CONSUMPTION	34 W
	LAMP WATTS	29 W
INLET / OUTLET PORT SIZE	1.0" FNPT FILTER HOUSING HEAD INLET / 1.0" MNPT UV CHAMBER OUTLET	
MAX / MIN OPERATING PRESSURE	120 PSI / 7.25 PSI	
PRESSURE DROP at 30mJ/cm <sup>2</sup> RATED FLOW	APPROX. 1.5 PSI (NEW 410-C5-MB FILTER CARTRIDGE) + LESS THAN 1 PSI (UV CHAMBER) = LESS THAN 3 PSI TOTAL	
AMBIENT AIR & WATER TEMPERATURE	36 to 104°F	
FILTER CARTRIDGE TYPE	5 MICRON NOMINAL, 4.50" OD x 10" NOMINAL HEIGHT, PP MELT-BLOWN SMOOTH WITH DOE	
FILTER HOUSING MATERIAL	REINFORCED PP HEAD AND BLUE BOWL, PP VENT VALVE BODY, EPDM O-RINGS	
LAMP TYPE	LOW PRESSURE HIGH OUTPUT (LPHO)	
UV CHAMBER MATERIAL	304 SS	
LAMP-ON INDICATOR	STEADY "WORK" GREEN LED	
LAMP LIFE REMAINING (DAYS)	VISUAL COUNT DOWN DISPLAY (365 - 0); MANUAL RESET FUNCTION	
LAMP REPLACEMENT REMINDER	VISUAL DISPLAY (A3), "FAULT" RED LED FLASHES and AUDIBLE ALARM SOUNDS INTERMITTENTLY (1 SEC. BEEP EVERY 5 SEC.)	
LAMP REPLACEMENT REMINDER DELAY	SILENCES AUDIBLE ALARM FOR 7 DAYS, REPEATABLE UP TO 4 TIMES (28 DAYS MAXIMUM)	
LAMP FAILURE INDICATOR	LAMP LIFE REMAINING (DAYS) CONTINUES TO BE DISPLAYED BUT STOPS COUNTING DOWN, "FAULT" RED LED FLASHES and AUDIBLE ALARM SOUNDS INTERMITTENTLY (1 SEC. BEEP EVERY 1 SEC.)	
BALLAST TOTAL RUNNING DAYS	VISUAL INCREMENTAL DISPLAY (0 - 9999); CANNOT BE RESET	
BALLAST FAILURE INDICATOR	BLANK DISPLAY	

(1) At flow rates stated, the corresponding fluence (UV dose) levels are theoretically met or exceeded at 95% UVT and EOL (end of lamp life; 1 year). **UVCalc**<sup>®</sup>, developed by Bolton Photosciences Inc., is based on calculations of fluence rates (irradiances) using the multiple point source summation approximation with full accommodation of reflection and refraction occurring at the air/quartz/water interface and is the only mathematical fluence rate model that has been experimentally verified. Contact LANCASTER WATER TREATMENT for references.

(2) Models are supplied with a 5 FT. power cordset for 120V AC 60 Hz (NEMA 5-15P plug to IEC 60320/C13 connector).

## Installing your UV Disinfection System:

# ⚠ CAUTION



The electronic ballast must be connected to a Ground Fault Protected Circuit (GFCI) receptacle. Ensure the green ground wire ring terminal is securely fastened to the UV chamber ground stud using its ground nut. Ensure the green ground wire fork terminal is securely fastened to the electronic ballast using its ground screw.

The disinfection system is designed to be installed at point-of-entry. Drip loops in all cordage connected to the electronic ballast is highly recommended. Refer to installation diagram below.

- The complete water system including any pressure or hot water tanks, must be sterilized before start up by flushing with chlorine (household bleach) to destroy any residual contamination. Refer to Disinfection Procedure Section.
- For safety purposes, the disinfection system must be connected to a Ground Fault Protected Circuit (GFCI).
- The disinfection system is intended for indoor use only. Do not install disinfection system where it may be exposed to the weather. Protect system from freezing temperature.
- Refer to specifications page for ambient conditions and maximum operating pressure.
- Install the disinfection system on cold water line only.
- If treating the entire house, install the disinfection system before any branch lines.

### PROCEDURE:

1. The diagram below shows the installation of a typical drinking water system and the related components that may be used for the installation. The use of a bypass assembly is recommended in case the system requires “off-line” maintenance. If this is the case, it must be noted that the system will require supplementary disinfection of the distribution system if any water is used during this bypass condition. In addition, during bypass, the water will NOT be disinfected and a “DO NOT CONSUME THE WATER” tag should be physically installed on the bypass assembly until such time as the system is sanitized and returned to service. Please refer to the Disinfection Procedure Section for the complete disinfection procedure. If the water is to be consumed while the system is off-line, the water must be brought to a rolling boil for at least one minute before consumed. At higher altitudes, boiling should be extended to 3 minutes. Refer to public health boil-water advisory recommendations.

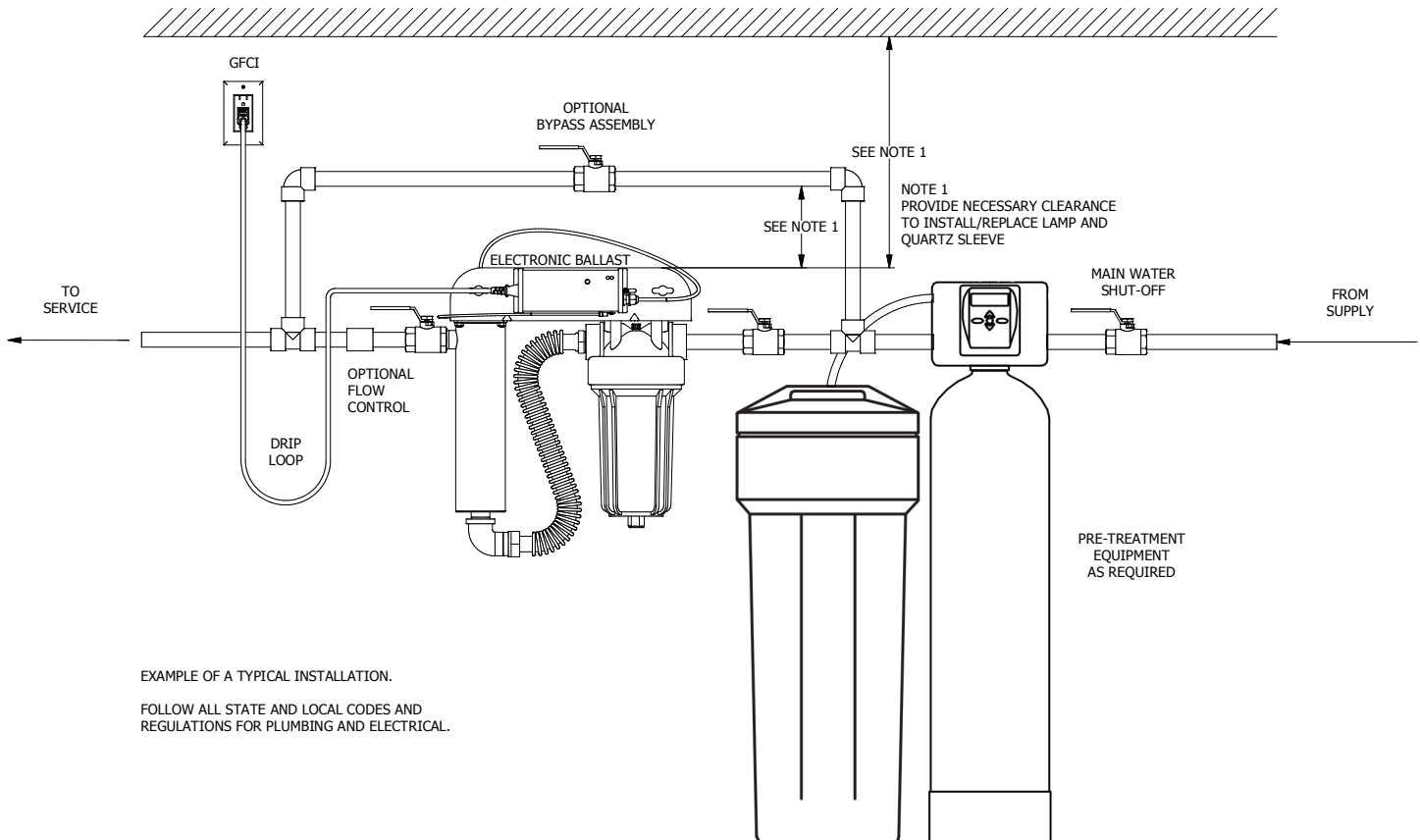



2. Select a suitable location for the disinfection system and its related components. As it is recommended to install a ground fault protected circuit (GFCI), make sure that this is taken into consideration prior to any installation. When selecting a mounting location, you must also leave enough space to allow for the removal of the UV lamp and/or quartz sleeve, as well as enough space to change out the filter cartridge.
3. Install the quartz sleeve as shown on assembly page 5. Keep quartz sleeve free of finger prints and dirt. Make sure the small lamp compression spring is inside the sleeve. Carefully insert sleeve into the UV chamber (do not drop) until the sleeve domed end seats in the center of the hourglass retainer spring located in the bottom end of the chamber. Install o-ring onto the sleeve until it is positioned against the chamfered seat. Install the aluminum gland nut on the UV chamber by turning clockwise and **hand-tighten only**.
4. Mount the system to the wall with appropriate lag screws (not supplied) through the two mounting holes located on the metal manifold. Refer to page 6 for dimensions and weight. Various connection methods can be used to connect the water source to the system, however due to thermal expansion concerns and potential material degradation due to UV exposure, it is recommended to use metal fittings and at least 10" of copper pipe on the outlet of your UV chamber. The use of a flow restrictor device is strongly recommended when installing your system in order to maintain the manufacturer's rated flow rate. The flow restrictor should be installed on the outlet port and is designed to be installed in one direction only. Ensure that the flow of the water matches the flow direction as indicated on the flow restrictor. **DO NOT SOLDER CONNECTIONS WHILE ATTACHED TO THE SYSTEM AS THIS COULD DAMAGE THE O-RING SEALS.**
5. Mount the electronic ballast controller onto the metal manifold as shown on assembly page 5. A ground stud and nut are provided on the UV reactor chamber. Attach the supplied 3 foot long, #14 AWG green ground wire to this ground stud using the ring terminal end. Attach the fork terminal end of the ground wire to the electronic ballast controller ground screw.
6. Install the UV lamp as shown on assembly page 5. Handle the lamp by the ceramic end caps; keep lamp quartz surface free of finger prints and dirt. Carefully insert the lamp into the UV vessel (actually inside the quartz sleeve); leave approximately two inches of the lamp protruding from the chamber and attach the lamp connector to the UV lamp. Make sure the connector is fully seated on the lamp. Slide the connector and bushing into the aluminum gland nut. Gently press down on the bushing and squeeze/slide the U clip through the gland nut's four upper holes (2 pair, 180° apart).
7. Install the filter cartridge as shown on assembly page 5.
8. When all plumbing connections are made, slowly turn on the water supply and check for leaks. The most likely cause for leaks is from the o-ring seals. In case of a leak at the UV chamber, shut water off, drain chamber, remove gland nut assembly, wipe the o-ring and threads clean and re-install. In case of a leak at the filter, shut off water, vent/drain and remove sump, wipe o-ring and threads clean, ensure the o-ring is properly seated, then reinstall.
9. Once it is determined that there are no leaks, plug the system into the GFCI, and check electronic ballast controller to ensure the system is operating properly. The controller is designed to detect both power to the system and lamp illumination. It is important to **NEVER LOOK DIRECTLY AT THE GLOWING UV LAMP.**
10. Allow the water to run for a few minutes to clear any air or dust that may be in the UV chamber.

**PLEASE NOTE:** When there is no flow, the water in the chamber will become warm, as the UV lamp is always on. To remedy this, run a cold water tap anywhere in the house for a minute to flush out the warm water.

## Disinfection Procedure:

UV disinfection is a physical disinfection process and does not add any potentially harmful chemicals to the water. As UV does not provide a disinfection residual, it is imperative that the entire distribution system located after the UV be chemically disinfected to ensure that the water is free from any bacteriological contaminants. The disinfection process must be performed immediately after the UV unit is installed and repeated thereafter whenever the UV is shut down for service, without power, or inoperative for any reason. The procedure for sanitizing the plumbing system is readily accomplished as follows:

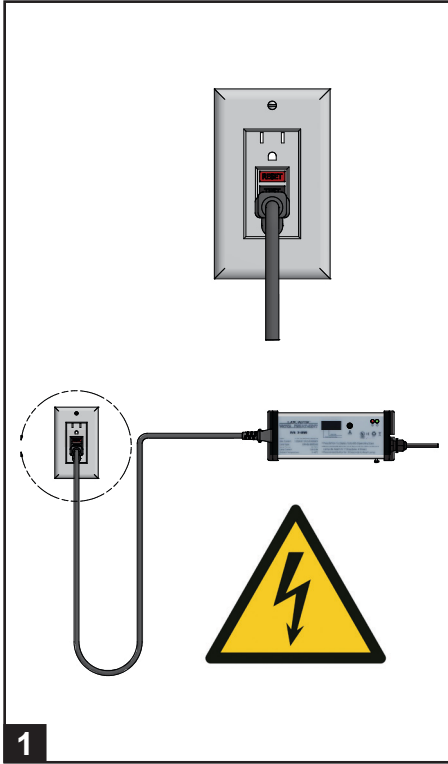

1

- Ensure the electronic ballast controller is plugged in for entire disinfection process.

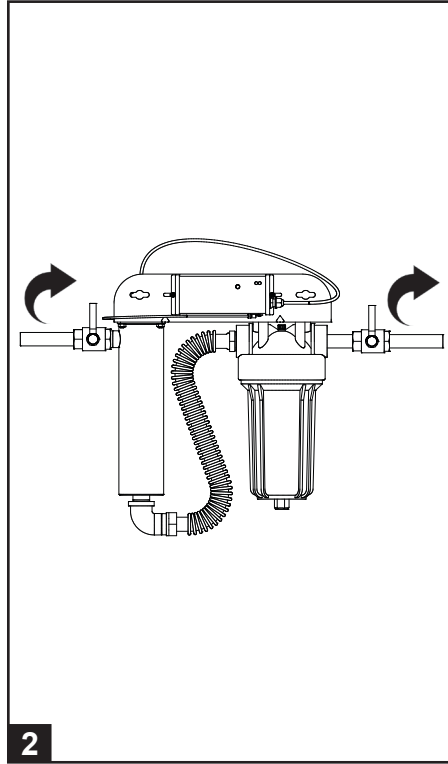

2

- Shut off the water supply.
- Close each valve.

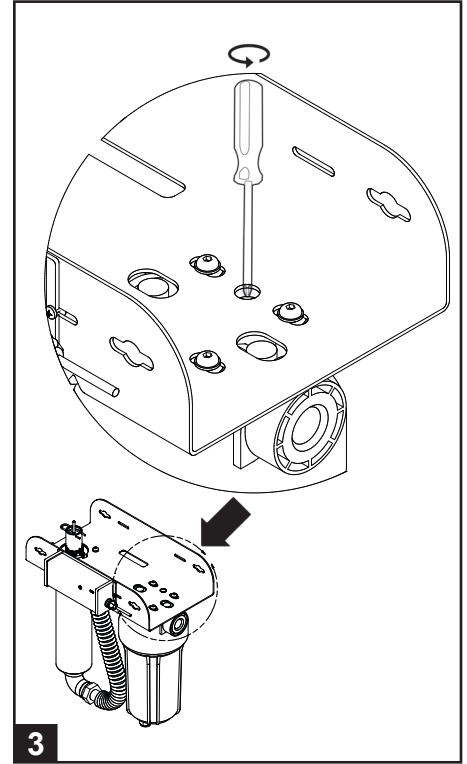

3

- Slowly and partially open vent to release the pressure from the filter.

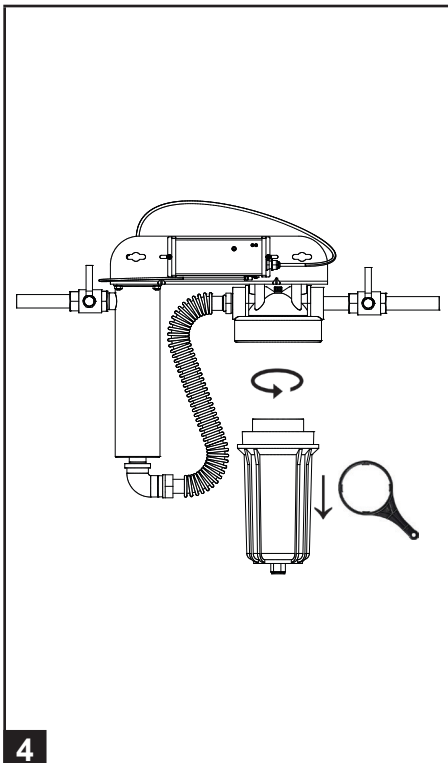

4

- Remove sump housing using sump wrench.

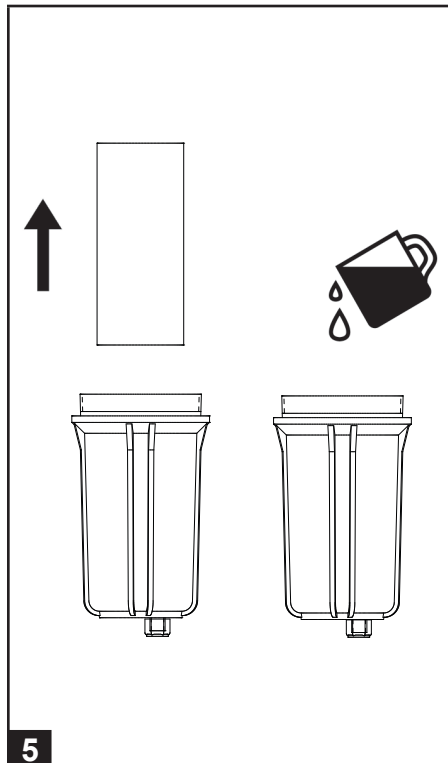

5

- Remove cartridge and pour 2 cups of household bleach solution into the sump housing.

**Note:** DO NOT use Hydrogen Peroxide.

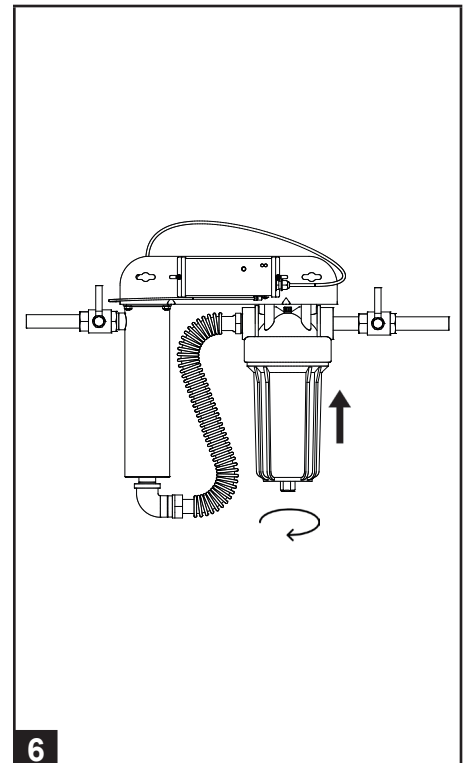

6

- Connect only the sump housing to the unit.

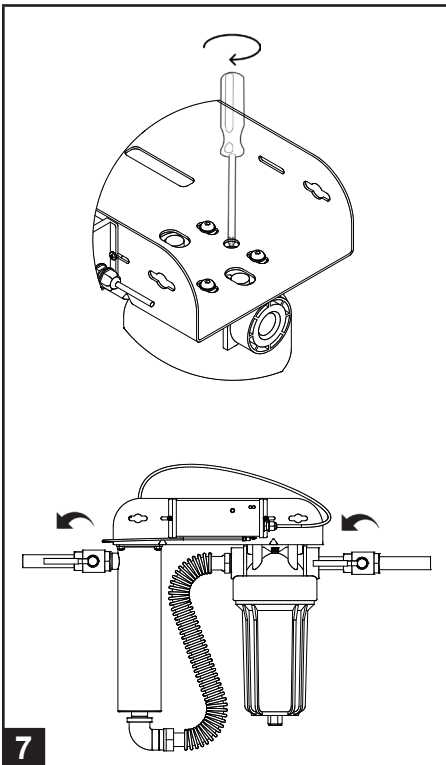

7

- Make sure vent is closed.
- Turn on water supply.
- Allow water to fill the chamber.

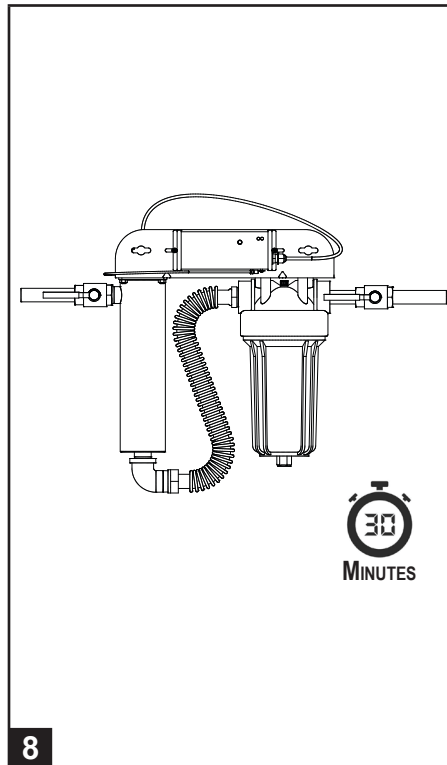

8

- Turn on the cold water supply faucets followed by hot water until you smell the bleach. You must ensure that all taps, including outside faucets, dishwasher, shower heads, washing machines, connection to refrigerators, toilets, etc. pass the bleach solution.
- Close all faucets and allow bleach to settle in the water lines for 30 minutes.

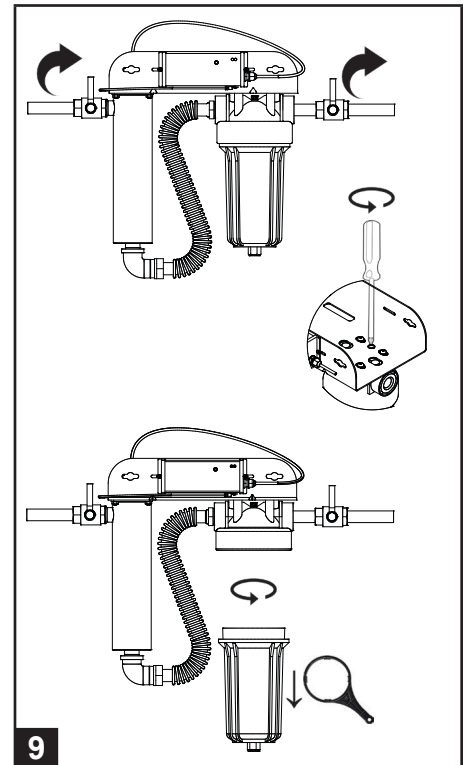

9

- With valves closed, vent pressure and remove sump housing using sump wrench.

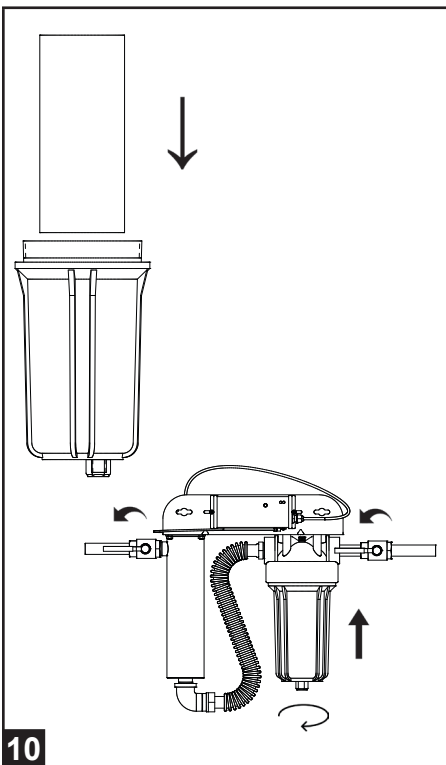

10

- Reinstall the cartridge into sump housing and connect to the unit.
- Open valves and flush all water outlets until bleach can no longer be smelled (at least 5 minutes).

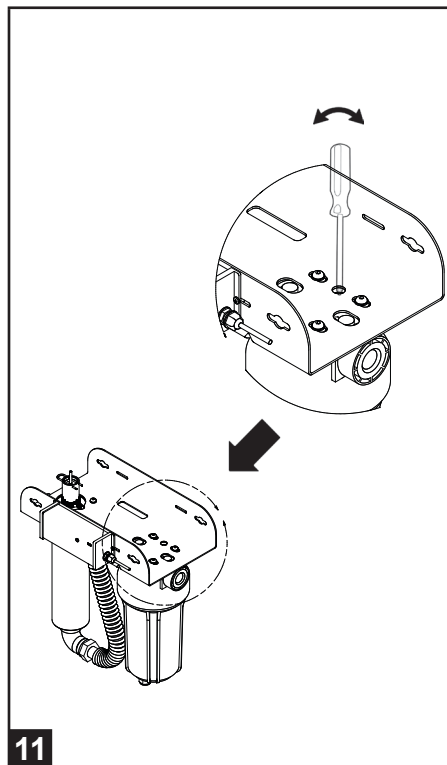

11

- Vent to purge air and to complete the disinfection procedure.

**Notes:**

1. Household bleach's main constituent is 5.25% sodium hypochlorite (liquid chlorine). The addition of chlorine to a hot water tank that has in the past been fed with untreated raw water with high levels of other contaminants (iron, manganese, hydrogen sulphide, organics, etc.) will result in oxidation of these contaminants and may require repeated flushing of the hot water tank. This contingency must be dealt with independently under the start-up procedure for any other conditioners that may form a part of the pre-treatment for the UV unit.
2. This disinfection procedure will result in a massive chlorine residual far in excess of the 0.5 to 1.0 mg/L typically present in municipally chlorinated water and of a magnitude consistent with the minimum 50 mg/L chlorine solution recommended for the disinfection of distribution systems known to be contaminated. Do not consume water until complete system has been flushed.

## Maintenance Instructions:

# ⚠ WARNING



- Always disconnect power before performing any work on the disinfection system.
- Always shut-off water flow and release water pressure before servicing.
- Regularly inspect your disinfection system to ensure that the power indicators are on and no alarms are present.
- Replace the UV lamp annually (or biennially if seasonal home use) to ensure maximum disinfection.
- Always drain the chamber when closing a seasonal home or leaving the unit in an area subject to freezing temperatures.

## UV LAMP REPLACEMENT:

# NOTICE

- Reset lamp life timer after lamp replacement. Refer to page 15. Refer to [www.lamprecycle.org](http://www.lamprecycle.org) for UV lamp disposal.
- Do not use water during replacement of UV lamp.

1. To replace the lamp, there is NO need to disconnect the system from the water supply, nor to drain the water from the UV chamber. **DO NOT USE WATER DURING THIS PROCEDURE.** Lamp replacement is a quick and simple procedure requiring no special tools. The UV lamp must be replaced after 9,000 hours of continuous operation (approximately one year) in order to ensure adequate disinfection. **Refer to the assembly diagram on page 5.**
2. Unplug the electronic ballast from the electrical outlet and allow the lamp to cool for at least 5 minutes before removing. Pull out the U clip from the gland nut. Remove bushing, connector and lamp from the UV chamber. Separate the lamp from the connector. Do not twist the lamp from the connector, simply slide the two apart. Avoid touching the lamp's quartz surface. Handling the lamp at the ceramic ends is acceptable, however if you must touch the lamp quartz, please use gloves or a soft cloth. Fully remove the lamp from the reactor chamber being careful not to angle the lamp as it is removed from the chamber. If the lamp is removed on an angle, pressure will be applied on the inside of the quartz sleeve, causing the sleeve to fracture.
3. To install a new lamp, first remove the lamp from its protective packaging, again being careful not to touch the lamp's quartz surface. Oil deposits from your fingers can create hot spots on the surface which may lead to premature lamp failure. Handle the lamp by the ceramic ends only. If the quartz surface becomes dirty, use a lint-free cloth and isopropyl alcohol to remove dirt. Carefully insert the lamp into the UV vessel (actually inside the quartz sleeve). Insert the lamp fully into the chamber leaving about two inches of the lamp protruding from the chamber. Next, attach the connector to the UV lamp. Ensure the connector is fully seated onto the UV lamp.
4. Once the lamp is fully seated on the connector, slide the connector and bushing into the aluminum gland nut. Gently press down on the bushing and squeeze/slide the U clip through the gland nut's four upper holes (2 pair, 180° apart).
5. Plug in ballast to the electrical outlet. **RESET LAMP LIFE TIMER AFTER LAMP REPLACEMENT \*PAGE 15)**

## QUARTZ SLEEVE REPLACEMENT / CLEANING:

Mineral deposits and sediment may accumulate on the quartz sleeve decreasing the UV light transmittance and system performance. Good maintenance of filtration equipment will reduce the accumulation of residues. If necessary, remove the quartz sleeve and clean with a commercially available scale remover (CLR, Lime-Away, etc.) and a lint free cloth. Repeat the process as often as necessary to keep the quartz sleeve clean. Be sure to remove all traces of cleaning fluid from the sleeve before it is reinstalled in the UV chamber (be sure not to allow liquid inside the sleeve).

1. First remove the UV lamp by following steps 1 & 2 as outlined in the "Lamp Replacement" section above.
2. Shut off the upstream water supply that feeds water into the UV chamber.
3. Shut off the downstream water supply. Use the filter housing vent-valve to slowly depressurize. If your system does not have a separate downstream valve, simply open a downstream faucet to release any pressure that may be built-up in the system.

4. Remove the aluminum gland nut by turning counter clockwise. Place a small pail under the UV chamber to catch any water that may leak from the system. Grasp the quartz sleeve and fully remove from the UV chamber. Make sure the sealing o-ring is removed with the quartz sleeve. As with the lamp, make sure the sleeve is removed from the UV chamber being careful not to angle the sleeve as it is removed from the chamber to avoid breakage.
5. Clean the sleeve as previously described, or replace with a new sleeve. Reinstall the quartz sleeve in the reverse order. To install the sleeve, carefully insert the sleeve into the UV chamber (do not drop) until the sleeve domed end seats in the center of the hourglass retainer spring located in the end of the chamber. Install o-ring onto the sleeve until it is positioned against the chamfered seat. Make sure the small lamp compression spring is inside the sleeve.
6. Reinstall the aluminum gland nut on the UV chamber and tighten by turning clockwise. The gland nut should be **hand-tightened only**, the use of a wrench is not required, nor recommended. Reinstall the UV lamp and connector as outlined in steps three and four of the "Lamp Replacement" section.
7. Slowly turn on water and pressurize the chamber to verify that there are no leaks.
8. Reconnect to power source and ensure that the UV lamp is operating by verifying ballast green LED indicator is on and display is operational.

**Note:** After replacing the UV lamp or quartz sleeve, perform the disinfection procedure.

### FILTER CARTRIDGE REPLACEMENT :

It is recommended to change the filter cartridge every six months (or earlier). Please note that a drop in pressure may indicate that the filter cartridge requires replacement.

It is recommended to replace the filter housing sump at least every 5 years.

**Note:** Prior to performing any work on the drinking water system, **ALWAYS DISCONNECT THE ELECTRONIC BALLAST CONTROLLER FIRST**. As a small amount of water may leak from the cartridges during this procedure, please place a small bucket under the system to catch any water.

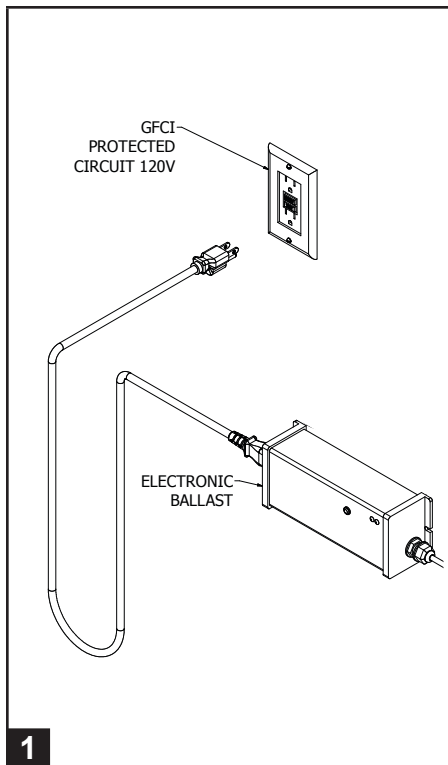

**1**

- Unplug the electronic ballast controller.

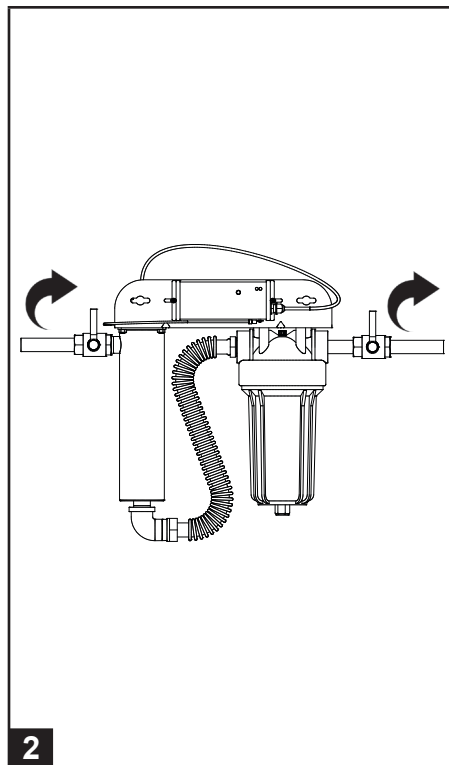

**2**

- Shut off water supply.

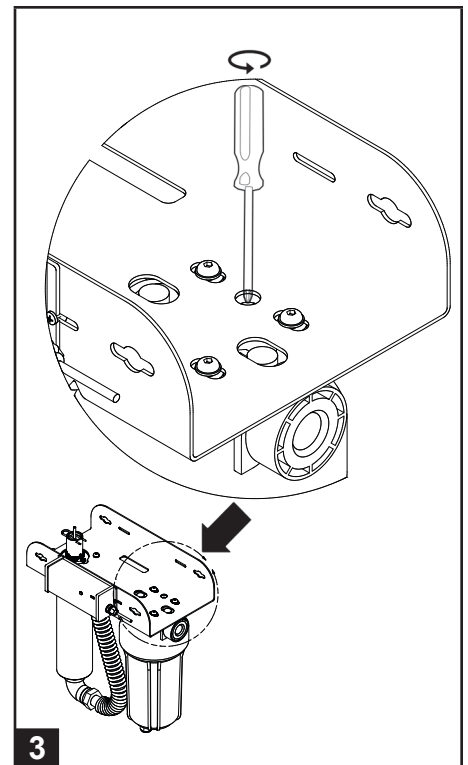

**3**

- Release the pressure from the filter using the vent-valve on top of the filter head.

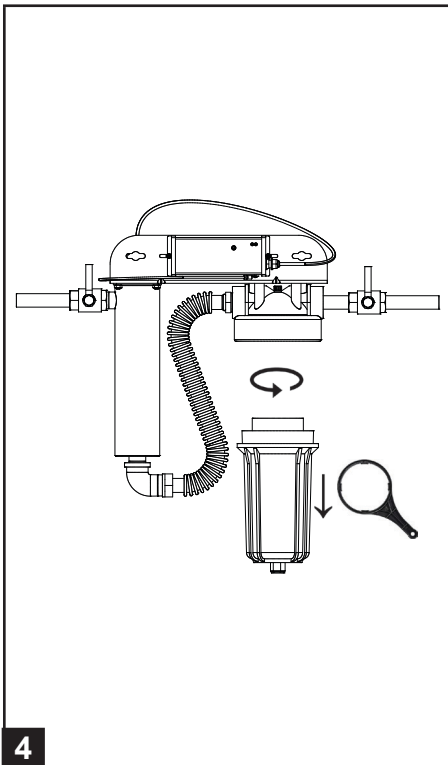

4

- Remove sump housing using the sump spanner wrench.

**Note:** Be careful as it will be full of water and heavy. Recommend a bucket or pail under the sump. If sump is fitted with a bottom drain port, removing the plug to drain the system into the bucket is recommended.

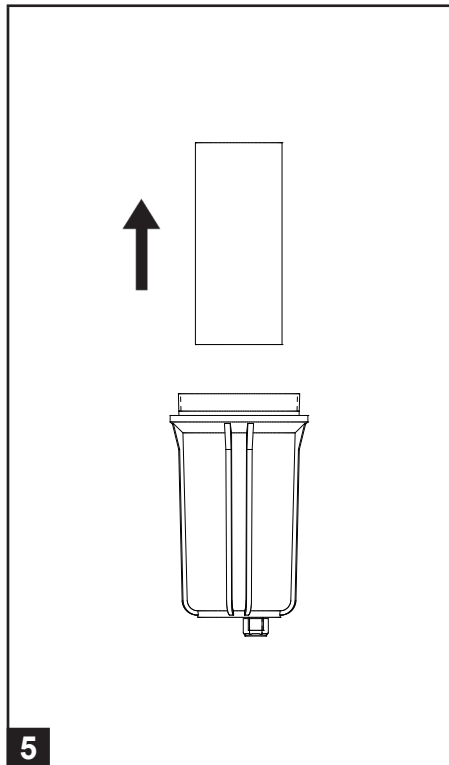

5

- Remove and discard the used filter cartridge in accordance with applicable codes and regulations. Wipe clean the sump housing with cold water and a soft sponge.
- Before installing new filter cartridge, make sure filter housing o-ring seal is properly seated and shows no sign of visible damage. Ensure o-ring is lubricated using silicone based lubricant.

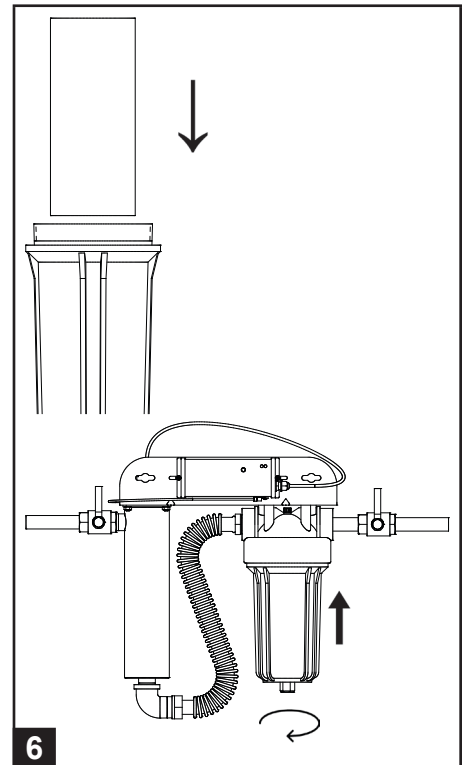

6

- Open the new filter cartridge wrap and discard wrap. Insert the new filter cartridge into the sump housing and connect to the unit using the sump spanner wrench.
- Note:** Be careful not to overtighten.

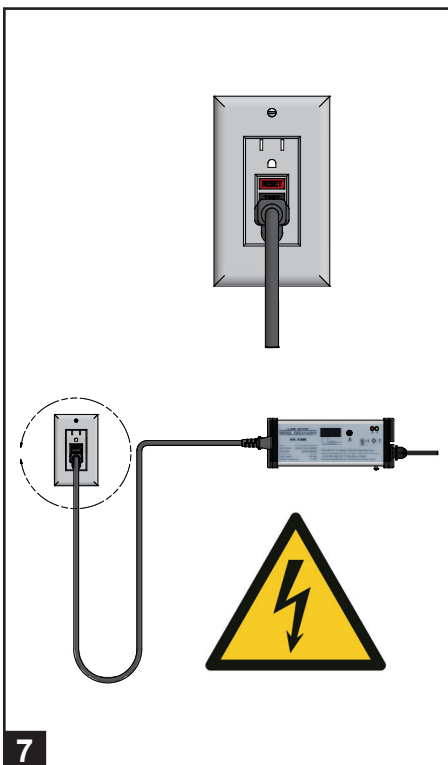

7

- Plug the electronic ballast controller into the GFCI outlet and power-up the system.

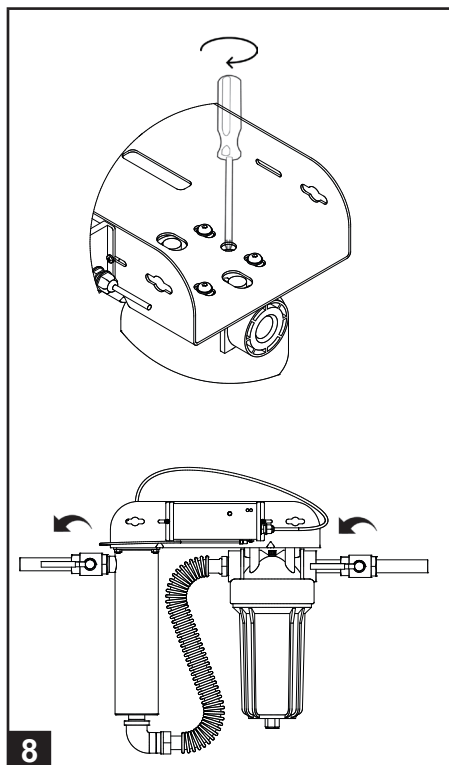

8

- Make sure vent-valve is closed.
- Slowly turn on water supply.

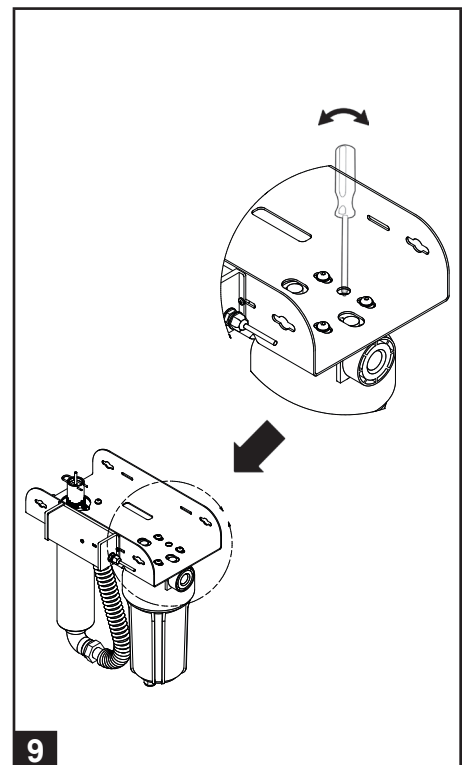

9

- Vent to purge air, then turn and tighten vent-valve closed.
- Let water flow for at least 5 minutes before use.

# ELECTRONIC BALLAST OPERATION:

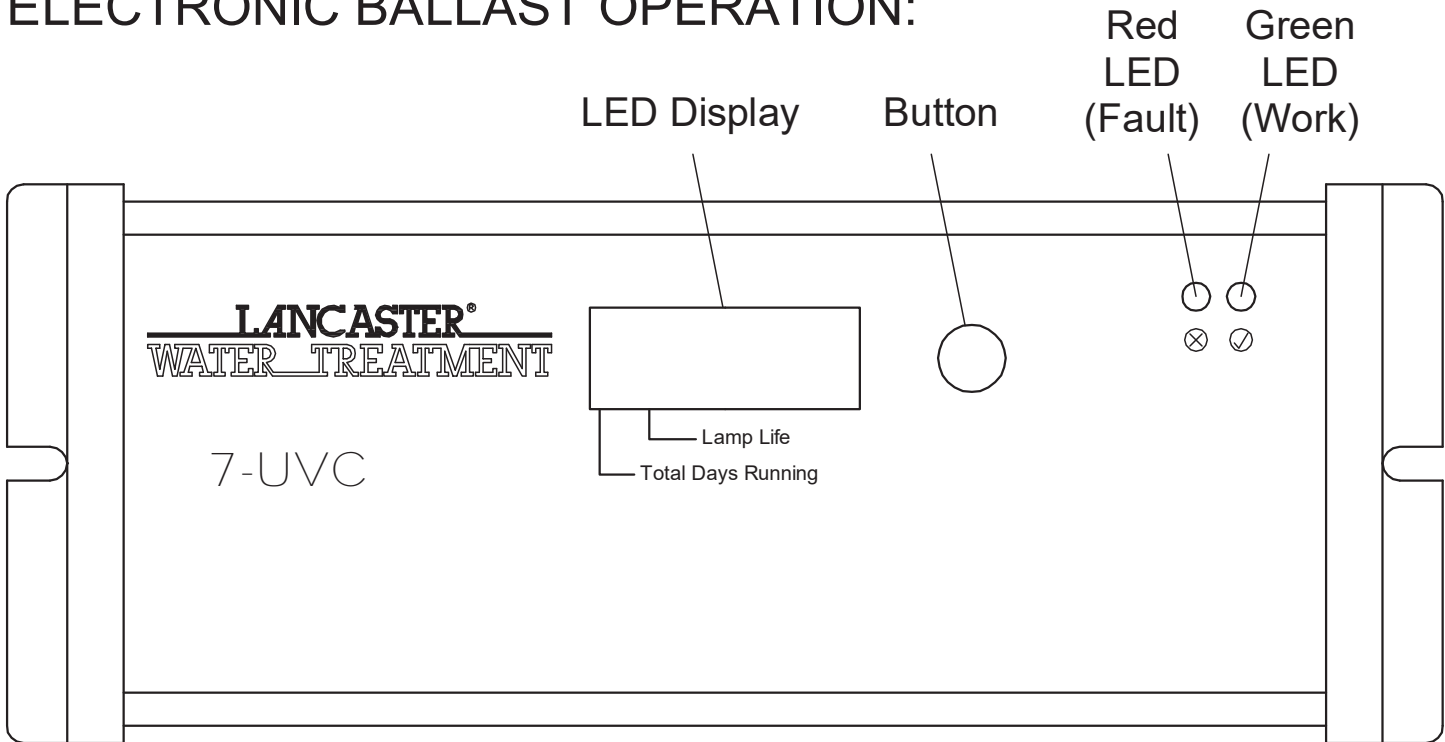

The 7-UVC Electronic Ballast (a.k.a. EPS-Electronic Power Supply or simply “controller”) is equipped with visible and audible operation indicators:

**LAMP-ON INDICATOR:** Steady “work” green LED.

**LAMP LIFE REMAINING (DAYS):** Default count down display (365 - 0); manually reset - see \* below.

**BALLAST TOTAL RUNNING DAYS:** Incremental display (0-9999); cannot be reset. To view, press and hold button for 2 seconds, release button and LED display will show ballast total days running. After 10 seconds, the LED display will automatically return to default display (lamp life) or shortly press and hold button again (2 seconds) before 10 seconds elapse to return to the default (lamp life) display.

**LAMP REPLACEMENT REMINDER:** The 365 day countdown timer displays the number of days remaining until lamp replacement is required. When the countdown timer reaches 0 days an audible alarm sounds (1 second BEEP every 5 seconds), the red LED flashes and the display will indicate alarm A3.

**LAMP REPLACEMENT REMINDER DELAY:** To allow time for obtaining a replacement lamp, the audible alarm can be silenced for 7 days by pressing and holding the button for 2-5 seconds. The display will continue to show A3 and the red LED will continue to flash. After 7 days, the audible alarm will sound again if the lamp has not been replaced. The alarm can be silenced up to 4 times (28 days). After 4 times, the alarm can no longer be silenced until a replacement lamp is installed and the lamp life timer is reset.

Please note that the lamp has an approximate life of one year. Although the lamp will continue to operate long past one year, the UV output continually decreases after one year and may no longer provide adequate disinfection. Use only Lancaster Water Treatment lamps to ensure proper operation and performance.

\* **RESET LAMP LIFE TIMER AFTER LAMP REPLACEMENT:** After replacing the lamp by following instructions on page 12, reset the lamp life timer to 365 days by pressing and holding the button for 10 seconds... LED displays “rSET”... keep holding button until LED displays 365 and alarm sounds (1 BEEP). Release button.

**LAMP FAILURE INDICATOR:** In the event of a failure of the lamp (no current running through the lamp), an audible alarm sounds (1 second BEEP every 1 second), the red LED flashes and the display continues to show lamp life remaining days but stops counting down (ballast total running days continues counting). The audible alarm cannot be silenced. Please note that if this condition occurs and you are on a non-municipal water source, you should immediately stop using the water for potable applications until the lamp is replaced and distribution lines are disinfected.

**BALLAST FAILURE INDICATOR:** Blank display.

## TROUBLESHOOTING GUIDE

Symptom	Possible Causes	Solutions
Pressure Drop	Sediment pre-filter clogged	<ul style="list-style-type: none"> <li>replace filter cartridge with appropriate 5 micron cartridge <b>Note:</b> check source water supply as fluctuations may occur in source pressure</li> </ul>
	Flow regulator (not provided)	<ul style="list-style-type: none"> <li>flow regulator will result in pressure drop when approaching full flow</li> </ul>
High Bacteria Counts	Quartz sleeve is stained or dirty	<ul style="list-style-type: none"> <li>clean sleeve with scale cleaner and eliminate source of staining problem (i.e. soften hard water, see page 3)</li> </ul>
	Change in feed water quality	<ul style="list-style-type: none"> <li>have source water tested to ensure that water quality is still within allowable limits for this system</li> </ul>
	Contamination in water lines after UV system due to a power failure, plumbing dead ends, etc.	<ul style="list-style-type: none"> <li>it is imperative that effluent water stream be shocked with chlorine (bleach) before water leaves UV system - disinfection system must have a bacterial free distribution system to work effectively (see page 10-11 disinfection procedure).</li> </ul>
	Possible break-through of sediment through pre-filter	<ul style="list-style-type: none"> <li>have source water tested for turbidity - may need stepped filtration in order to catch all sediment entering water system (20 micron filter followed by a 5 micron filter followed by UV system)</li> </ul>
Heated Product Water	Common problem caused by infrequent use of water; water sitting in UV chamber and heating up	<ul style="list-style-type: none"> <li>run water until it returns to ambient temperature</li> </ul>
Excessive Heat Generated	Water temperature is too high	<ul style="list-style-type: none"> <li>Ensure treatment is on cold water side only (prior to heating of water)</li> </ul>
Water Appears Milky	Caused by air in the water lines	<ul style="list-style-type: none"> <li>run water until air is purged</li> </ul>
UV Chamber Leaking Water	Problem with o-ring seal on gland nut	<ul style="list-style-type: none"> <li>ensure o-ring is in place, check for cuts or abrasions, clean o-ring, moisten with water and re-install, replace if necessary</li> </ul>
	Condensation on reactor chamber caused by excessive humidity & cold water	<ul style="list-style-type: none"> <li>check location of disinfection system and control humidity</li> </ul>
	Inadequate (misaligned or cross-threaded) inlet/outlet port connections	<ul style="list-style-type: none"> <li>check thread connections, reseal with Teflon® tape and re-tighten</li> </ul>
	Water hammer causing pressure spikes	<ul style="list-style-type: none"> <li>Install a "water hammer" arrestor in the plumbing system</li> </ul>
Leaks Between Filter Sump and Filter Head.	Sump not sufficiently tightened.	<ul style="list-style-type: none"> <li>Tighten further the sump with the wrench.</li> </ul>
	O-ring affected/old.	<ul style="list-style-type: none"> <li>If the sump still leaks, change the sump's O-ring with a new one (use original replacement / spare parts).</li> </ul>
Leaks in Filter Inlet / Outlet Connections.	Not enough sealant and/or connection not sufficiently tightened.	<ul style="list-style-type: none"> <li>Remove the previous sealing tape from the fitting and place more sealing tape and/or tighten the connection properly.</li> </ul>
System Shutting Down Intermittently	Interrupted power supply	<ul style="list-style-type: none"> <li>ensure system has been installed on its own circuit, as other equipment may be drawing power away from UV (i.e. pump or refrigerator)</li> <li>UV system should not be installed on a circuit which is incorporated into a light switch</li> </ul>
Lamp Failure Alarm on - New Lamp	Loose connection between lamp and connector	<ul style="list-style-type: none"> <li>disconnect lamp from connector and reconnect, ensuring that a tight fit is accomplished</li> </ul>
	Moisture build up in connector may keep lamp and connector from making a solid connection	<ul style="list-style-type: none"> <li>eliminate chance of any moisture getting to the connector and/or lamp pins</li> </ul>
LED Display reads "A3"	Lamp life expired - countdown is at "0" days	<ul style="list-style-type: none"> <li>Press and hold button 2 to 5 seconds for an alarm silence delay, replace lamp (see page 12 UV lamp replacement)</li> </ul>
LED Display is Blank	No power to electronic ballast; GFCI wall socket is tripped	<ul style="list-style-type: none"> <li>Reset, following GFCI manufacturer's instructions</li> <li>Check socket with other applications</li> </ul>

