

Series UMC Universal Manifold Check Assembly

(With or Without Control Valve)

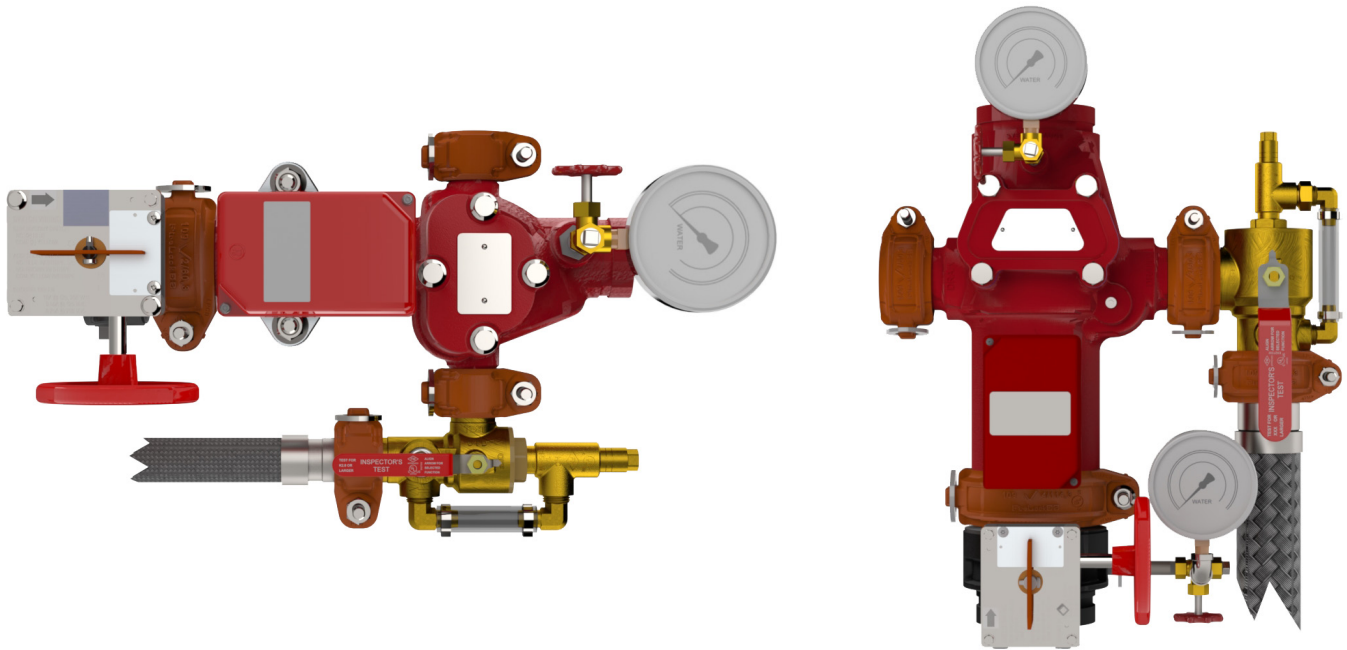

⚠ WARNING



- Read and understand all instructions before attempting to install any Victaulic products.
 - Always verify that the piping system has been completely depressurized and drained immediately prior to installation, removal, adjustment, or maintenance of any Victaulic products.
 - Confirm that any equipment, branch lines, or sections of piping that may have been isolated for/during testing or due to valve closures/positioning are identified, depressurized, and drained immediately prior to installation, removal, adjustment, or maintenance of any Victaulic products.
 - Wear safety glasses, hardhat, and foot protection.
- Failure to follow these instructions could result in death or serious personal injury and property damage.

- The Series UMC Universal Manifold Check Assembly shall be used only in fire protection systems that are designed and installed in accordance with current, applicable National Fire Protection Association (NFPA 13, 13D, 13R, etc.) standards, or equivalent standards, and in accordance with applicable building and fire codes. These standards and codes contain important information regarding protection of systems from freezing temperatures, corrosion, mechanical damage, etc.
- These installation instructions are intended for an experienced, trained installer. The installer shall understand the use of this product and why it was specified for the particular application.
- The installer shall understand common industry safety standards and potential consequences of improper product installation. Failure to follow installation requirements and local and national codes and standards could compromise system integrity or cause system failure, resulting in death or serious personal injury and property damage.

INTRODUCTION

The Series UMC Universal Manifold Check Assembly is a complete floor control valve assembly or shotgun riser assembly:

FLOOR CONTROL VALVE ASSEMBLY – The UMC meets NFPA 13 requirements for “Floor Control Valve Assemblies” where multi-story buildings require zoning by floor, or whenever separate control and floor zoning is specified. Per NFPA 13 requirements, a system pressure gauge is provided on the system side of the clapper. If specified, a supply-side gauge may be added to the provided ½-inch NPT port on the control valve.

SHOTGUN RISER ASSEMBLY – Shotgun riser assemblies are typically installed in vertical orientations on individual system risers. The 4 – 8-inch/ 114.3 – 219.1-mm sizes of the UMC are provided with a supply-side and system-side gauge. The supply-side gauge is located at the ½-inch NPT port on the control valve.

NOTICE

- NFPA 13 requires a test connection capable of providing a flow rate equal to or less than one sprinkler of the smallest orifice in the system.
- Drawings and/or pictures in this manual may be exaggerated for clarity.
- This product and this installation, maintenance, and testing manual contain trademarks, copyrights, and/or patented features that are the exclusive property of Victaulic.

ASSEMBLY DRAWINGS

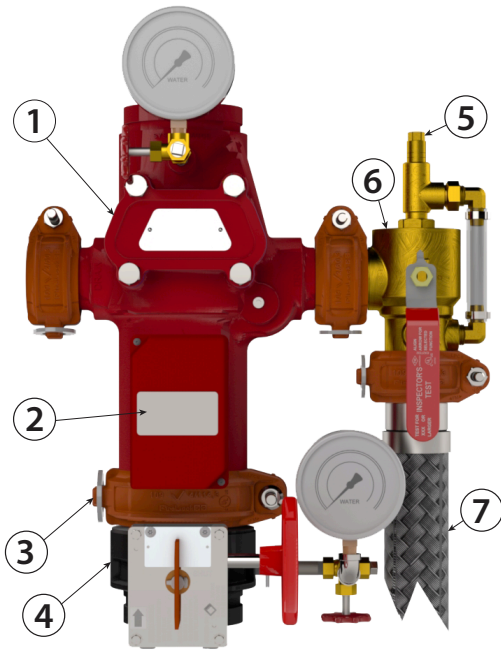

1 ¼ – 6-INCH/42.4 – 168.3-MM SIZES
(4-INCH/114.3-MM ASSEMBLY SHOWN ABOVE)

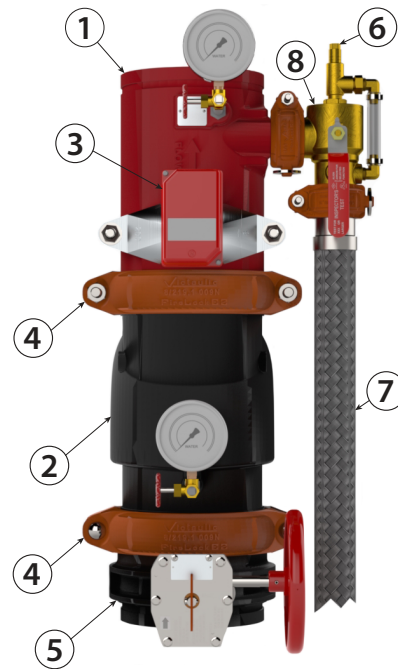

8-INCH/219.1-MM SIZE

Item	Description for 1 ¼ – 6-inch/42.4 – 168.3-mm Sizes
1	UMC Body with Removable Cover Plate*
2	Flow Switch
3	Rigid Coupling
4	Control Valve with Internal Supervisory Switch (Optional)†
5	Adjustable Pressure Relief Valve (ARV)**
6	Universal Test and Drain Assembly (UTD)‡
7	Stainless Steel Braided Flexible Drain Hose Assembly (Grooved x Grooved Connections)

Item	Description for 8-inch/219.1-mm Size
1	UM Body**
2	Check Valve
3	Flow Switch
4	Rigid Coupling
5	Control Valve with Internal Supervisory Switch (Optional)†
6	Adjustable Pressure Relief Valve (ARV)**
7	Stainless Steel Braided Flexible Drain Hose Assembly (Grooved x Grooved Connections)
8	Universal Test and Drain Assembly (UTD)‡

* UL Listed under File EX27312 Riser Manifold with Flow Detection with Check Valve

** UL Listed under File EX27312 Riser Manifold with Flow Detection

† The control valve for 1 ¼ – 1 ½-inch/42.4 – 48.3-mm sizes is the Victaulic Series 728 FireLock™ Ball Valve.

The control valve for 2 – 8-inch/60.3 – 219.1-mm sizes is the Victaulic Series 705 FireLock™ Butterfly Valve

*** NFPA 13 requirement that relief valve is UL Listed – Pre-piped to drain, preset for 175 psi/12 Bar, and adjustable to 310 psi/21 Bar for high-pressure system conditions and hydrostatic tests. NOTE: It is not necessary to remove the Adjustable Pressure Relief Valve (ARV) to perform a hydrostatic test. The ARV may be adjusted temporarily to a pressure above the test pressure.

‡ For flow testing, the 1-inch/33.7-mm Universal Test and Drain Assembly (UTD) utilizes a K2.8 test orifice; the 1 ¼-inch/42.4-mm UTD utilizes a K4.2 test orifice; and the 2-inch/60.3-mm UTD utilizes a K5.6 test orifice. Operating positions for the UTD are: Off (normal operating condition), Drain (full drain), and Test (flow through K-factor orifice).

LEFT-HANDED VERSUS RIGHT-HANDED ORIENTATIONS

Both the shotgun riser assembly and the floor control valve assembly are available as left- or right-handed orientations. While looking at the faceplate with the UMC in the vertical position and flow upward (shotgun riser), the position of the UTD determines the orientation of the valve.

NOTICE

- The 8-inch/219.1-mm version is available only in the right-hand orientation.
- Field relocation of the UTD to the opposing “mirrored port” is allowed and does not affect UMC Listings and Approvals.

LEFT-HANDED ORIENTATION

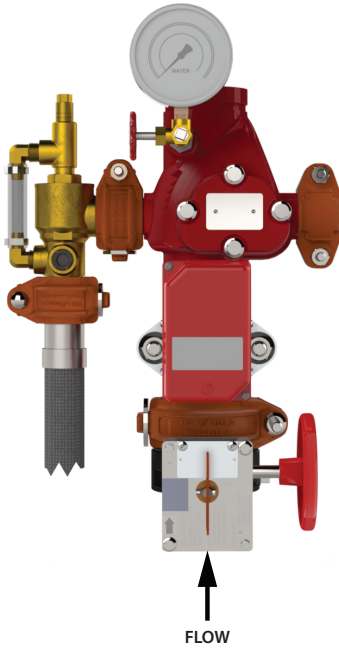

RIGHT-HANDED ORIENTATION

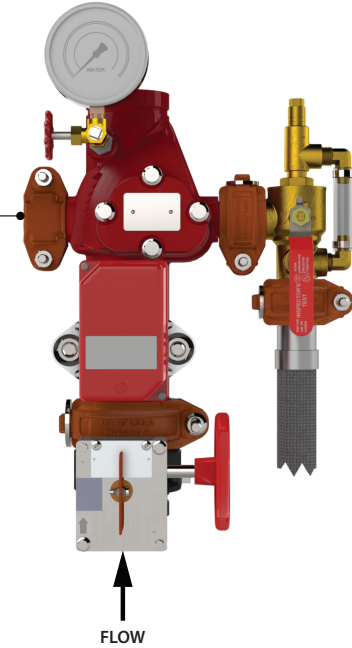

Mirrored Port for Alternate UTD Location or Sprinkler Outlet

LEFT-HANDED ORIENTATION

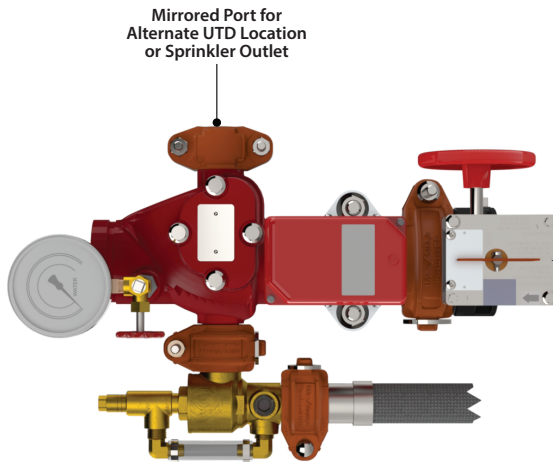

Mirrored Port for Alternate UTD Location or Sprinkler Outlet

RIGHT-HANDED ORIENTATION

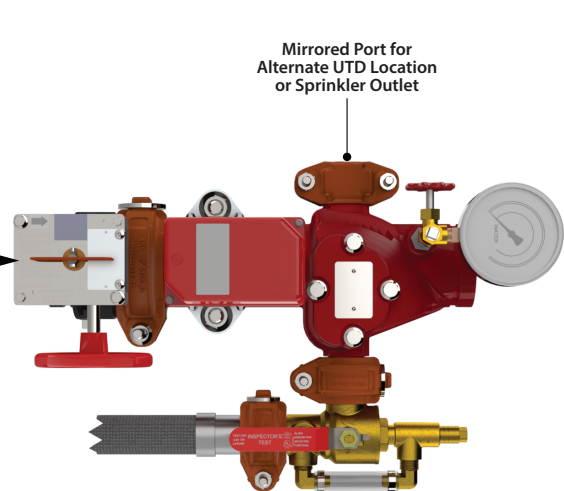

Mirrored Port for Alternate UTD Location or Sprinkler Outlet

REPRESENTATIVE OF 1¼ - 6-INCH/42.4 - 168.3-MM SIZES
(3-INCH/88.9-MM SIZE SHOWN)

NOTES:

- The control valve for 1¼ – 1½-inch/42.4 – 48.3-mm sizes is the Victaulic Series 728 FireLock™ Ball Valve.
- The control valve for 2 – 6-inch/60.3 – 168.3-mm sizes is the Victaulic Series 705 FireLock™ Butterfly Valve.
- The mirrored port for 2½ – 3-inch/73.0 – 88.9-mm sizes contains a Style 115 Reducing Coupling (1¼-inch/42.4-mm OGS x 1-inch/33.7-mm IGS).

INSTALLATION

- The UMC is shipped preassembled in a single box. Confirm that adequate space is available for the assembly.
- Flush water supply piping. Before installing the UMC, flush the water supply piping thoroughly to remove all foreign material.
- The UMC shall be installed in accordance with all applicable installation standards (i.e. NFPA 13 or other).
- Protect system from freezing temperatures. The UMC and supply piping SHALL NOT be located in an area where exposure to freezing temperatures or mechanical damage may occur. Install the UMC in an accessible and visible location that is maintained at or above a minimum temperature of 40°F/4°C.
- Confirm material compatibility. It is the system designer's responsibility to confirm material compatibility of the UMC and associated accessories when a corrosive environment or contaminated water is present.
- The UMC may be installed in the horizontal or vertical (flow upward) orientation.
- All electrical connections shall be made per the applicable installation standard and/or the National Electric Code (i.e. NFPA 70, NFPA 72 or other).
- Verify that the braided flexible drain hose does not become kinked or permanently deformed when routing it to the drain connection. The flexible braided drain hose is intended for use only downstream of a drain valve and shall not be used anywhere else within the system.
- All coupling connections shall be made by referencing the current version of the installation instructions, which can be downloaded by scanning the QR codes below. All coupling connections shall be checked to verify proper installation, in accordance with the following instructions.



I-009N Installation Instructions

For connections to the control valve on certain UMC sizes
For connections to the drain hoses on 2½ inch/73.0 mm and larger UMC sizes



I-108 Installation Instructions

For connections to the drain hose on certain UMC sizes



I-109 Installation Instructions

For connection to the control valve on certain UMC sizes
For connections to the drain hose on certain UMC sizes



I-115 Installation Instructions

For the mirrored port connection of 2½ – 3-inch/73.0 – 88.9-mm sizes

- Per NFPA 13, proper hydrostatic test procedures shall be followed. **NOTE: It is not necessary to remove the ARV to perform a hydrostatic test. The ARV may be adjusted temporarily to a pressure above the test pressure. Verify that the ARV is returned to its normal setting after completing the hydrostatic test.**

FLOW SWITCH WIRING

The flow switch includes two sets of switches. One set can be used to activate the central fire alarm system, while the other set can be used to activate a local alarm, if necessary. Refer to the schematic below for the wiring diagram.

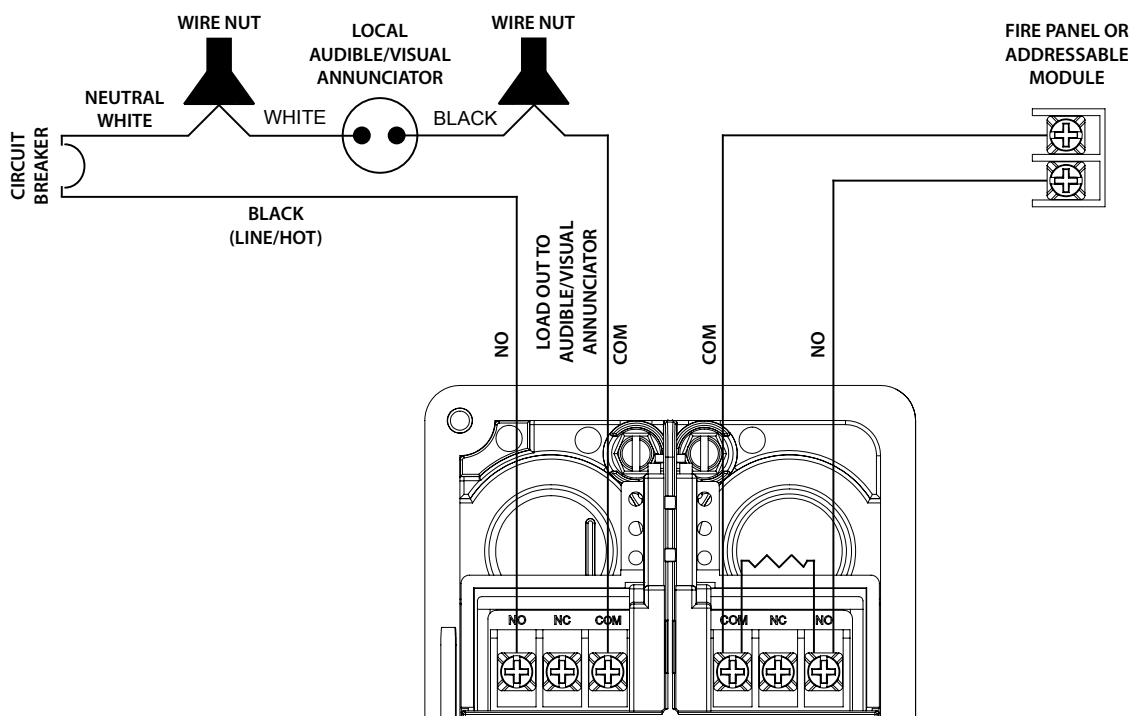

CONTROL VALVE WIRING

The following wiring instructions apply to both the Victaulic Series 728 FireLock™ Ball Valve and Victaulic Series 705 FireLock™ Butterfly Valve.



Scan QR code for access to the Series 728 Installation and Wiring Instructions



Scan QR code for access to the Series 705 Installation and Wiring Instructions

- The supervisory switch contains two single-pole, double-throw, prewired switches.
- Switches are rated:
 - 10 amps @ 125 or 250 VAC/60 Hz
 - 0.50 amps @ 125 VDC
 - 0.25 amps @ 250 VDC
- Switches supervise the control valve in the “fully opened” position. Switches will not supervise the valve in the “closed” position.**
- One switch contains two #18 insulated wires per terminal, which permit complete supervision of leads (refer to diagrams and notes below). The second switch contains one #18 insulated wire per terminal. This double circuit provides flexibility to operate two electrical devices at separate locations, such as an indicating light and an audible alarm, in the area that the control valve is installed.
- A #14 insulated ground lead (green) is provided.
 - Switch #1 = S1 For connection to the supervisory circuit of a UL Listed alarm control panel
 - Switch #2 = S2 Auxiliary switch that may be connected to auxiliary devices, per the authority having jurisdiction

- S1** {
- Normally Closed Contact: (2) Blue
 - Switch is Open When Valve is in “Fully Opened” Position
 - Common Contact: (2) Yellow
- S2** {
- Normally Closed Contact: Blue with Orange Stripe
 - Normally Open Contact: Brown with Orange Stripe
 - Common Contact: Yellow with Orange Stripe

Only S1 (two leads per terminal) may be connected to the fire alarm control panel.

Connection of alarm switch wiring shall be in accordance with NFPA 72, and the auxiliary switch per NFPA 70 (NEC).

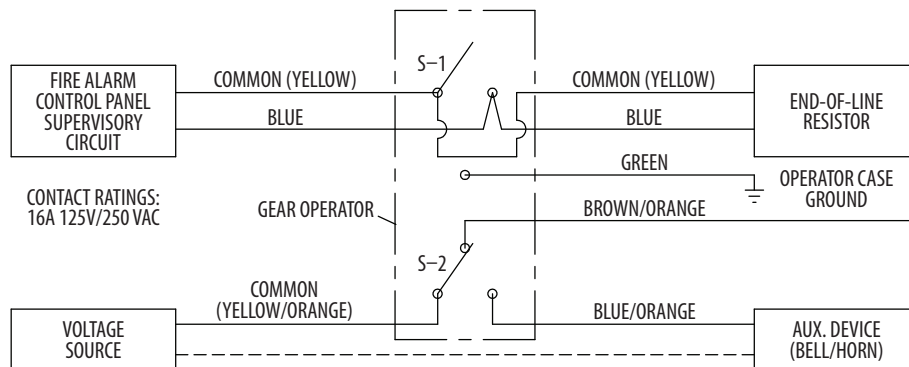

VALVE WIRING SHOWN WITH VALVE IN OPEN POSITION

ARV SETTING PROCEDURE

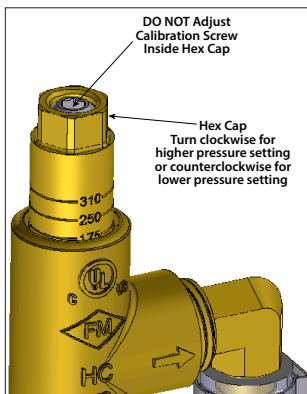

- The 300-psi/21-Bar ARV is factory set to relieve at approximately 175 psi/12 Bar.
- The ARV may be reset to a higher pressure; however, it shall be reset to relieve at a pressure that is in accordance with requirements of the local authority having jurisdiction (typically nominal 10 psi/0.7 Bar above the expected normal system pressure).
- To reset the ARV, use an adjustable crescent wrench to turn the hex cap clockwise for a higher pressure setting or counterclockwise for a lower pressure setting. Use the calibrated lines on the stem for an approximate relief pressure setting. One full turn of the hex cap will result in approximately 25 psi/1.7 Bar increase or decrease.
- DO NOT adjust the calibration screw inside the hex cap, as indicated in the drawing to the left.
- To verify the new setting, isolate the ARV and use a small hydrostatic pump attached to the supply. Increase the pressure to 10 psi/0.7 Bar above the expected normal system pressure. Readjust the ARV, as needed, to maintain a 10 psi/0.7 Bar higher relief setting.

NOTE: An ARV replacement kit is available for order. This kit includes the ARV, a hose, and two worm gear hose clamps.

TESTING



Refer to NFPA 25, FM Datasheets, or any applicable local requirements to perform testing. The authority having jurisdiction in the area may require these tests on a more frequent basis. Verify these requirements by contacting the authority having jurisdiction in the affected area.

Before proceeding with any tests involving water flow, the following precautions shall be taken.

NOTE: It is not necessary to remove the ARV to perform a hydrostatic test. The ARV may be adjusted temporarily to a pressure above the test pressure. Verify that the ARV is returned to its normal setting after completing the hydrostatic test.

1. Check for alarm connections to a central station or fire department. If such connections are found, notify the authority having jurisdiction, remote station alarm monitors, and those in the affected area before proceeding with testing. **NOTE:** A main drain test may also operate local fire alarms, unless they are temporarily disabled.
2. Check the location where the test connection discharges to verify that all is clear and that there is no possibility of water flow causing property damage or personal injury.
3. Check the end of the test connection to verify that it is unobstructed. To achieve a satisfactory test, there shall be an unrestricted flow of water when the handle on the UTD is in the "DRAIN" (full drain) position.
4. Move the handle on the UTD to the "TEST" (flow through K-factor orifice) position. Verify that an alarm condition results within the timeframe specified by the local authority having jurisdiction.
5. Move the handle on the UTD to the "OFF" (normal operating) position. **NOTE:** The ARV is located on the upstream side of the UTD and will continue to vent excess system pressure with the handle on the UTD in the "OFF" (normal operating) position.

REQUIRED INSPECTIONS AND/OR MAINTENANCE

 WARNING	
	<ul style="list-style-type: none"> • Depressurize and drain the piping system before attempting to remove the cover plate from the UMC body. • The building owner or their representative is responsible for maintaining the fire protection system in proper operating condition. • To ensure proper system operation, refer to NFPA 25, FM Datasheets, or any applicable local requirements for valve inspection requirements. The authority having jurisdiction in the area may require these inspections on a more frequent basis. Verify these requirements by contacting the authority having jurisdiction in the affected area, and always refer to the instructions in this manual for additional inspection and testing requirements.
	<ul style="list-style-type: none"> • The frequency of inspections shall be increased in the presence of contaminated water supplies, corrosive/scaling water supplies, and corrosive atmospheres. • Any activities that require taking the valve out of service may eliminate the fire protection provided. A fire patrol is strongly recommended for the affected areas. • Before servicing or testing the system, notify the authority having jurisdiction. <p>Failure to follow these instructions could cause system failure, resulting in death or serious personal injury and property damage.</p>

Refer to NFPA 25, FM Datasheets, or any applicable local requirements to perform inspections and/or maintenance. The authority having jurisdiction in the area may require inspections and/or maintenance on a more frequent basis. Verify these requirements by contacting the authority having jurisdiction in the affected area.

1. Notify the authority having jurisdiction, remote station alarm monitors, and those in the affected area before performing any inspections, testing, or maintenance that requires closing the control valve.
2. Verify that the system is completely depressurized and drained immediately prior to removing the cover plate. Follow steps 2 - 5 of the "Clapper Removal and Replacement" section on the following page to remove the cover plate. **NOTE:** Keep the handle on the UTD in the "DRAIN" (full drain) position during any maintenance.
3. The water supply shall be free from sediment or other debris. During an inspection of a water control valve, if sediment or other debris is noted, a further examination of internal valve parts is required. Remove all deposits from all operating components and ports.

 CAUTION	
<ul style="list-style-type: none"> • DO NOT use solvents or abrasives on the clapper facing or near the seat ring. <p>Failure to follow this instruction could prevent the clapper from sealing, resulting in valve leakage.</p>	

Clapper Facing for 6-inch/168.3-mm and Smaller UMC Sizes: The clapper facing shall be checked for damage or wear. Wipe away any contaminants, dirt, and mineral deposits. **DO NOT USE SOLVENTS OR ABRASIVES.** Compounds that could damage the clapper facing shall never be used. If any damage or wear is present (i.e. foreign material embedded in the surface or cuts/tears), the clapper shall be replaced by following all steps in the "Clapper Removal and Replacement" section on the following page.

Seat Ring for 6-inch/168.3-mm and Smaller UMC Sizes: Wipe away any contaminants, dirt, and mineral deposits from the seat ring. **DO NOT USE SOLVENTS OR ABRASIVES.** If the seat ring contains any damage (nicks, embedded particles, etc.), the entire UMC assembly shall be replaced.

Flow Switch (All Sizes):

Periodic testing and inspection is required for the flow switch. Scan the applicable QR code provided for complete flow switch and paddle replacement instructions.



Scan QR code for flow switch used on 4-inch/114.3-mm and 6-inch/168.3-mm UMC sizes



Scan QR code for flow switch used on all other UMC sizes

ARV (All Sizes): The ARV is not field serviceable. If leakage is observed, test the pressure setting by referring to the “ARV Setting Procedure.” The ARV shall be replaced if it does not respond to field adjustments. **NOTE:** Visual calibration lines on the ARV are used for approximate adjustment. Verify the pressure setting with a calibrated pressure gauge.

UTD (All Sizes): The UTD does not require any regularly scheduled maintenance and is not field serviceable.

REPLACEMENT KIT INSTRUCTIONS

Full Clapper Replacement Kit for 6-inch/168.3-mm and Smaller Sizes

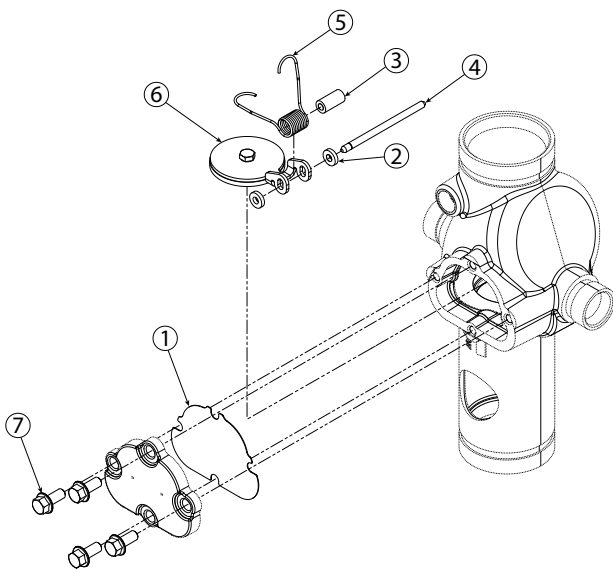

3-inch/88.9-mm Size Shown

Contents of Kit

Item	Description
1	Gasket
2	Clapper Spacers
3	Torsion Spring Spacer
4	Hinge Pin

Item	Description
5	Torsion Spring
6	Clapper Assembly
7	Hex Flange Screws

1. Notify the authority having jurisdiction, remote station alarm monitors, and those in the affected area before performing any maintenance that requires closing the control valve. Refer to the warning on the previous page.
2. Close the control valve.
3. Move the handle on the UTD to the “DRAIN” (full drain) position to fully drain the system.
4. For horizontal installations, after all pressure is released from the system, move the handle on the UTD to the “OFF” (normal operating position) or cover the drain port to prevent clapper assembly components from dropping into the drain piping.
5. Loosen the hex flange screws on the cover plate slowly. **NOTE:** DO NOT remove any hex flange screws until all are loosened.
6. Remove all hex flange screws, along with the cover plate and gasket.
7. Carefully grab the end of the hinge pin with pliers or a similar tool and pull it out from the body. **NOTE:** Support the clapper spacers, torsion spring, and torsion spring spacer while removing the hinge pin from the body. The torsion spring is under tension around hinge pin.
- 7a. If it is difficult to remove the hinge pin from the front of the body, remove the hinge pin plug from the back of the body. Use a hex key wrench or similar tool to push the hinge pin from the back of the body towards the front.
8. Carefully remove the old clapper assembly from the body.
9. Install the new kit components (Items 2 – 6), as shown in the drawing to the left. During replacement of the new clapper assembly, verify that the new torsion spring and new torsion spring spacer have been positioned properly around the new hinge pin so that the torsion spring applies tension to the clapper assembly. **Refer to the clapper spring orientation shown in the drawing to the left.**

10. If the hinge pin plug was removed in step 8, reinstall it into the back of the body.

11. Align the cover plate and new gasket to the body. Tighten the new hex flange screws into the cover plate/body in an even, crossing pattern to:

- 40 ft-lbs/54 N•m for 3-inch/88.9-mm and smaller sizes
- 20 ft-lbs/27 N•m for 4-inch/114.3-mm and larger sizes

DO NOT over-tighten the cover plate bolts.

CAUTION

- **DO NOT over-tighten the cover plate bolts.**

Failure to follow this instruction could cause damage to the cover plate gasket, resulting in valve leakage.

Refer to following page for additional replacement kit information.

Series UMC Universal Manifold Check Assembly

(With or Without Control Valve)

REPLACEMENT KIT INSTRUCTIONS (CONTINUED)

Clapper Seal Replacement Kit for 6-inch/168.3-mm and Smaller Sizes

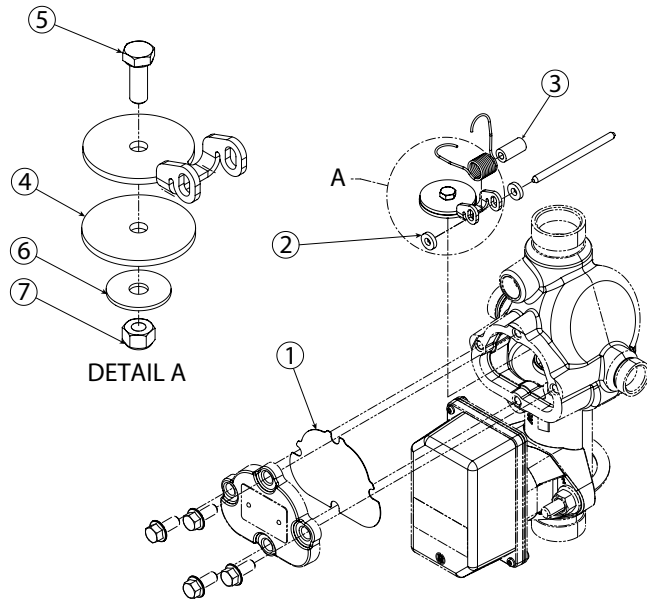

1½-inch/48.3-mm Size Shown

Contents of Kit

Item	Description	Item	Description
1	Gasket	5	Self-Sealing Hex Cap Screw
2	Clapper Spacers	6*	Washer
3	Torsion Spring Spacer	7*	Lock Nut
4	Clapper Facing		

* Not included with kit for 6-inch/168.3-mm valve size

1. Notify the authority having jurisdiction, remote station alarm monitors, and those in the affected area before performing any maintenance that requires closing the control valve. Refer to the warning on the previous page.
2. Close the control valve.
3. Move the handle on the UTD to the "DRAIN" (full drain) position to fully drain the system.
4. For horizontal installations, after all pressure is released from the system, move the handle on the UTD to the "OFF" (normal operating position) or cover the drain port to prevent clapper assembly components from dropping into the drain piping.
5. Loosen the hex flange screws on the cover plate slowly. **NOTE:** DO NOT remove any hex flange screws until all are loosened.
6. Remove all hex flange screws, along with the cover plate and gasket.
7. Carefully grab the end of the hinge pin with pliers or a similar tool and pull it out from the body. **NOTE:** Support the clapper spacers, torsion spring, and torsion spring spacer while removing the hinge pin from the body. The torsion spring is under tension around hinge pin.
- 7a. If it is difficult to remove the hinge pin from the front of the body, remove the hinge pin plug from the back of the body. Use a hex key wrench or similar tool to push the hinge pin from the back of the body towards the front.
8. Carefully remove the clapper assembly from the body.
9. Remove the old lock nut, self-sealing hex cap screw, washer, and clapper facing from the current clapper.
10. Install the new clapper facing, washer, self-sealing hex cap screw, and lock nut (Items 4 – 7) onto the current clapper, as shown in the drawing to the left.
11. Install the rebuilt clapper assembly, as shown in the drawing to the left. During replacement of the rebuilt clapper assembly, verify that the current torsion spring and new torsion spring spacer have been positioned properly around the current hinge pin so that the torsion spring applies tension to the clapper assembly. **Refer to the clapper spring orientation shown in the drawing to the left.**

12. If the hinge pin plug was removed in step 8, reinstall it into the back of the body.

13. Align the cover plate and new gasket to the body. Tighten the new hex flange screws into the cover plate/body in an even, crossing pattern to:

- 40 ft-lbs/54 N•m for 3-inch/88.9-mm and smaller sizes
- 20 ft-lbs/27 N•m for 4-inch/114.3-mm and larger sizes

DO NOT over-tighten the cover plate bolts.

CAUTION

- DO NOT over-tighten the cover plate bolts.

Failure to follow this instruction could cause damage to the cover plate gasket, resulting in valve leakage.

Check Valve Replacement Kit for the 8-inch/219.1-mm Size

Contact Victaulic regarding check valve replacement parts for the 8-inch/219.1-mm size of the UMC.

For complete contact information, visit victaulic.com

I-UMC 15304 REV B UPDATED 05/2021 Z000UMC000

VICTAULIC AND FIRELOCK ARE REGISTERED TRADEMARKS OR TRADEMARKS OF VICTAULIC COMPANY AND/OR ITS AFFILIATED ENTITIES IN THE UNITED STATES AND/OR OTHER COUNTRIES. © 2021 VICTAULIC COMPANY. ALL RIGHTS RESERVED.

