

### PRODUCT SPECIFICATIONS

WaterSentry Plus High Capacity Replacement Filter. Overall dimensions are 3-1/8" x 3-1/8" x 9-1/2".

<b>Dimensions:</b>	3-1/8" x 3-1/8" x 9-1/2"
<b>Shipping Weight:</b>	2 lbs.
<b>Flow Rate:</b>	1.5 GPM (5.6 L/m)
<b>Capacity:</b>	
<b>Temperature:</b>	40-100°F (4-38°C)
<b>Initial Pressure Drop:</b>	2-5 PSI (14-34 kPa)
<b>Maximum Pressure:</b>	105 PSI (724 kPa)
<b>Minimum Pressure:</b>	20 PSI (138 kPa)
<b>Water Inlet:</b>	3/8" (9.5mm) O.D. tube
<b>Water Outlet:</b>	1/4" (6.4mm) O.D. tube

**Special Note:** Compatible with Enhanced ezH2O Bottle Filling Stations

- Replacement filter for Elkay enhanced ezH2O bottle filling stations.
- Largest capacity filter reduces filter changes and maintenance costs for healthy hydration without the hassle.
- Designed for use in highly trafficked areas; filter should be replaced every 6,000 gallons or 1 year after installation.
- Equipped with quick-disconnect, ¼-turn installation, as well as automatic inlet shut-off valve that closes when filter is removed.
- Designed to reduce lead, cyst, particles and chlorine. Also reduces odors from incoming water.
- Spun Polypropylene prefilter mesh to prevent large, coarse sediment and particles from entering and clogging filter media.
- Filter is certified to NSF 42 and 53 for lead, cyst, particulate class 1, chlorine, taste and odor reduction.



#### A Century of Tradition and Quality.

For more than 100 years, Elkay has been making innovative products and providing exceptional customer care. We take pride in offering plumbing products that make life easier, inspire change and leave the world a better place.



**Product Compliance:** NSF 42  
NSF 53  
NSF 372 (lead free)



Drains are listed by IAPMO<sup>®</sup> as meeting the applicable requirements of the Uniform Plumbing Code<sup>®</sup>, International Plumbing Code<sup>®</sup>, and National Plumbing Code of Canada.

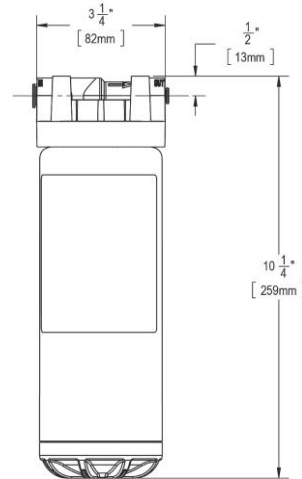
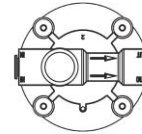

PART: \_\_\_\_\_ QTY: \_\_\_\_\_

PROJECT: \_\_\_\_\_

CONTACT: \_\_\_\_\_

DATE: \_\_\_\_\_

NOTES: \_\_\_\_\_

APPROVAL: \_\_\_\_\_

*In keeping with our policy of continuing product improvement, Elkay reserves the right to change product specifications without notice. Please visit [elkay.com](http://elkay.com) for the most current version of Elkay product specification sheets. This specification describes an Elkay product with design, quality, and functional benefits to the user. When making a comparison of other producers' offerings, be certain these features are not overlooked.*