



## Endeavor™ Line Achiever® Series iR Packaged Heat Pump



### RHP(A/X)ZR

Nominal Sizes: 2 to 5 Tons [7.03 to 17.6 kW]

Cooling Efficiency: 13.4 SEER2



## Table of Contents

Features & Benefits .....	3-4
Model Number Identification .....	5
General Data.....	6-7
General Data Notes .....	8
Gross Systems Performance Data .....	9-14
Indoor Airflow Performance.....	15-18
Electrical Data.....	19
Electric Heater Kits.....	20-21
Dimensional Data.....	22-25
Typical Installations .....	26
Accessories .....	27-38
Limited Warranty.....	40

## Features and Benefits

- **Scroll Compressor:** For maximum efficiency and quiet operation
- **Louvered Condenser Compartment:** (2) Protects the coil against yard hazards
- **One-piece Top with Drip Flange:** (3) Helps to keep water out of the unit
- **Supply and Return Air Openings:** (4) Feature a one-inch tall flange to prevent water migration into the ductwork
- **Access Panels:** (5) Easily removable and provides access to necessary components for serviceability
- **Side and Down Discharge Options:** Available on all models (Shipped horizontal flow standard)
- **Easily Accessible Blower Section:** (7) Features a slide-out blower
- **Conveniently Located Refrigerant Connections:** (8) For easy service diagnostics. Low pressure/loss of charge protection is standard on all models
- **Evaporator Coils:** MicroChannel evaporator coil delivers superior performance with less refrigerant charge and less weight than conventional copper tube/aluminum fin coils
- **Condenser Coils:** (9) "A" cabinet condenser coil features enhanced fins for better heat transfer and rifled copper tubing for greater efficiency. "X" cabinet condenser coil uses the latest microchannel technology for the most effective method of heat transfer.
- **Supplemental Electric Heat Strips:** (10) Up to 15 kW are available (field or factory installed) for periods of extreme cold temperatures. Single point wiring simplifies installation
- **Easily Accessible Control Box:** (12)
- **Thermal Expansion Valve:** (13) Is standard on all models and provides superior superheat control, reliability, and energy efficiency at all operating conditions
- **Filter Drier:** Is standard on all models
- **Rugged baserail:** (15) Included for improved installation and handling
- **Reversing Valve Directs Flow of Refrigerant:** And reverses the refrigerant flow when heating is required

## Package Heat Pump Features:

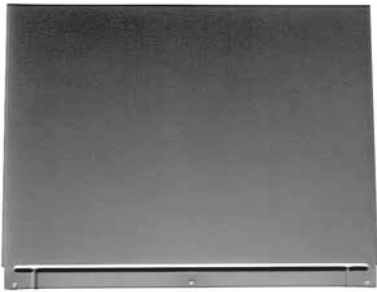

5

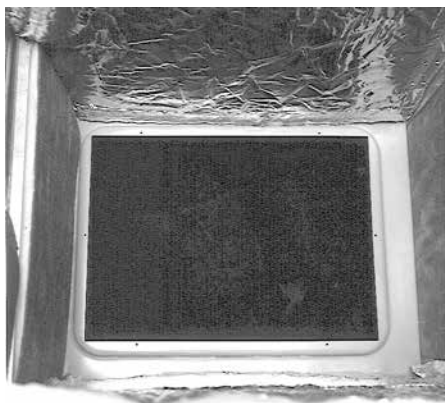
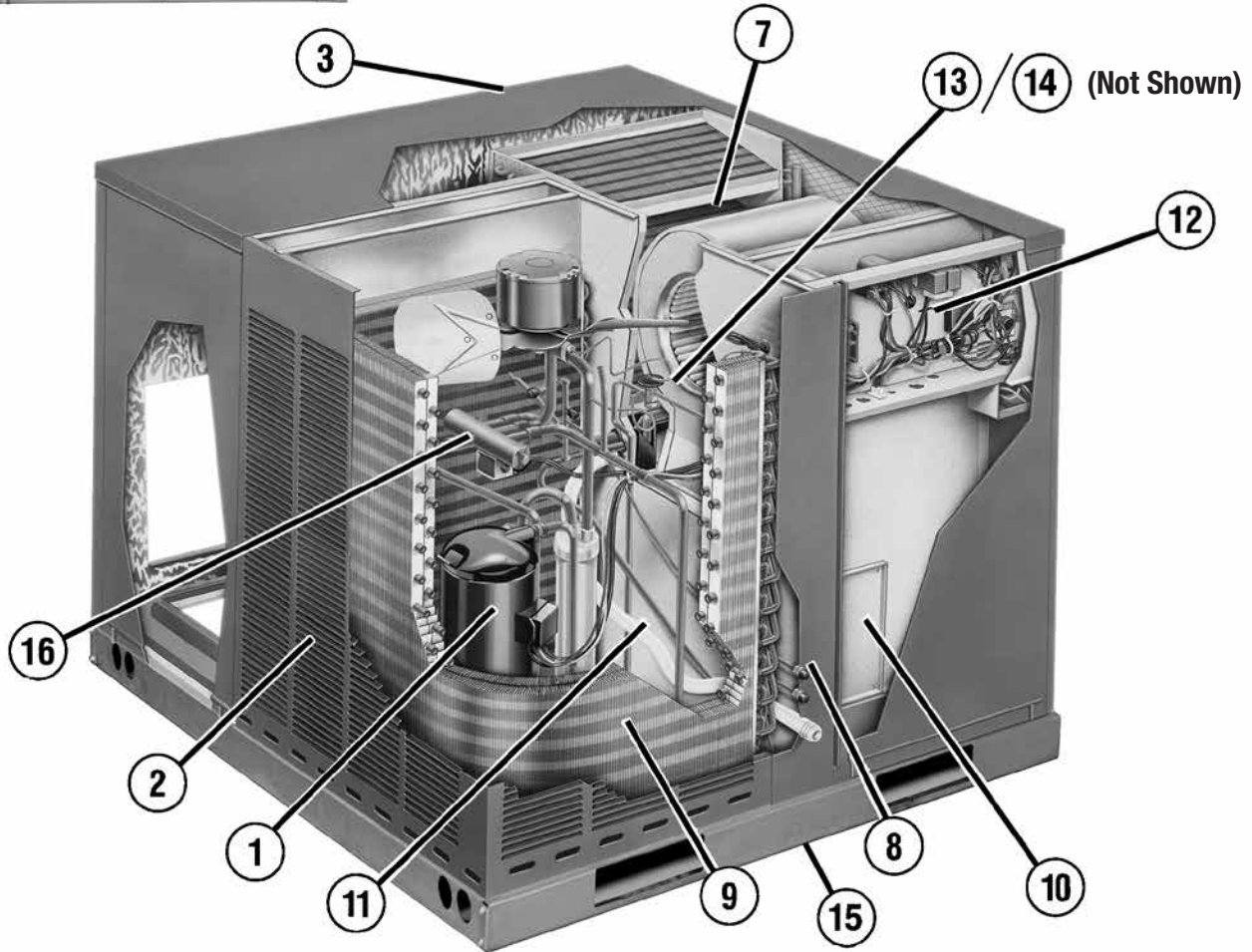
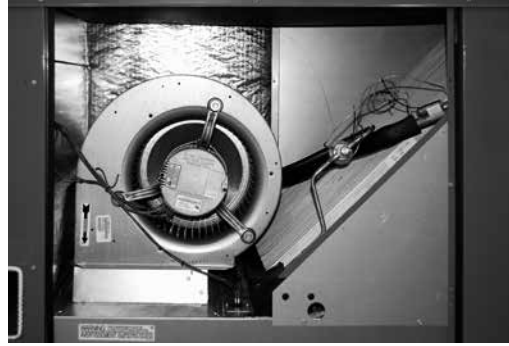

4

## Packaged Heat Pumps

<u>R</u>	<u>HP</u>	<u>A</u>	<u>Z</u>	<u>R</u>	<u>024</u>	<u>A</u>	<u>J</u>	<u>T</u>	<u>000</u>	<u>N</u>	<u>A</u>
Brand	Product Category	Platform	Refrigerant	Tier	Capacity BTU/HR	Major Series	Voltage	Drive	Electric Heat	Control	Minor Series
R - Ruud	HP - Heat Pump	A/X- ResiPack Convertible	Z - R410A	R - Base Tier (13.4 SEER2)	024 - 24,000 [7.03 kW] 030 - 30,000 [8.79 kW] 036 - 36,000 [10.55 kW] 042 - 42,000 [12.31 kW] 048 - 48,000 [14.07 kW] 060 - 60,000 [17.58 kW]	A - 1st Design	J - 1ph, 208-230/60	T - Constant Torque	000 - No Electric Heat	N - Non-Communicating	A - 1st Design

[ ] Designates Metric Conversions

Available Models
RHPAZR024AJT000NA
RHPAZR024AJT101NA
RHPAZR030AJT000NA
RHPAZR030AJT101NA
RHPAZR036AJT000NA
RHPAZR036AJT101NA
RHPAZR036AJT151NA
RHPXZR042AJT000NA
RHPXZR042AJT151NA
RHPXZR048AJT000NA
RHPXZR048AJT151NA
<b>RHPXZR060AJT000NA</b>
<b>RHPXZR060AJT151NA</b>

Note: **Bold** represents 2-stage cooling models.  
Further heater kits available to purchase for field installation.

## NOMINAL SIZES 2-5 TONS [7.03-17.6 kW]

Model RHPAZR- Series	024AJT	030AJT	036AJT
<b>Cooling Performance<sup>1</sup></b>			<b>CONTINUED</b> →
Gross Cooling Capacity Btu [kW]	23,800 [6.97]	30,000 [8.79]	35,000 [10.25]
EER/SEER <sup>2</sup>	10.6/13.4	10.6/13.4	10.6/13.4
Nominal CFM/AHRI Rated CFM [L/s]	800/875 [378/413]	1000/1080 [472/510]	1200/1180 [566/557]
AHRI Net Cooling Capacity Btu [kW]	23,000 [6.74]	29,000 [8.5]	34,200 [10.02]
Net Sensible Capacity Btu [kW]	16,700 [4.89]	21,700 [6.36]	25,400 [7.44]
Net Latent Capacity Btu [kW]	6,300 [1.85]	7,300 [2.14]	8,800 [2.58]
Net System Power kW	2.05	2.49	3.11
<b>Heating Performance (Heat Pumps)</b>			
High Temp. Btuh [kW] Rating	22,400 [6.56]	28,200 [8.26]	33,800 [9.9]
System Power KW / COP	1.77/3.5	2.26/3.6	2.85/3.58
Low Temp. Btuh [kW] Rating	13,000 [3.81]	14,400 [4.22]	20,600 [6.04]
System Power KW / COP	1.78/2	2.15/2	2.86/2
HSPF (Btu/Watts-hr)	6.7	6.7	6.7
<b>Compressor</b>			
No./Type	1/Scroll	1/Scroll	1/Scroll
<b>Outdoor Sound Rating (dB)<sup>4</sup></b>	74	77	78
<b>Outdoor Coil—Fin Type</b>	Louvered	Louvered	Louvered
Tube Type	Rifled	Rifled	Rifled
Tube Size in. [mm] OD	0.375 [9.5]	0.375 [9.5]	0.375 [9.5]
Face Area sq. ft. [sq. m]	14.51 [1.35]	16.32 [1.52]	16.32 [1.52]
Rows / FPI [FPcm]	1 / 22 [9]	1 / 22 [9]	1 / 22 [9]
Refrigerant Control	TX Valves	TX Valves	TX Valves
<b>Indoor Coil—Fin Type</b>	Louvered	Louvered	Louvered
Tube Type	MicroChannel	MicroChannel	MicroChannel
MicroChannel Depth in. [mm]	1 [25.4]	1.26 [32]	1.26 [32]
Face Area sq. ft. [sq. m]	3.54 [0.33]	3.98 [0.37]	3.98 [0.37]
Rows / FPI [FPcm]	1 / 20 [8]	1 / 20 [8]	1 / 20 [8]
Refrigerant Control	TX Valves	TX Valves	TX Valves
Drain Connection No./Size in. [mm]	1/0.75 [19.05]	1/0.75 [19.05]	1/0.75 [19.05]
<b>Outdoor Fan—Type</b>	Propeller	Propeller	Propeller
No. Used/Diameter in. [mm]	1/22 [558.8]	1/22 [558.8]	1/22 [558.8]
Drive Type/No. Speeds	Direct/1	Direct/1	Direct/1
CFM [L/s]	3400 [1604]	4200 [1982]	4200 [1982]
No. Motors/HP	1 at 1/3 HP	1 at 1/3 HP	1 at 1/3 HP
Motor RPM	825	1075	1075
<b>Indoor Fan—Type</b>	FC Centrifugal	FC Centrifugal	FC Centrifugal
No. Used/Diameter in. [mm]	1/10x9 [254x229]	1/12x9 [305x229]	1/12x9 [305x229]
Drive Type	Direct	Direct	Direct
No. Speeds	Multiple	Multiple	Multiple
No. Motors	1	1	1
Motor HP	1/3	1/2	1/2
Motor RPM	1050	1050	1050
Motor Frame Size	48	48	48
<b>Filter—Type</b>	Field Supplied	Field Supplied	Field Supplied
Furnished	No	No	No
(NO.) Size Recommended in. [mm x mm x mm]	(1)1x20x20 [25x508x508]	(1)1x24x24 [25x610x610]	(1)1x24x24 [25x610x610]
<b>Refrigerant Charge Oz. [g]</b>	102 [2892]	120 [3402]	110.4 [3130]
<b>Weights</b>			
Net Weight lbs. [kg]	360 [163]	410 [186]	415 [188]
Ship Weight lbs. [kg]	370 [168]	420 [191]	425 [193]

See Page 8 for Notes.

[ ] Designates Metric Conversions

## NOMINAL SIZES 2-5 TONS [7.03-17.6 kW]

Model RHPXZR- Series	042AJT	048AJT	060AJT
<b>Cooling Performance<sup>1</sup></b>			
Gross Cooling Capacity Btu [kW]	43,000 [12.6]	48,500 [14.21]	59,500 [17.43]
EER/SEER <sup>2</sup>	10.6/13.4	10.6/13.4	10.6/13.4
Nominal CFM/AHRI Rated CFM [L/s]	1400/1425 [661/672]	1600/1610 [755/760]	1600/1900 [755/897]
AHRI Net Cooling Capacity Btu [kW]	41,500 [12.16]	47,000 [13.77]	57,000 [16.7]
Net Sensible Capacity Btu [kW]	31,200 [9.14]	33,800 [9.9]	41,600 [12.19]
Net Latent Capacity Btu [kW]	10,300 [3.02]	13,200 [3.87]	15,400 [4.51]
Net System Power kW	3.48	4.02	5.17
<b>Heating Performance (Heat Pumps)</b>			
High Temp. Btuh [kW] Rating	40,000 [11.72]	46,000 [13.48]	56,000 [16.41]
System Power KW / COP	3.26/3.6	3.77/3.6	4.59/3.5
Low Temp. Btuh [kW] Rating	23,600 [6.91]	28,600 [8.38]	31,600 [9.26]
System Power KW / COP	2.98/2.3	3.5/2.3	4.27/2.3
HSPF (Btu/Watts-hr)	6.7	6.7	6.7
<b>Compressor</b>			
No./Type	1/Scroll	1/Scroll	1/Scroll
<b>Outdoor Sound Rating (dB)<sup>3</sup></b>			
	76	78	78
<b>Outdoor Coil—Fin Type</b>			
Tube Type	Louvered	Louvered	Louvered
Tube Type	MicroChannel	MicroChannel	MicroChannel
Tube Size in. [mm] OD	0.63 [16]	1 [25.4]	1.26 [32]
Face Area sq. ft. [sq. m]	16 [1.49]	16 [1.49]	16 [1.49]
Rows / FPI [FPcm]	1 / 16 [6]	1 / 16 [6]	1 / 16 [6]
Refrigerant Control	TX Valves	TX Valves	TX Valves
<b>Indoor Coil—Fin Type</b>			
Tube Type	Louvered	Louvered	Louvered
Tube Type	MicroChannel	MicroChannel	MicroChannel
MicroChannel Depth in. [mm]	1 [25.4]	1 [25.4]	1.26 [32]
Face Area sq. ft. [sq. m]	7.08 [0.66]	7.08 [0.66]	7.08 [0.66]
Rows / FPI [FPcm]	1 / 20 [8]	1 / 20 [8]	1 / 20 [8]
Refrigerant Control	TX Valves	TX Valves	TX Valves
Drain Connection No./Size in. [mm]	1/0.75 [19.05]	1/0.75 [19.05]	1/0.75 [19.05]
<b>Outdoor Fan—Type</b>			
Propeller	Propeller	Propeller	Propeller
No. Used/Diameter in. [mm]	1/24 [609.6]	1/24 [609.6]	1/24 [609.6]
Drive Type/No. Speeds	Direct/1	Direct/1	Direct/1
CFM [L/s]	4300 [2029]	4100 [1935]	4300 [2029]
No. Motors/HP	1 at 1/3 HP	1 at 1/3 HP	1 at 1/2 HP
Motor RPM	1050	1050	1075
<b>Indoor Fan—Type</b>			
FC Centrifugal	FC Centrifugal	FC Centrifugal	FC Centrifugal
No. Used/Diameter in. [mm]	1/12x9 [305x229]	1/12x9 [305x229]	1/12x9 [305x229]
Drive Type	Direct	Direct	Direct
No. Speeds	Multiple	Multiple	Multiple
No. Motors	1	1	1
Motor HP	3/4	3/4	1
Motor RPM	1050	1075	1050
Motor Frame Size	48	48	48
<b>Filter—Type</b>			
Field Supplied	Field Supplied	Field Supplied	Field Supplied
Furnished	No	No	No
(NO.) Size Recommended in. [mm x mm x mm]	(2)1x16x30 [25x406x762]	(2)1x16x30 [25x406x762]	(2)1x16x30 [25x406x762]
<b>Refrigerant Charge Oz. [g]</b>			
	96 [2722]	140.8 [3992]	160.5 [4550]
<b>Weights</b>			
Net Weight lbs. [kg]	496 [225]	516 [234]	533 [242]
Ship Weight lbs. [kg]	506 [230]	526 [239]	543 [246]

See Page 8 for Notes.

[ ] Designates Metric Conversions

## NOTES:

1. Cooling Performance is rated at 95°F ambient, 80°F entering dry bulb, 67°F entering wet bulb. Gross capacity does not include the effect of fan motor heat. ARI capacity is net and includes the effect of fan motor heat. Units are suitable for operation to  $\pm 20\%$  of nominal cfm. Units are certified in accordance with the Unitary Air Conditioner Equipment certification program, which is based on ARI Standard 210/240 or 360.
2. EER2 and/or SEER2 are rated at ARI conditions and in accordance with DOE test procedures for 1-Phase models. EER and/or SEER are rated at ARI conditions and in accordance with DOE test procedures for 3-Phase models.
3. HSPF2 is rated at ARI conditions and in accordance with DOE test procedures for 1-Phase models. HSPF is rated at ARI conditions and in accordance with DOE test procedures for 3-Phase models.
4. Outdoor Sound Rating shown is tested in accordance with ARI Standard 270.



## COOLING PERFORMANCE DATA—RHPAZR024AJT

ENTERING INDOOR AIR @ 80°F [26.7°C] dbE ①											
		wbE	71°F [21.7°C]			67°F [19.4°C]			63°F [17.2°C]		
		CFM [L/s]	900 [425]	875 [413]	700 [330]	900 [425]	875 [413]	700 [330]	900 [425]	875 [413]	700 [330]
		DR ①	0.24	0.24	0.28	0.24	0.24	0.28	0.24	0.24	0.28
OUTDOOR DRY BULB TEMPERATURE °F [°C]	75 [23.9]	Total BTUH [kW] Sens BTUH [kW] Power	29.9 [8.8] 16.8 [4.9] 1.5	29.8 [8.7] 16.5 [4.8] 1.5	28.7 [8.4] 14.0 [4.1] 1.4	27.9 [8.2] 20.0 [5.9] 1.4	27.8 [8.1] 19.6 [5.7] 1.4	26.8 [7.9] 16.9 [5.0] 1.4	26.3 [7.7] 22.4 [6.6] 1.4	26.1 [7.6] 21.9 [6.4] 1.4	25.2 [7.4] 19.0 [5.6] 1.4
	80 [26.7]	Total BTUH [kW] Sens BTUH [kW] Power	29.0 [8.5] 16.4 [4.8] 1.5	28.8 [8.4] 16.0 [4.7] 1.5	27.8 [8.1] 13.6 [4.0] 1.5	26.9 [7.9] 19.4 [5.7] 1.5	26.8 [7.9] 19.0 [5.6] 1.5	25.8 [7.6] 16.3 [4.8] 1.5	25.3 [7.4] 21.8 [6.4] 1.5	25.2 [7.4] 21.4 [6.3] 1.5	24.3 [7.1] 18.6 [5.4] 1.5
	85 [29.4]	Total BTUH [kW] Sens BTUH [kW] Power	28.0 [8.2] 15.8 [4.6] 1.6	27.8 [8.1] 15.4 [4.5] 1.6	26.8 [7.9] 13.1 [3.8] 1.6	26.0 [7.6] 18.9 [5.5] 1.6	25.8 [7.6] 18.5 [5.4] 1.6	24.9 [7.3] 16.0 [4.7] 1.6	24.3 [7.1] 21.3 [6.2] 1.6	24.2 [7.1] 20.9 [6.1] 1.6	23.3 [6.8] 18.1 [5.3] 1.6
	90 [32.2]	Total BTUH [kW] Sens BTUH [kW] Power	27.0 [7.9] 15.3 [4.5] 1.7	26.8 [7.9] 14.9 [4.4] 1.7	25.9 [7.6] 12.7 [3.7] 1.7	25.0 [7.3] 18.4 [5.4] 1.7	24.8 [7.3] 18.0 [5.3] 1.7	23.9 [7.0] 15.5 [4.5] 1.7	23.3 [6.8] 20.8 [6.1] 1.7	23.2 [6.8] 20.4 [6.0] 1.7	22.3 [6.5] 17.7 [5.2] 1.7
	95 [35]	Total BTUH [kW] Sens BTUH [kW] Power	26.0 [7.6] 14.9 [4.4] 1.8	25.8 [7.6] 14.5 [4.2] 1.8	24.9 [7.3] 12.3 [3.6] 1.8	23.9 [7.0] 17.8 [5.2] 1.8	23.8 [7.0] 17.5 [5.1] 1.8	22.9 [6.7] 15.1 [4.4] 1.8	22.3 [6.5] 20.3 [5.9] 1.8	22.2 [6.5] 19.9 [5.8] 1.8	21.4 [6.3] 17.3 [5.1] 1.8
	100 [37.8]	Total BTUH [kW] Sens BTUH [kW] Power	24.9 [7.3] 14.3 [4.2] 1.9	24.8 [7.3] 14.0 [4.1] 1.9	23.9 [7.0] 11.9 [3.5] 1.9	22.9 [6.7] 17.3 [5.1] 1.9	22.8 [6.7] 17.0 [5.0] 1.9	21.9 [6.4] 14.6 [4.3] 1.9	21.2 [6.2] 19.7 [5.8] 1.9	21.1 [6.2] 19.3 [5.7] 1.9	20.4 [6.0] 16.9 [5.0] 1.9
	105 [40.6]	Total BTUH [kW] Sens BTUH [kW] Power	23.9 [7.0] 13.8 [4.0] 2.0	23.7 [6.9] 13.4 [3.9] 2.0	22.9 [6.7] 11.4 [3.3] 2.0	21.8 [6.4] 16.8 [4.9] 2.0	21.7 [6.4] 16.5 [4.8] 2.0	20.9 [6.1] 14.2 [4.2] 2.0	20.2 [5.9] 19.3 [5.7] 2.0	20.1 [5.9] 18.9 [5.5] 2.0	19.4 [5.7] 16.5 [4.8] 2.0
	110 [43.3]	Total BTUH [kW] Sens BTUH [kW] Power	22.8 [6.7] 13.3 [3.9] 2.2	22.7 [6.7] 13.0 [3.8] 2.2	21.9 [6.4] 11.1 [3.3] 2.1	20.8 [6.1] 16.3 [4.8] 2.2	20.7 [6.1] 16.0 [4.7] 2.1	19.9 [5.8] 13.8 [4.0] 2.1	19.1 [5.6] 18.6 [5.4] 2.1	19.0 [5.6] 18.3 [5.4] 2.1	18.3 [5.4] 16.0 [4.7] 2.1
	115 [46.1]	Total BTUH [kW] Sens BTUH [kW] Power	21.7 [6.4] 12.8 [3.8] 2.3	21.6 [6.3] 12.5 [3.7] 2.3	20.8 [6.1] 10.6 [3.1] 2.2	19.7 [5.8] 15.8 [4.6] 2.3	19.6 [5.7] 15.5 [4.5] 2.3	18.9 [5.5] 13.4 [3.9] 2.2	18.0 [5.3] 18.0 [5.3] 2.3	18.0 [5.3] 17.9 [5.2] 2.3	17.3 [5.1] 15.6 [4.6] 2.2

DR —Depression ratio  
dbE —Entering air dry bulb  
wbE—Entering air wet bulb

Total —Total capacity x 1000 BTUH  
Sens —Sensible capacity x 1000 BTUH  
Power—KW input

**NOTES:**

① When the entering air dry bulb is other than 80°F [27°C], adjust the sensible capacity from the table by adding  $[1.10 \times \text{CFM} \times (1 - \text{DR}) \times (\text{dbE} - 80)]$ .

## HEATING PERFORMANCE DATA—RHPAZR024AJT

		IDB	60°F [15.5°C]			70°F [21.1°C]			80°F [26.7°C]		
		CFM [L/s]	7200 [3398]	6025 [2843]	4800 [2265]	7200 [3398]	6025 [2843]	4800 [2265]	7200 [3398]	6025 [2843]	4800 [2265]
OUTDOOR DRY BULB TEMPERATURE °F [°C]	0 [-17.8]	Total BTUH [kW] Power	6.0 [1.8] 1.1	6.0 [1.8] 1.1	5.9 [1.7] 1.2	4.8 [1.4] 1.3	4.8 [1.4] 1.3	4.8 [1.4] 1.3	3.7 [1.1] 1.5	3.7 [1.1] 1.5	3.6 [1.1] 1.5
	5 [-15]	Total BTUH [kW] Power	7.8 [2.3] 1.1	7.7 [2.3] 1.2	7.6 [2.2] 1.2	6.6 [1.9] 1.3	6.6 [1.9] 1.3	6.5 [1.9] 1.3	5.5 [1.6] 1.5	5.5 [1.6] 1.5	5.4 [1.6] 1.5
	10 [-12.2]	Total BTUH [kW] Power	9.5 [2.8] 1.2	9.5 [2.8] 1.2	9.4 [2.8] 1.2	8.4 [2.5] 1.3	8.4 [2.5] 1.3	8.3 [2.4] 1.4	7.3 [2.1] 1.5	7.3 [2.1] 1.5	7.2 [2.1] 1.6
	15 [-9.4]	Total BTUH [kW] Power	11.3 [3.3] 1.2	11.3 [3.3] 1.2	11.1 [3.3] 1.2	10.2 [3.0] 1.4	10.2 [3.0] 1.4	10.0 [2.9] 1.4	9.1 [2.7] 1.5	9.0 [2.6] 1.6	8.9 [2.6] 1.6
	20 [-6.7]	Total BTUH [kW] Power	13.1 [3.8] 1.2	13.1 [3.8] 1.2	12.9 [3.8] 1.3	12.0 [3.5] 1.4	12.0 [3.5] 1.4	11.8 [3.5] 1.4	10.9 [3.2] 1.6	10.8 [3.2] 1.6	10.7 [3.1] 1.6
	25 [-3.9]	Total BTUH [kW] Power	14.9 [4.4] 1.3	14.9 [4.4] 1.3	14.7 [4.3] 1.3	13.8 [4.0] 1.4	13.7 [4.0] 1.4	13.5 [4.0] 1.4	12.6 [3.7] 1.6	12.6 [3.7] 1.6	12.4 [3.6] 1.7
	30 [-1.1]	Total BTUH [kW] Power	16.7 [4.9] 1.3	16.7 [4.9] 1.3	16.4 [4.8] 1.3	15.6 [4.6] 1.4	15.5 [4.5] 1.4	15.3 [4.5] 1.5	14.4 [4.2] 1.6	14.4 [4.2] 1.6	14.2 [4.2] 1.7
	35 [1.7]	Total BTUH [kW] Power	18.5 [5.4] 1.3	18.4 [5.4] 1.3	18.2 [5.3] 1.4	17.3 [5.1] 1.5	17.3 [5.1] 1.5	17.1 [5.0] 1.5	16.2 [4.7] 1.7	16.2 [4.7] 1.7	15.9 [4.7] 1.7
	40 [4.4]	Total BTUH [kW] Power	20.3 [5.9] 1.3	20.2 [5.9] 1.4	19.9 [5.8] 1.4	19.1 [5.6] 1.5	19.1 [5.6] 1.5	18.8 [5.5] 1.5	18.0 [5.3] 1.7	18.0 [5.3] 1.7	17.7 [5.2] 1.7
	45 [7.2]	Total BTUH [kW] Power	22.1 [6.5] 1.4	22.0 [6.4] 1.4	21.7 [6.4] 1.4	20.9 [6.1] 1.5	20.9 [6.1] 1.5	20.6 [6.0] 1.6	19.8 [5.8] 1.7	19.7 [5.8] 1.7	19.5 [5.7] 1.8
50 [10]	Total BTUH [kW] Power	23.8 [7.0] 1.4	23.8 [7.0] 1.4	23.5 [6.9] 1.4	22.7 [6.7] 1.5	22.7 [6.7] 1.6	22.3 [6.5] 1.6	21.6 [6.3] 1.7	21.5 [6.3] 1.8	21.2 [6.2] 1.8	

IDB—Indoor air dry bulb

[ ] Designates Metric Conversions

## COOLING PERFORMANCE DATA—RHPAZR030AJT

ENTERING INDOOR AIR @ 80°F [26.7°C] dbE ①											
wbE		71°F [21.7°C]			67°F [19.4°C]			63°F [17.2°C]			
CFM [L/s]		1120 [529]	1080 [510]	880 [415]	1120 [529]	1080 [510]	880 [415]	1120 [529]	1080 [510]	880 [415]	
DR ①		0.18	0.19	0.22	0.18	0.19	0.22	0.18	0.19	0.22	
O U T D O O R  D R Y  B U L B  T E M P E R A T U R E  ° F [ ° C]	75 [23.9]	Total BTUH [kW] Sens BTUH [kW] Power	36.9 [10.8] 21.5 [6.3] 1.7	36.7 [10.8] 20.9 [6.1] 1.7	35.5 [10.4] 18.0 [5.3] 1.7	34.7 [10.2] 25.5 [7.5] 1.7	34.4 [10.1] 24.8 [7.3] 1.7	33.3 [9.8] 21.7 [6.4] 1.7	32.4 [9.5] 27.8 [8.1] 1.7	32.2 [9.4] 27.1 [7.9] 1.7	31.1 [9.1] 23.8 [7.0] 1.7
	80 [26.7]	Total BTUH [kW] Sens BTUH [kW] Power	35.9 [10.5] 21.1 [6.2] 1.8	35.7 [10.5] 20.5 [6.0] 1.8	34.5 [10.1] 17.6 [5.2] 1.8	33.6 [9.8] 25.0 [7.3] 1.8	33.4 [9.8] 24.4 [7.1] 1.8	32.3 [9.5] 21.3 [6.2] 1.8	31.3 [9.2] 27.3 [8.0] 1.8	31.1 [9.1] 26.6 [7.8] 1.8	30.1 [8.8] 23.4 [6.9] 1.8
	85 [29.4]	Total BTUH [kW] Sens BTUH [kW] Power	34.8 [10.2] 20.5 [6.0] 2.0	34.6 [10.1] 20.0 [5.9] 1.9	33.4 [9.8] 17.2 [5.0] 1.9	32.5 [9.5] 24.5 [7.2] 1.9	32.3 [9.5] 23.9 [7.0] 1.9	31.2 [9.1] 20.8 [6.1] 1.9	30.2 [8.8] 26.8 [7.9] 1.9	30.0 [8.8] 26.1 [7.6] 1.9	29.0 [8.5] 22.9 [6.7] 1.9
	90 [32.2]	Total BTUH [kW] Sens BTUH [kW] Power	33.6 [9.8] 19.8 [5.8] 2.1	33.4 [9.8] 19.3 [5.7] 2.1	32.3 [9.5] 16.6 [4.9] 2.0	31.4 [9.2] 24.0 [7.0] 2.1	31.2 [9.1] 23.4 [6.9] 2.1	30.1 [8.8] 20.4 [6.0] 2.0	29.1 [8.5] 26.2 [7.7] 2.0	28.9 [8.5] 25.6 [7.5] 2.0	27.9 [8.2] 22.5 [6.6] 2.0
	95 [35]	Total BTUH [kW] Sens BTUH [kW] Power	32.4 [9.5] 19.2 [5.6] 2.2	32.2 [9.4] 18.7 [5.5] 2.2	31.1 [9.1] 16.1 [4.7] 2.2	30.2 [8.8] 23.3 [6.8] 2.2	30.0 [8.8] 22.7 [6.7] 2.2	29.0 [8.5] 19.8 [5.8] 2.2	27.9 [8.2] 25.5 [7.5] 2.2	27.7 [8.1] 24.9 [7.3] 2.2	26.8 [7.9] 21.9 [6.4] 2.1
	100 [37.8]	Total BTUH [kW] Sens BTUH [kW] Power	31.2 [9.1] 18.5 [5.4] 2.4	31.0 [9.1] 18.0 [5.3] 2.4	29.9 [8.8] 15.4 [4.5] 2.4	28.9 [8.5] 22.5 [6.6] 2.4	28.7 [8.4] 21.9 [6.4] 2.4	27.7 [8.1] 19.1 [5.6] 2.3	26.6 [7.8] 24.7 [7.2] 2.4	26.4 [7.7] 24.1 [7.1] 2.3	25.5 [7.5] 21.2 [6.2] 2.3
	105 [40.6]	Total BTUH [kW] Sens BTUH [kW] Power	29.8 [8.7] 17.6 [5.2] 2.6	29.6 [8.7] 17.1 [5.0] 2.6	28.6 [8.4] 14.7 [4.3] 2.5	27.6 [8.1] 21.7 [6.4] 2.6	27.4 [8.0] 21.1 [6.2] 2.5	26.5 [7.8] 18.5 [5.4] 2.5	25.3 [7.4] 23.9 [7.0] 2.5	25.1 [7.4] 23.3 [6.8] 2.5	24.3 [7.1] 20.6 [6.0] 2.5
	110 [43.3]	Total BTUH [kW] Sens BTUH [kW] Power	28.5 [8.4] 16.7 [4.9] 2.8	28.3 [8.3] 16.2 [4.7] 2.8	27.3 [8.0] 13.9 [4.1] 2.7	26.2 [7.7] 20.8 [6.1] 2.8	26.0 [7.6] 20.2 [5.9] 2.7	25.1 [7.4] 17.6 [5.2] 2.7	23.9 [7.0] 23.0 [6.7] 2.7	23.7 [6.9] 22.4 [6.6] 2.7	22.9 [6.7] 19.7 [5.8] 2.7
	115 [46.1]	Total BTUH [kW] Sens BTUH [kW] Power	27.0 [7.9] 15.7 [4.6] 3.0	26.8 [7.9] 15.2 [4.5] 3.0	25.9 [7.6] 13.1 [3.8] 2.9	24.8 [7.3] 19.7 [5.8] 3.0	24.6 [7.2] 19.2 [5.6] 3.0	23.8 [7.0] 16.8 [4.9] 2.9	22.5 [6.6] 22.0 [6.4] 2.9	22.3 [6.5] 21.4 [6.3] 2.9	21.6 [6.3] 18.9 [5.5] 2.9

DR —Depression ratio  
dbE —Entering air dry bulb  
wbE—Entering air wet bulb

Total —Total capacity x 1000 BTUH  
Sens —Sensible capacity x 1000 BTUH  
Power—KW input

**NOTES:**

① When the entering air dry bulb is other than 80°F [27°C], adjust the sensible capacity from the table by adding [1.10 x CFM x (1 – DR) x (dbE – 80)].

## HEATING PERFORMANCE DATA—RHPAZR030AJT

ENTERING INDOOR AIR @ 80°F [26.7°C] dbE ①											
IDB		60°F [15.5°C]			70°F [21.1°C]			80°F [26.7°C]			
CFM [L/s]		1120 [529]	1080 [510]	880 [415]	1120 [529]	1080 [510]	880 [415]	1120 [529]	1080 [510]	880 [415]	
O U T D O O R  D R Y  B U L B  T E M P E R A T U R E  ° F [ ° C]	0 [-17.8]	Total BTUH [kW] Power	9.3 [2.7] 1.7	9.2 [2.7] 1.7	9.1 [2.7] 1.8	8.0 [2.3] 1.7	8.0 [2.3] 1.7	7.9 [2.3] 1.7	6.7 [2.0] 2.1	6.7 [2.0] 2.1	6.6 [1.9] 2.2
	5 [-15]	Total BTUH [kW] Power	11.3 [3.3] 1.8	11.3 [3.3] 1.8	11.1 [3.3] 1.8	10.0 [2.9] 1.7	10.0 [2.9] 1.7	9.9 [2.9] 1.7	8.8 [2.6] 2.2	8.7 [2.5] 2.2	8.6 [2.5] 2.2
	10 [-12.2]	Total BTUH [kW] Power	13.4 [3.9] 1.8	13.3 [3.9] 1.8	13.2 [3.9] 1.8	12.1 [3.5] 1.7	12.1 [3.5] 1.7	11.9 [3.5] 1.8	10.8 [3.2] 2.2	10.8 [3.2] 2.2	10.7 [3.1] 2.3
	15 [-9.4]	Total BTUH [kW] Power	15.4 [4.5] 1.8	15.4 [4.5] 1.8	15.2 [4.5] 1.9	14.2 [4.2] 1.8	14.1 [4.1] 1.8	13.9 [4.1] 1.8	12.9 [3.8] 2.2	12.8 [3.8] 2.2	12.7 [3.7] 2.3
	20 [-6.7]	Total BTUH [kW] Power	17.5 [5.1] 1.9	17.4 [5.1] 1.9	17.2 [5.0] 1.9	16.2 [4.7] 1.8	16.2 [4.7] 1.8	16.0 [4.7] 1.8	14.9 [4.4] 2.3	14.9 [4.4] 2.3	14.7 [4.3] 2.3
	25 [-3.9]	Total BTUH [kW] Power	19.5 [5.7] 1.9	19.5 [5.7] 1.9	19.2 [5.6] 1.9	18.3 [5.4] 1.8	18.2 [5.3] 1.8	18.0 [5.3] 1.9	17.0 [5.0] 2.3	17.0 [5.0] 2.3	16.7 [4.9] 2.4
	30 [-1.1]	Total BTUH [kW] Power	21.6 [6.3] 1.9	21.5 [6.3] 1.9	21.2 [6.2] 2.0	20.3 [5.9] 1.9	20.3 [5.9] 1.9	20.0 [5.9] 1.9	19.1 [5.6] 2.3	19.0 [5.6] 2.3	18.7 [5.5] 2.4
	35 [1.7]	Total BTUH [kW] Power	23.6 [6.9] 1.9	23.6 [6.9] 2.0	23.3 [6.8] 2.0	22.4 [6.6] 1.9	22.3 [6.5] 1.9	22.0 [6.4] 1.9	21.1 [6.2] 2.4	21.1 [6.2] 2.4	20.8 [6.1] 2.4
	40 [4.4]	Total BTUH [kW] Power	25.7 [7.5] 2.0	25.6 [7.5] 2.0	25.3 [7.4] 2.0	24.4 [7.1] 1.9	24.4 [7.1] 1.9	24.0 [7.0] 2.0	23.2 [6.8] 2.4	23.1 [6.8] 2.4	22.8 [6.7] 2.5
	45 [7.2]	Total BTUH [kW] Power	27.8 [8.1] 2.0	27.7 [8.1] 2.0	27.3 [8.0] 2.1	26.5 [7.8] 2.0	26.4 [7.7] 2.0	26.1 [7.6] 2.0	25.2 [7.4] 2.4	25.2 [7.4] 2.4	24.8 [7.3] 2.5
50 [10]	Total BTUH [kW] Power	29.8 [8.7] 2.0	29.7 [8.7] 2.1	29.3 [8.6] 2.1	28.5 [8.4] 2.0	28.5 [8.4] 2.0	28.1 [8.2] 2.0	27.3 [8.0] 2.5	27.2 [8.0] 2.5	26.8 [7.9] 2.5	

IDB—Indoor air dry bulb

[ ] Designates Metric Conversions

## COOLING PERFORMANCE DATA—RHPAZR036AJT

		ENTERING INDOOR AIR @ 80°F [26.7°C] dbE ①									
		wbE	71°F [21.7°C]			67°F [19.4°C]			63°F [17.2°C]		
		CFM [L/s]	1350 [637]	1180 [557]	1050 [496]	1350 [637]	1180 [557]	1050 [496]	1350 [637]	1180 [557]	1050 [496]
		DR ①	0.12	0.15	0.17	0.12	0.15	0.17	0.12	0.15	0.17
OUTDOOR DRY BULB TEMPERATURE	75 [23.9]	Total BTUH [kW] Sens BTUH [kW] Power	44.2 [13.0] 25.7 [7.5] 2.4	43.0 [12.6] 22.9 [6.7] 2.3	42.2 [12.4] 21.0 [6.2] 2.3	41.1 [12.0] 30.9 [9.1] 2.3	40.1 [11.7] 28.0 [8.2] 2.3	39.3 [11.5] 25.8 [7.6] 2.3	39.2 [11.5] 34.5 [10.1] 2.3	38.2 [11.2] 31.3 [9.2] 2.3	37.5 [11.0] 29.0 [8.5] 2.3
	80 [26.7]	Total BTUH [kW] Sens BTUH [kW] Power	43.1 [12.6] 25.4 [7.4] 2.5	42.0 [12.3] 22.7 [6.7] 2.4	41.1 [12.0] 20.7 [6.1] 2.4	40.0 [11.7] 30.6 [9.0] 2.5	39.0 [11.4] 27.7 [8.1] 2.4	38.2 [11.2] 25.5 [7.5] 2.4	38.1 [11.2] 34.3 [10.0] 2.5	37.2 [10.9] 31.2 [9.1] 2.4	36.4 [10.7] 28.8 [8.4] 2.4
	85 [29.4]	Total BTUH [kW] Sens BTUH [kW] Power	41.8 [12.2] 25.0 [7.3] 2.6	40.8 [12.0] 22.4 [6.6] 2.6	40.0 [11.7] 20.5 [6.0] 2.6	38.8 [11.4] 30.3 [8.9] 2.6	37.8 [11.1] 27.4 [8.0] 2.6	37.1 [10.9] 25.3 [7.4] 2.5	36.9 [10.8] 33.8 [9.9] 2.6	36.0 [10.5] 30.8 [9.0] 2.6	35.3 [10.3] 28.6 [8.4] 2.5
	90 [32.2]	Total BTUH [kW] Sens BTUH [kW] Power	40.5 [11.9] 24.4 [7.1] 2.8	39.4 [11.5] 21.8 [6.4] 2.7	38.7 [11.3] 20.0 [5.9] 2.7	37.4 [11.0] 29.7 [8.7] 2.7	36.5 [10.7] 26.9 [7.9] 2.7	35.8 [10.5] 24.9 [7.3] 2.7	35.6 [10.4] 33.3 [9.8] 2.7	34.7 [10.2] 30.3 [8.9] 2.7	34.0 [10.0] 28.1 [8.2] 2.7
	95 [35]	Total BTUH [kW] Sens BTUH [kW] Power	39.0 [11.4] 23.7 [6.9] 2.9	38.0 [11.1] 21.2 [6.2] 2.9	37.3 [10.9] 19.4 [5.7] 2.8	36.0 [10.5] 29.0 [8.5] 2.9	35.1 [10.3] 26.3 [7.7] 2.9	34.4 [10.1] 24.3 [7.1] 2.8	34.1 [10.0] 32.6 [9.6] 2.9	33.2 [9.7] 29.6 [8.7] 2.9	32.6 [9.6] 27.5 [8.1] 2.8
	100 [37.8]	Total BTUH [kW] Sens BTUH [kW] Power	37.4 [11.0] 22.8 [6.7] 3.1	36.5 [10.7] 20.5 [6.0] 3.0	35.7 [10.5] 18.7 [5.5] 3.0	34.4 [10.1] 28.2 [8.3] 3.1	33.5 [9.8] 25.5 [7.5] 3.0	32.8 [9.6] 23.5 [6.9] 3.0	32.5 [9.5] 31.7 [9.3] 3.1	31.7 [9.3] 28.9 [8.5] 3.0	31.0 [9.1] 26.8 [7.9] 3.0
	105 [40.6]	Total BTUH [kW] Sens BTUH [kW] Power	35.7 [10.5] 21.9 [6.4] 3.2	34.8 [10.2] 19.6 [5.7] 3.2	34.1 [10.0] 17.9 [5.2] 3.2	32.7 [9.6] 27.2 [8.0] 3.2	31.8 [9.3] 24.6 [7.2] 3.2	31.2 [9.1] 22.8 [6.7] 3.2	30.8 [9.0] 30.7 [9.0] 3.2	30.0 [8.8] 28.0 [8.2] 3.2	29.4 [8.6] 26.0 [7.6] 3.1
	110 [43.3]	Total BTUH [kW] Sens BTUH [kW] Power	33.8 [9.9] 20.7 [6.1] 3.4	33.0 [9.7] 18.6 [5.4] 3.4	32.3 [9.5] 17.0 [5.0] 3.3	30.8 [9.0] 26.0 [7.6] 3.4	30.0 [8.8] 23.6 [6.9] 3.4	29.4 [8.6] 21.8 [6.4] 3.3	28.9 [8.5] 28.9 [8.5] 3.4	28.2 [8.3] 27.0 [7.9] 3.4	27.6 [8.1] 25.0 [7.3] 3.3
	115 [46.1]	Total BTUH [kW] Sens BTUH [kW] Power	31.9 [9.3] 19.5 [5.7] 3.6	31.1 [9.1] 17.5 [5.1] 3.6	30.4 [8.9] 15.9 [4.7] 3.5	28.8 [8.4] 24.8 [7.3] 3.6	28.1 [8.2] 22.5 [6.6] 3.5	27.5 [8.1] 20.8 [6.1] 3.5	27.0 [7.9] 27.0 [7.9] 3.6	26.3 [7.7] 25.9 [7.6] 3.5	25.7 [7.5] 24.0 [7.0] 3.5

DR —Depression ratio  
dbE —Entering air dry bulb  
wbE—Entering air wet bulb

Total —Total capacity x 1000 BTUH  
Sens —Sensible capacity x 1000 BTUH  
Power—KW input

NOTES:  
① When the entering air dry bulb is other than 80°F [27°C], adjust the sensible capacity from the table by adding [1.10 x CFM x (1 – DR) x (dbE – 80)].

## HEATING PERFORMANCE DATA—RHPAZR036AJT

		IDB	60°F [15.5°C]			70°F [21.1°C]			80°F [26.7°C]		
		CFM [L/s]	1350 [637]	1180 [557]	1050 [496]	1350 [637]	1180 [557]	1050 [496]	1350 [637]	1180 [557]	1050 [496]
OUTDOOR DRY BULB TEMPERATURE	0 [-17.8]	Total BTUH [kW] Power	10.1 [3.0] 1.8	10.0 [2.9] 1.8	9.9 [2.9] 1.9	9.5 [2.8] 2.0	9.4 [2.8] 2.1	9.3 [2.7] 2.1	8.8 [2.6] 2.4	8.7 [2.5] 2.4	8.7 [2.5] 2.4
	5 [-15]	Total BTUH [kW] Power	12.6 [3.7] 1.9	12.5 [3.7] 1.9	12.4 [3.6] 1.9	12.0 [3.5] 2.1	11.9 [3.5] 2.1	11.8 [3.5] 2.2	11.4 [3.3] 2.4	11.3 [3.3] 2.5	11.2 [3.3] 2.5
	10 [-12.2]	Total BTUH [kW] Power	15.2 [4.5] 1.9	15.0 [4.4] 1.9	14.9 [4.4] 2.0	14.5 [4.2] 2.1	14.4 [4.2] 2.2	14.3 [4.2] 2.2	13.9 [4.1] 2.5	13.8 [4.0] 2.5	13.7 [4.0] 2.5
	15 [-9.4]	Total BTUH [kW] Power	17.7 [5.2] 2.0	17.5 [5.1] 2.0	17.4 [5.1] 2.0	17.1 [5.0] 2.2	16.9 [5.0] 2.2	16.8 [4.9] 2.3	16.4 [4.8] 2.5	16.3 [4.8] 2.6	16.1 [4.7] 2.6
	20 [-6.7]	Total BTUH [kW] Power	20.2 [5.9] 2.0	20.0 [5.9] 2.1	19.9 [5.8] 2.1	19.6 [5.7] 2.3	19.4 [5.7] 2.3	19.3 [5.7] 2.3	19.0 [5.6] 2.6	18.8 [5.5] 2.6	18.6 [5.4] 2.7
	25 [-3.9]	Total BTUH [kW] Power	22.8 [6.7] 2.1	22.5 [6.6] 2.1	22.4 [6.6] 2.1	22.1 [6.5] 2.3	21.9 [6.4] 2.4	21.7 [6.4] 2.4	21.5 [6.3] 2.6	21.3 [6.2] 2.7	21.1 [6.2] 2.7
	30 [-1.1]	Total BTUH [kW] Power	25.3 [7.4] 2.1	25.1 [7.4] 2.2	24.9 [7.3] 2.2	24.7 [7.2] 2.4	24.4 [7.1] 2.4	24.2 [7.1] 2.4	24.0 [7.0] 2.7	23.8 [7.0] 2.7	23.6 [6.9] 2.8
	35 [1.7]	Total BTUH [kW] Power	27.8 [8.1] 2.2	27.6 [8.1] 2.2	27.3 [8.0] 2.3	27.2 [8.0] 2.4	26.9 [7.9] 2.5	26.7 [7.8] 2.5	26.6 [7.8] 2.7	26.3 [7.7] 2.8	26.1 [7.6] 2.8
	40 [4.4]	Total BTUH [kW] Power	30.4 [8.9] 2.2	30.1 [8.8] 2.3	29.8 [8.7] 2.3	29.7 [8.7] 2.5	29.4 [8.6] 2.5	29.2 [8.6] 2.6	29.1 [8.5] 2.8	28.8 [8.4] 2.8	28.6 [8.4] 2.9
	45 [7.2]	Total BTUH [kW] Power	32.9 [9.6] 2.3	32.6 [9.6] 2.3	32.3 [9.5] 2.4	32.3 [9.5] 2.5	31.9 [9.3] 2.6	31.7 [9.3] 2.6	31.6 [9.3] 2.9	31.3 [9.2] 2.9	31.1 [9.1] 2.9
50 [10]	Total BTUH [kW] Power	35.4 [10.4] 2.3	35.1 [10.3] 2.4	34.8 [10.2] 2.4	34.8 [10.2] 2.6	34.5 [10.1] 2.6	34.2 [10.0] 2.7	34.2 [10.0] 2.9	33.8 [9.9] 3.0	33.6 [9.8] 3.0	

IDB—Indoor air dry bulb

[ ] Designates Metric Conversions

## COOLING PERFORMANCE DATA—RHPXZR042AJT

ENTERING INDOOR AIR @ 80°F [26.7°C] dbE ①											
wbE		71°F [21.7°C]			67°F [19.4°C]			63°F [17.2°C]			
CFM [L/s]		1580 [746]	1425 [673]	1220 [576]	1580 [746]	1425 [673]	1220 [576]	1580 [746]	1425 [673]	1220 [576]	
DR ①		0.1	0.11	0.14	0.1	0.11	0.14	0.1	0.11	0.14	
OUTDOOR DRY BULB TEMPERATURE °F [°C]	75 [23.9]	Total BTUH [kW] Sens BTUH [kW] Power	54.0 [15.8] 33.6 [9.8] 2.4	52.9 [15.5] 30.9 [9.1] 2.4	51.5 [15.1] 27.5 [8.1] 2.4	50.1 [14.7] 38.7 [11.3] 2.4	49.1 [14.4] 35.8 [10.5] 2.4	47.8 [14.0] 32.2 [9.4] 2.4	47.0 [13.8] 42.2 [12.4] 2.4	46.1 [13.5] 39.3 [11.5] 2.4	44.9 [13.2] 35.5 [10.4] 2.4
	80 [26.7]	Total BTUH [kW] Sens BTUH [kW] Power	52.5 [15.4] 32.8 [9.6] 2.6	51.4 [15.1] 30.1 [8.8] 2.6	50.1 [14.7] 26.9 [7.9] 2.5	48.5 [14.2] 37.7 [11.0] 2.6	47.6 [13.9] 35.0 [10.3] 2.5	46.4 [13.6] 31.5 [9.2] 2.5	45.5 [13.3] 41.5 [12.2] 2.6	44.6 [13.1] 38.6 [11.3] 2.5	43.4 [12.7] 34.9 [10.2] 2.5
	85 [29.4]	Total BTUH [kW] Sens BTUH [kW] Power	50.9 [14.9] 31.9 [9.3] 2.7	49.9 [14.6] 29.4 [8.6] 2.7	48.6 [14.2] 26.2 [7.7] 2.7	47.0 [13.8] 37.0 [10.8] 2.7	46.1 [13.5] 34.3 [10.0] 2.7	44.9 [13.2] 30.9 [9.1] 2.7	43.9 [12.9] 40.6 [11.9] 2.7	43.0 [12.6] 37.7 [11.0] 2.7	41.9 [12.3] 34.1 [10.0] 2.7
	90 [32.2]	Total BTUH [kW] Sens BTUH [kW] Power	49.3 [14.4] 31.0 [9.1] 2.9	48.3 [14.2] 28.5 [8.4] 2.9	47.1 [13.8] 25.5 [7.5] 2.9	45.4 [13.3] 36.1 [10.6] 2.9	44.5 [13.0] 33.5 [9.8] 2.9	43.3 [12.7] 30.1 [8.8] 2.9	42.3 [12.4] 39.7 [11.6] 2.9	41.5 [12.2] 37.0 [10.8] 2.9	40.4 [11.8] 33.5 [9.8] 2.8
	95 [35]	Total BTUH [kW] Sens BTUH [kW] Power	47.6 [13.9] 30.1 [8.8] 3.1	46.7 [13.7] 27.7 [8.1] 3.1	45.5 [13.3] 24.7 [7.2] 3.0	43.7 [12.8] 35.1 [10.3] 3.1	42.9 [12.6] 32.6 [9.6] 3.1	41.8 [12.2] 29.4 [8.6] 3.0	40.6 [11.9] 38.7 [11.3] 3.1	39.9 [11.7] 36.1 [10.6] 3.1	38.8 [11.4] 32.7 [9.6] 3.0
	100 [37.8]	Total BTUH [kW] Sens BTUH [kW] Power	46.0 [13.5] 29.1 [8.5] 3.3	45.1 [13.2] 26.8 [7.9] 3.3	43.9 [12.9] 23.9 [7.0] 3.2	42.1 [12.3] 34.1 [10.0] 3.3	41.2 [12.1] 31.6 [9.3] 3.3	40.2 [11.8] 28.5 [8.4] 3.2	39.0 [11.4] 37.8 [11.1] 3.3	38.2 [11.2] 35.2 [10.3] 3.3	37.2 [10.9] 31.9 [9.3] 3.2
	105 [40.6]	Total BTUH [kW] Sens BTUH [kW] Power	44.3 [13.0] 28.2 [8.3] 3.5	43.4 [12.7] 25.9 [7.6] 3.5	42.3 [12.4] 23.1 [6.8] 3.5	40.4 [11.8] 33.2 [9.7] 3.5	39.6 [11.6] 30.8 [9.0] 3.5	38.5 [11.3] 27.7 [8.1] 3.4	37.3 [10.9] 36.8 [10.8] 3.5	36.5 [10.7] 34.2 [10.0] 3.5	35.6 [10.4] 31.1 [9.1] 3.4
	110 [43.3]	Total BTUH [kW] Sens BTUH [kW] Power	42.5 [12.5] 27.0 [7.9] 3.8	41.7 [12.2] 24.9 [7.3] 3.7	40.6 [11.9] 22.2 [6.5] 3.7	38.6 [11.3] 32.0 [9.4] 3.7	37.9 [11.1] 29.8 [8.7] 3.7	36.9 [10.8] 26.9 [7.9] 3.7	35.5 [10.4] 35.5 [10.4] 3.7	34.8 [10.2] 33.2 [9.7] 3.7	33.9 [9.9] 30.1 [8.8] 3.7
	115 [46.1]	Total BTUH [kW] Sens BTUH [kW] Power	40.7 [11.9] 25.8 [7.6] 4.0	39.9 [11.7] 23.8 [7.0] 4.0	38.9 [11.4] 21.3 [6.2] 3.9	36.8 [10.8] 30.9 [9.1] 4.0	36.1 [10.6] 28.7 [8.4] 3.9	35.2 [10.3] 25.9 [7.6] 3.9	33.7 [9.9] 33.7 [9.9] 4.0	33.1 [9.7] 32.3 [9.5] 3.9	32.2 [9.4] 29.3 [8.6] 3.9

DR —Depression ratio  
dbE —Entering air dry bulb  
wbE—Entering air wet bulb

Total —Total capacity x 1000 BTUH  
Sens —Sensible capacity x 1000 BTUH  
Power —kW input

**NOTES:**

① When the entering air dry bulb is other than 80°F [27°C], adjust the sensible capacity from the table by adding [1.10 x CFM x (1 - DR) x (dbE - 80)].

## HEATING PERFORMANCE DATA—RHPXZR042AJT

IDB		60°F [15.5°C]			70°F [21.1°C]			80°F [26.7°C]			
CFM [L/s]		1580 [746]	1425 [673]	1220 [576]	1580 [746]	1425 [673]	1220 [576]	1580 [746]	1425 [673]	1220 [576]	
OUTDOOR DRY BULB TEMPERATURE °F [°C]	0 [-17.8]	Total BTUH [kW] Power	12.0 [3.5] 2.0	11.9 [3.5] 2.0	11.7 [3.4] 2.0	11.2 [3.3] 2.2	11.1 [3.3] 2.2	11.0 [3.2] 2.3	10.4 [3.0] 2.8	10.3 [3.0] 2.8	10.2 [3.0] 2.9
	5 [-15]	Total BTUH [kW] Power	14.9 [4.4] 2.0	14.8 [4.3] 2.1	14.6 [4.3] 2.1	14.1 [4.1] 2.3	14.0 [4.1] 2.3	13.9 [4.1] 2.3	13.4 [3.9] 2.8	13.3 [3.9] 2.9	13.1 [3.8] 2.9
	10 [-12.2]	Total BTUH [kW] Power	17.9 [5.2] 2.1	17.7 [5.2] 2.1	17.5 [5.1] 2.2	17.1 [5.0] 2.3	17.0 [5.0] 2.4	16.8 [4.9] 2.4	16.3 [4.8] 2.9	16.2 [4.7] 2.9	16.0 [4.7] 3.0
	15 [-9.4]	Total BTUH [kW] Power	20.8 [6.1] 2.2	20.6 [6.0] 2.2	20.4 [6.0] 2.2	20.0 [5.9] 2.4	19.9 [5.8] 2.4	19.7 [5.8] 2.5	19.3 [5.7] 3.0	19.1 [5.6] 3.0	18.9 [5.5] 3.1
	20 [-6.7]	Total BTUH [kW] Power	23.8 [7.0] 2.2	23.6 [6.9] 2.3	23.3 [6.8] 2.3	23.0 [6.7] 2.5	22.8 [6.7] 2.5	22.6 [6.6] 2.5	22.2 [6.5] 3.0	22.0 [6.4] 3.1	21.8 [6.4] 3.1
	25 [-3.9]	Total BTUH [kW] Power	26.7 [7.8] 2.3	26.5 [7.8] 2.3	26.2 [7.7] 2.4	25.9 [7.6] 2.5	25.7 [7.5] 2.6	25.5 [7.5] 2.6	25.2 [7.4] 3.1	25.0 [7.3] 3.1	24.7 [7.2] 3.2
	30 [-1.1]	Total BTUH [kW] Power	29.7 [8.7] 2.4	29.4 [8.6] 2.4	29.1 [8.5] 2.5	28.9 [8.5] 2.6	28.7 [8.4] 2.6	28.4 [8.3] 2.7	28.1 [8.2] 3.2	27.9 [8.2] 3.2	27.6 [8.1] 3.3
	35 [1.7]	Total BTUH [kW] Power	32.6 [9.6] 2.4	32.4 [9.5] 2.5	32.0 [9.4] 2.5	31.8 [9.3] 2.7	31.6 [9.3] 2.7	31.3 [9.2] 2.7	31.1 [9.1] 3.2	30.8 [9.0] 3.3	30.5 [8.9] 3.3
	40 [4.4]	Total BTUH [kW] Power	35.6 [10.4] 2.5	35.3 [10.3] 2.5	34.9 [10.2] 2.6	34.8 [10.2] 2.7	34.5 [10.1] 2.8	34.2 [10.0] 2.8	34.0 [10.0] 3.3	33.7 [9.9] 3.3	33.4 [9.8] 3.4
	45 [7.2]	Total BTUH [kW] Power	38.5 [11.3] 2.6	38.2 [11.2] 2.6	37.8 [11.1] 2.7	37.7 [11.0] 2.8	37.4 [11.0] 2.8	37.1 [10.9] 2.9	37.0 [10.8] 3.4	36.7 [10.8] 3.4	36.3 [10.6] 3.5
50 [10]	Total BTUH [kW] Power	41.5 [12.2] 2.6	41.1 [12.0] 2.7	40.7 [11.9] 2.7	40.7 [11.9] 2.8	40.4 [11.8] 2.9	39.9 [11.7] 2.9	39.9 [11.7] 3.4	39.6 [11.6] 3.5	39.2 [11.5] 3.5	

IDB—Indoor air dry bulb

[ ] Designates Metric Conversions

## COOLING PERFORMANCE DATA—RHPXZR048AJT

ENTERING INDOOR AIR @ 80°F [26.7°C] dbE ①											
wbE		71°F [21.7°C]			67°F [19.4°C]			63°F [17.2°C]			
CFM [L/s]		1800 [850]	1610 [760]	1400 [661]	1800 [850]	1610 [760]	1400 [661]	1800 [850]	1610 [760]	1400 [661]	
DR ①		0.15	0.18	0.21	0.15	0.18	0.21	0.15	0.18	0.21	
OUTDOOR DRY BULB TEMPERATURE °F [°C]	75 [23.9]	Total BTUH [kW] Sens BTUH [kW] Power	60.6 [17.8] 36.0 [10.5] 2.8	59.3 [17.4] 32.8 [9.6] 2.8	57.9 [17.0] 29.5 [8.6] 2.8	56.4 [16.5] 41.9 [12.3] 2.8	55.3 [16.2] 38.6 [11.3] 2.8	54.0 [15.8] 35.0 [10.3] 2.7	52.5 [15.4] 46.2 [13.5] 2.8	51.4 [15.1] 42.7 [12.5] 2.8	50.2 [14.7] 39.0 [11.4] 2.7
	80 [26.7]	Total BTUH [kW] Sens BTUH [kW] Power	58.9 [17.3] 35.0 [10.3] 3.0	57.7 [16.9] 32.0 [9.4] 3.0	56.3 [16.5] 28.7 [8.4] 2.9	54.8 [16.1] 41.1 [12.0] 3.0	53.6 [15.7] 37.8 [11.1] 3.0	52.3 [15.3] 34.3 [10.0] 2.9	50.9 [14.9] 45.4 [13.3] 3.0	49.8 [14.6] 41.9 [12.3] 2.9	48.6 [14.2] 38.2 [11.2] 2.9
	85 [29.4]	Total BTUH [kW] Sens BTUH [kW] Power	57.2 [16.8] 34.2 [10.0] 3.2	56.0 [16.4] 31.2 [9.1] 3.2	54.7 [16.0] 28.1 [8.2] 3.1	53.1 [15.6] 40.2 [11.8] 3.2	52.0 [15.2] 37.0 [10.8] 3.1	50.7 [14.9] 33.5 [9.8] 3.1	49.2 [14.4] 44.5 [13.0] 3.1	48.1 [14.1] 41.1 [12.0] 3.1	47.0 [13.8] 37.6 [11.0] 3.1
	90 [32.2]	Total BTUH [kW] Sens BTUH [kW] Power	55.5 [16.3] 33.3 [9.8] 3.4	54.4 [15.9] 30.5 [8.9] 3.4	53.1 [15.6] 27.4 [8.0] 3.3	51.4 [15.1] 39.4 [11.5] 3.4	50.3 [14.7] 36.2 [10.6] 3.3	49.1 [14.4] 32.9 [9.6] 3.3	47.5 [13.9] 43.6 [12.8] 3.3	46.5 [13.6] 40.3 [11.8] 3.3	45.4 [13.3] 36.8 [10.8] 3.3
	95 [35]	Total BTUH [kW] Sens BTUH [kW] Power	53.8 [15.8] 32.4 [9.5] 3.6	52.7 [15.4] 29.6 [8.7] 3.6	51.5 [15.1] 26.7 [7.8] 3.5	49.7 [14.6] 38.5 [11.3] 3.6	48.6 [14.2] 35.4 [10.4] 3.5	47.5 [13.9] 32.2 [9.4] 3.5	45.8 [13.4] 42.7 [12.5] 3.5	44.8 [13.1] 39.5 [11.6] 3.5	43.7 [12.8] 36.1 [10.6] 3.5
	100 [37.8]	Total BTUH [kW] Sens BTUH [kW] Power	52.1 [15.3] 31.5 [9.2] 3.8	51.0 [14.9] 28.8 [8.4] 3.8	49.8 [14.6] 25.9 [7.6] 3.7	48.0 [14.1] 37.7 [11.0] 3.8	47.0 [13.8] 34.7 [10.2] 3.8	45.9 [13.4] 31.6 [9.3] 3.7	44.1 [12.9] 41.9 [12.3] 3.8	43.1 [12.6] 38.7 [11.3] 3.7	42.1 [12.3] 35.4 [10.4] 3.7
	105 [40.6]	Total BTUH [kW] Sens BTUH [kW] Power	50.4 [14.8] 30.8 [9.0] 4.1	49.4 [14.5] 28.2 [8.3] 4.0	48.2 [14.1] 25.4 [7.4] 4.0	46.3 [13.6] 36.8 [10.8] 4.0	45.3 [13.3] 33.9 [9.9] 4.0	44.2 [13.0] 30.8 [9.0] 4.0	42.3 [12.4] 40.9 [12.0] 4.0	41.4 [12.1] 37.9 [11.1] 4.0	40.5 [11.9] 34.7 [10.2] 3.9
	110 [43.3]	Total BTUH [kW] Sens BTUH [kW] Power	48.7 [14.3] 30.0 [8.8] 4.3	47.7 [14.0] 27.4 [8.0] 4.3	46.5 [13.6] 24.6 [7.2] 4.2	44.5 [13.0] 36.0 [10.5] 4.3	43.6 [12.8] 33.2 [9.7] 4.2	42.6 [12.5] 30.2 [8.8] 4.2	40.6 [11.9] 40.2 [11.8] 4.3	39.8 [11.7] 37.3 [10.9] 4.2	38.8 [11.4] 34.1 [10.0] 4.2
	115 [46.1]	Total BTUH [kW] Sens BTUH [kW] Power	47.0 [13.8] 29.1 [8.5] 4.6	46.0 [13.5] 26.6 [7.8] 4.5	44.9 [13.2] 23.9 [7.0] 4.5	42.8 [12.5] 35.1 [10.3] 4.6	41.9 [12.3] 32.4 [9.5] 4.5	40.9 [12.0] 29.5 [8.6] 4.5	38.9 [11.4] 38.9 [11.4] 4.5	38.1 [11.2] 36.5 [10.7] 4.5	37.2 [10.9] 33.4 [9.8] 4.4

DR —Depression ratio  
dbE —Entering air dry bulb  
wbE—Entering air wet bulb

Total —Total capacity x 1000 BTUH  
Sens —Sensible capacity x 1000 BTUH  
Power—KW input

**NOTES:**

① When the entering air dry bulb is other than 80°F [27°C], adjust the sensible capacity from the table by adding  $[1.10 \times \text{CFM} \times (1 - \text{DR}) \times (\text{dbE} - 80)]$ .

## HEATING PERFORMANCE DATA—RHPXZR048AJT

IDB		60°F [15.5°C]			70°F [21.1°C]			80°F [26.7°C]			
CFM [L/s]		1800 [850]	1610 [760]	1400 [661]	1800 [850]	1610 [760]	1400 [661]	1800 [850]	1610 [760]	1400 [661]	
OUTDOOR DRY BULB TEMPERATURE °F [°C]	0 [-17.8]	Total BTUH [kW] Power	15.8 [4.6] 2.3	15.6 [4.6] 2.4	15.5 [4.5] 2.4	14.4 [4.2] 2.7	14.3 [4.2] 2.8	14.2 [4.2] 2.8	13.1 [3.8] 3.1	13.0 [3.8] 3.1	12.9 [3.8] 3.2
	5 [-15]	Total BTUH [kW] Power	19.0 [5.6] 2.4	18.8 [5.5] 2.4	18.7 [5.5] 2.5	17.7 [5.2] 2.8	17.5 [5.1] 2.8	17.3 [5.1] 2.9	16.3 [4.8] 3.2	16.2 [4.7] 3.2	16.0 [4.7] 3.3
	10 [-12.2]	Total BTUH [kW] Power	22.2 [6.5] 2.5	22.0 [6.4] 2.5	21.8 [6.4] 2.5	20.9 [6.1] 2.8	20.7 [6.1] 2.9	20.5 [6.0] 2.9	19.5 [5.7] 3.2	19.4 [5.7] 3.3	19.2 [5.6] 3.3
	15 [-9.4]	Total BTUH [kW] Power	25.4 [7.4] 2.5	25.2 [7.4] 2.5	25.0 [7.3] 2.6	24.1 [7.1] 2.9	23.9 [7.0] 2.9	23.7 [6.9] 3.0	22.8 [6.7] 3.3	22.6 [6.6] 3.3	22.4 [6.6] 3.4
	20 [-6.7]	Total BTUH [kW] Power	28.7 [8.4] 2.6	28.4 [8.3] 2.6	28.2 [8.3] 2.6	27.3 [8.0] 2.9	27.1 [7.9] 3.0	26.8 [7.9] 3.0	26.0 [7.6] 3.3	25.8 [7.6] 3.4	25.5 [7.5] 3.4
	25 [-3.9]	Total BTUH [kW] Power	31.9 [9.3] 2.6	31.6 [9.3] 2.7	31.3 [9.2] 2.7	30.5 [8.9] 3.0	30.3 [8.9] 3.0	30.0 [8.8] 3.1	29.2 [8.6] 3.4	29.0 [8.5] 3.4	28.7 [8.4] 3.5
	30 [-1.1]	Total BTUH [kW] Power	35.1 [10.3] 2.7	34.8 [10.2] 2.7	34.5 [10.1] 2.8	33.8 [9.9] 3.1	33.5 [9.8] 3.1	33.2 [9.7] 3.1	32.4 [9.5] 3.4	32.2 [9.4] 3.5	31.9 [9.3] 3.5
	35 [1.7]	Total BTUH [kW] Power	38.3 [11.2] 2.7	38.0 [11.1] 2.8	37.7 [11.0] 2.8	37.0 [10.8] 3.1	36.7 [10.8] 3.2	36.3 [10.6] 3.2	35.7 [10.5] 3.5	35.4 [10.4] 3.5	35.0 [10.3] 3.6
	40 [4.4]	Total BTUH [kW] Power	41.6 [12.2] 2.8	41.2 [12.1] 2.8	40.8 [12.0] 2.9	40.2 [11.8] 3.2	39.9 [11.7] 3.2	39.5 [11.6] 3.3	38.9 [11.4] 3.5	38.6 [11.3] 3.6	38.2 [11.2] 3.7
	45 [7.2]	Total BTUH [kW] Power	44.8 [13.1] 2.8	44.4 [13.0] 2.9	44.0 [12.9] 2.9	43.4 [12.7] 3.2	43.1 [12.6] 3.3	42.7 [12.5] 3.3	42.1 [12.3] 3.6	41.8 [12.2] 3.7	41.4 [12.1] 3.7
50 [10]	Total BTUH [kW] Power	48.0 [14.1] 2.9	47.6 [13.9] 2.9	47.2 [13.8] 3.0	46.7 [13.7] 3.3	46.3 [13.6] 3.3	45.8 [13.4] 3.4	45.3 [13.3] 3.7	44.9 [13.2] 3.7	44.5 [13.0] 3.8	

IDB—Indoor air dry bulb

[ ] Designates Metric Conversions



## COOLING PERFORMANCE DATA—RHPXZR060AJT

ENTERING INDOOR AIR @ 80°F [26.7°C] dbE ①											
wbE		71°F [21.7°C]			67°F [19.4°C]			63°F [17.2°C]			
CFM [L/s]		2100 [991]	1900 [897]	1600 [755]	2100 [991]	1900 [897]	1600 [755]	2100 [991]	1900 [897]	1600 [755]	
DR ①		0.1	0.12	0.16	0.1	0.12	0.16	0.1	0.12	0.16	
OUTDOOR DRY BULB TEMPERATURE °F [°C]	75 [23.9]	Total BTUH [kW] Sens BTUH [kW] Power	71.5 [20.9] 44.9 [13.2] 3.8	70.1 [20.5] 41.4 [12.1] 3.7	68.1 [20.0] 36.5 [10.7] 3.7	67.3 [19.7] 50.8 [14.9] 3.7	66.1 [19.4] 47.2 [13.8] 3.7	64.2 [18.8] 42.0 [12.3] 3.6	63.4 [18.6] 55.1 [16.1] 3.7	62.2 [18.2] 51.3 [15.0] 3.7	60.5 [17.7] 45.9 [13.4] 3.6
	80 [26.7]	Total BTUH [kW] Sens BTUH [kW] Power	69.8 [20.5] 44.0 [12.9] 3.9	68.5 [20.1] 40.6 [11.9] 3.9	66.5 [19.5] 35.8 [10.5] 3.8	65.7 [19.2] 50.0 [14.6] 3.9	64.4 [18.9] 46.4 [13.6] 3.9	62.6 [18.3] 41.3 [12.1] 3.8	61.8 [18.1] 54.2 [15.9] 3.9	60.6 [17.8] 50.5 [14.8] 3.8	58.9 [17.3] 45.2 [13.2] 3.8
	85 [29.4]	Total BTUH [kW] Sens BTUH [kW] Power	68.1 [20.0] 43.1 [12.6] 4.1	66.8 [19.6] 39.8 [11.7] 4.1	64.9 [19.0] 35.1 [10.3] 4.0	64.0 [18.8] 49.1 [14.4] 4.1	62.8 [18.4] 45.6 [13.4] 4.0	61.0 [17.9] 40.6 [11.9] 4.0	60.1 [17.6] 53.4 [15.6] 4.1	58.9 [17.3] 49.7 [14.6] 4.0	57.3 [16.8] 44.6 [13.1] 4.0
	90 [32.2]	Total BTUH [kW] Sens BTUH [kW] Power	66.4 [19.5] 42.3 [12.4] 4.3	65.2 [19.1] 39.1 [11.5] 4.3	63.3 [18.5] 34.5 [10.1] 4.2	62.3 [18.3] 48.3 [14.2] 4.3	61.1 [17.9] 44.8 [13.1] 4.2	59.4 [17.4] 39.9 [11.7] 4.2	58.4 [17.1] 52.5 [15.4] 4.3	57.3 [16.8] 48.9 [14.3] 4.2	55.6 [16.3] 43.7 [12.8] 4.2
	95 [35]	Total BTUH [kW] Sens BTUH [kW] Power	64.7 [19.0] 41.3 [12.1] 4.5	63.5 [18.6] 38.2 [11.2] 4.5	61.7 [18.1] 33.7 [9.9] 4.4	60.6 [17.8] 47.4 [13.9] 4.5	59.5 [17.4] 44.1 [12.9] 4.5	57.7 [16.9] 39.2 [11.5] 4.4	56.7 [16.6] 51.6 [15.1] 4.5	55.6 [16.3] 48.1 [14.1] 4.4	54.0 [15.8] 43.1 [12.6] 4.4
	100 [37.8]	Total BTUH [kW] Sens BTUH [kW] Power	63.0 [18.5] 40.5 [11.9] 4.7	61.8 [18.1] 37.4 [11.0] 4.7	60.1 [17.6] 33.1 [9.7] 4.6	58.9 [17.3] 46.6 [13.7] 4.7	57.8 [16.9] 43.3 [12.7] 4.7	56.1 [16.4] 38.5 [11.3] 4.6	55.0 [16.1] 50.8 [14.9] 4.7	53.9 [15.8] 47.3 [13.9] 4.6	52.4 [15.4] 42.4 [12.4] 4.6
	105 [40.6]	Total BTUH [kW] Sens BTUH [kW] Power	61.3 [18.0] 39.8 [11.7] 5.0	60.2 [17.6] 36.8 [10.8] 4.9	58.4 [17.1] 32.4 [9.5] 4.9	57.2 [16.8] 45.7 [13.4] 5.0	56.1 [16.4] 42.5 [12.5] 4.9	54.5 [16.0] 37.9 [11.1] 4.8	53.3 [15.6] 49.9 [14.6] 4.9	52.3 [15.3] 46.6 [13.7] 4.9	50.8 [14.9] 41.8 [12.2] 4.8
	110 [43.3]	Total BTUH [kW] Sens BTUH [kW] Power	59.6 [17.5] 38.9 [11.4] 5.2	58.5 [17.1] 36.0 [10.5] 5.2	56.8 [16.6] 31.8 [9.3] 5.1	55.4 [16.2] 44.9 [13.2] 5.2	54.4 [15.9] 41.8 [12.2] 5.2	52.8 [15.5] 37.2 [10.9] 5.1	51.5 [15.1] 49.1 [14.4] 5.2	50.6 [14.8] 45.9 [13.4] 5.1	49.1 [14.4] 41.1 [12.0] 5.1
	115 [46.1]	Total BTUH [kW] Sens BTUH [kW] Power	57.9 [17.0] 38.1 [11.2] 5.5	56.8 [16.6] 35.2 [10.3] 5.5	55.1 [16.1] 31.0 [9.1] 5.4	53.7 [15.7] 44.1 [12.9] 5.5	52.7 [15.4] 41.0 [12.0] 5.4	51.2 [15.0] 36.6 [10.7] 5.3	49.8 [14.6] 48.3 [14.2] 5.4	48.9 [14.3] 45.1 [13.2] 5.4	47.5 [13.9] 40.5 [11.9] 5.3

DR —Depression ratio  
dbE —Entering air dry bulb  
wbE—Entering air wet bulb

Total —Total capacity x 1000 BTUH  
Sens —Sensible capacity x 1000 BTUH  
Power —kW input

**NOTES:**

① When the entering air dry bulb is other than 80°F [27°C], adjust the sensible capacity from the table by adding [1.10 x CFM x (1 – DR) x (dbE – 80)].

## HEATING PERFORMANCE DATA—RHPXZR060AJT

IDB		60°F [15.5°C]			70°F [21.1°C]			80°F [26.7°C]			
CFM [L/s]		2100 [991]	1900 [897]	1600 [755]	2100 [991]	1900 [897]	1600 [755]	2100 [991]	1900 [897]	1600 [755]	
OUTDOOR DRY BULB TEMPERATURE °F [°C]	0 [-17.8]	Total BTUH [kW] Power	25.0 [7.3] 2.9	24.8 [7.3] 3.0	24.5 [7.2] 3.0	23.7 [6.9] 3.3	23.5 [6.9] 3.3	23.2 [6.8] 3.4	22.3 [6.5] 3.7	22.2 [6.5] 3.7	21.9 [6.4] 3.8
	5 [-15]	Total BTUH [kW] Power	28.2 [8.3] 3.0	28.0 [8.2] 3.0	27.7 [8.1] 3.1	26.9 [7.9] 3.4	26.7 [7.8] 3.4	26.4 [7.7] 3.5	25.6 [7.5] 3.7	25.4 [7.4] 3.8	25.1 [7.4] 3.9
	10 [-12.2]	Total BTUH [kW] Power	31.5 [9.2] 3.0	31.2 [9.1] 3.1	30.9 [9.1] 3.1	30.1 [8.8] 3.4	29.9 [8.8] 3.5	29.6 [8.7] 3.5	28.8 [8.4] 3.8	28.6 [8.4] 3.8	28.2 [8.3] 3.9
	15 [-9.4]	Total BTUH [kW] Power	34.7 [10.2] 3.1	34.4 [10.1] 3.1	34.0 [10.0] 3.2	33.3 [9.8] 3.5	33.1 [9.7] 3.5	32.7 [9.6] 3.6	32.0 [9.4] 3.8	31.8 [9.3] 3.9	31.4 [9.2] 4.0
	20 [-6.7]	Total BTUH [kW] Power	37.9 [11.1] 3.1	37.6 [11.0] 3.2	37.2 [10.9] 3.2	36.6 [10.7] 3.5	36.3 [10.6] 3.6	35.9 [10.5] 3.6	35.2 [10.3] 3.9	35.0 [10.3] 4.0	34.6 [10.1] 4.0
	25 [-3.9]	Total BTUH [kW] Power	41.1 [12.0] 3.2	40.8 [12.0] 3.2	40.3 [11.8] 3.3	39.8 [11.7] 3.6	39.5 [11.6] 3.6	39.0 [11.4] 3.7	38.4 [11.3] 4.0	38.2 [11.2] 4.0	37.7 [11.0] 4.1
	30 [-1.1]	Total BTUH [kW] Power	44.3 [13.0] 3.3	44.0 [12.9] 3.3	43.5 [12.7] 3.4	43.0 [12.6] 3.6	42.7 [12.5] 3.7	42.2 [12.4] 3.8	41.7 [12.2] 4.0	41.3 [12.1] 4.1	40.9 [12.0] 4.1
	35 [1.7]	Total BTUH [kW] Power	47.6 [13.9] 3.3	47.2 [13.8] 3.4	46.7 [13.7] 3.4	46.2 [13.5] 3.7	45.9 [13.4] 3.7	45.4 [13.3] 3.8	44.9 [13.2] 4.1	44.5 [13.0] 4.1	44.0 [12.9] 4.2
	40 [4.4]	Total BTUH [kW] Power	50.8 [14.9] 3.4	50.4 [14.8] 3.4	49.8 [14.6] 3.5	49.4 [14.5] 3.7	49.1 [14.4] 3.8	48.5 [14.2] 3.9	48.1 [14.1] 4.1	47.7 [14.0] 4.2	47.2 [13.8] 4.3
	45 [7.2]	Total BTUH [kW] Power	54.0 [15.8] 3.4	53.6 [15.7] 3.5	53.0 [15.5] 3.5	52.7 [15.4] 3.8	52.3 [15.3] 3.8	51.7 [15.1] 3.9	51.3 [15.0] 4.2	50.9 [14.9] 4.2	50.4 [14.8] 4.3
50 [10]	Total BTUH [kW] Power	57.2 [16.8] 3.5	56.8 [16.6] 3.5	56.2 [16.5] 3.6	55.9 [16.4] 3.9	55.5 [16.3] 3.9	54.8 [16.1] 4.0	54.5 [16.0] 4.2	54.1 [15.9] 4.3	53.5 [15.7] 4.4	

IDB—Indoor air dry bulb

[ ] Designates Metric Conversions

# INDOOR AIRFLOW PERFORMANCE—RHPAZR—208/230 VOLTS

Nominal Cooling Capacity Tons [kW]	Manufacturer Recommended Heat Pump Airflow (Min/Max)	Blower Size/ Motor HP [W] & # of Speeds	Motor Speed	External Static Pressure - Inches W.C. [kPa] (Side Discharge-Dry Coil)										
				0.1 [.02]	0.2 [.05]	0.3 [.07]	0.4 [.10]	0.5 [.12]	0.6 [.15]	0.7 [.17]	0.8 [.20]	0.9 [.23]	1.0 [.25]	
2.0 [7.03]	700 CFM / 900 CFM  10 x 9 Blower 1/3 HP [249W] Ensite Air	Tap 1 Fan only	CFM [l/s]	1003 [473]	942 [445]	890 [420]	830 [392]	784 [370]	732 [345]	678 [320]	612 [289]	573 [270]	526 [248]	
			RPM	722	779	826	879	925	974	1020	1059	1087	1119	
			Watts	134	143	150	158	164	172	179	185	190	194	
		Tap 2 Heater kit	CFM [l/s]	1021 [482]	975 [460]	911 [430]	850 [401]	802 [379]	753 [355]	714 [337]	657 [310]	600 [283]	549 [259]	526 [248]
			RPM	736	784	841	893	935	979	1022	1063	1093	1125	
			Watts	141	148	159	166	174	182	187	194	199	204	
		Tap 3 HP Medium	CFM [l/s]	1119 [528]	1079 [509]	1026 [484]	981 [463]	926 [437]	876 [413]	819 [387]	782 [369]	739 [349]	661 [312]	661 [312]
			RPM	785	822	866	914	957	1004	1048	1081	1114	1136	
			Watts	178	185	194	202	210	219	227	233	238	232	
		Tap 4 HP Low	CFM [l/s]	923 [436]	870 [411]	817 [386]	763 [360]	703 [332]	640 [302]	586 [277]	530 [250]	484 [228]	453 [214]	453 [214]
			RPM	701	750	797	845	898	947	986	1025	1059	1081	
			Watts	117	123	129	136	143	150	156	160	166	169	
Tap 5 HP High	CFM [l/s]	1344 [634]	1305 [616]	1267 [598]	1230 [580]	1178 [556]	1121 [529]	1054 [497]	921 [435]	824 [389]	692 [327]	692 [327]		
	RPM	906	933	976	1005	1043	1087	1111	1132	1144	1155			
	Watts	286	294	305	313	322	329	316	292	267	247			
2.5 [8.79]	875 CFM / 1125 CFM  10 x 9 Blower 1/2 HP [373W] Ensite Air	Tap 1 Fan only	CFM [l/s]	1037 [489]	985 [465]	939 [443]	867 [409]	783 [370]	721 [340]	674 [318]	613 [289]	554 [261]	513 [242]	
			RPM	669	718	762	822	880	921	955	1009	1047	1081	
			Watts	117	125	132	141	150	157	160	169	174	179	
		Tap 2 Heater kit	CFM [l/s]	1281 [605]	1235 [583]	1197 [565]	1150 [543]	1114 [526]	1063 [502]	995 [470]	928 [438]	883 [417]	843 [398]	843 [398]
			RPM	788	827	867	907	940	988	1037	1086	1118	1139	
			Watts	200	208	215	225	233	243	253	265	271	275	
		Tap 3 HP Medium	CFM [l/s]	1356 [640]	1314 [620]	1274 [601]	1241 [586]	1201 [567]	1157 [546]	1102 [520]	1019 [481]	941 [444]	869 [410]	869 [410]
			RPM	825	862	902	936	970	1012	1052	1109	1138	1150	
			Watts	233	241	250	259	267	277	286	299	298	287	
		Tap 4 HP Low	CFM [l/s]	1199 [566]	1156 [546]	1120 [529]	1088 [513]	1037 [489]	977 [461]	885 [418]	833 [393]	792 [374]	751 [354]	751 [354]
			RPM	762	804	839	871	916	965	1024	1061	1093	1121	
			Watts	173	179	188	195	203	213	224	232	239	244	
Tap 5 HP High	CFM [l/s]	1489 [703]	1454 [686]	1415 [668]	1383 [653]	1345 [635]	1309 [618]	1269 [599]	1195 [564]	989 [467]	889 [420]	889 [420]		
	RPM	886	921	957	989	1025	1057	1093	1123	1150	1159			
	Watts	298	308	318	327	337	346	355	353	313	296			

NOTE: Grey cells indicate airflow outside of manufacturers recommendation.  
Do not connect wiring to unspecified speed taps.

DOWN DISCHARGE PRESSURE DROP (ADD TO EXTERNAL STATIC PRESSURE)			
CFM [L/s]	600 [283]	800 [378]	1000 [472]
Pressure Drop—Inches W.C. [kPa]	0	.02 [.005]	.05 [.012]
		1200 [566]	1400 [661]
		1600 [755]	1800 [849]
		.07 [.017]	.1 [.025]
		.12 [.030]	.15 [.037]
		2000 [944]	.17 [.042]

[ ] Designates Metric Conversions

# INDOOR AIRFLOW PERFORMANCE—RHPAZR—208/230 VOLTS

Nominal Cooling Capacity Tons [KW]	Manufacturer Recommended Heat Pump Airflow (Min/Max)	Blower Size/Motor HP [W] & # of Speeds	Motor Speed	External Static Pressure - Inches W.C. [kPa] (Side Discharge-Dry Coil)											
				0.1 [.02]	0.2 [.05]	0.3 [.07]	0.4 [.10]	0.5 [.12]	0.6 [.15]	0.7 [.17]	0.8 [.20]	0.9 [.23]	1.0 [.25]		
3.0 [10.55]	1050 CFM / 1350 CFM	12 x 9T Blower 1/2 HP [373W] Ensite Air	Tap 1 Fan only	CFM [l/s]	992 [468]	908 [429]	797 [376]	718 [339]	579 [273]	501 [236]	422 [199]	351 [166]	313 [148]	295 [139]	
				RPM	591	623	693	733	769	814	844	866	879	925	
				Watts	109	111	121	127	131	138	143	147	149	156	
			Tap 2 Heater kit	CFM [l/s]	1202 [567]	1155 [545]	1102 [520]	1029 [486]	943 [445]	892 [421]	811 [383]	745 [352]	654 [309]	596 [281]	596 [281]
				RPM	686	717	751	805	856	884	918	948	991	1013	
				Watts	178	183	192	204	215	220	227	235	243	249	
			Tap 3 HP Medium	CFM [l/s]	1452 [685]	1420 [670]	1373 [648]	1335 [630]	1292 [610]	1199 [566]	1002	1084 [512]	1024 [483]	967 [456]	967 [456]
				RPM	799	822	852	875	904	970	1002	1032	1061	1090	
				Watts	295	302	311	318	327	347	358	367	375	385	
			Tap 4 HP Low	CFM [l/s]	1514 [715]	1469 [693]	1435 [677]	1391 [656]	1347 [636]	1271 [600]	1210 [571]	1143 [539]	1095 [517]	1029 [486]	1029 [486]
				RPM	821	847	870	900	924	973	1018	1052	1076	1097	
				Watts	328	335	343	352	360	377	391	401	410	409	
			Tap 5 HP High	CFM [l/s]	1573 [742]	1532 [723]	1497 [707]	1453 [686]	1419 [670]	1378 [650]	1287 [607]	1218 [575]	1147 [541]	1058 [499]	1058 [499]
				RPM	852	874	899	925	948	972	1040	1074	1093	1108	
				Watts	369	377	385	395	402	411	433	445	440	429	

NOTE: Grey cells indicate airflow outside of manufacturers recommendation.  
Do not connect wiring to unspecified speed taps.

DOWN DISCHARGE PRESSURE DROP (ADD TO EXTERNAL STATIC PRESSURE)					
CFM [L/s]	600 [283]	1000 [472]	1400 [661]	1800 [849]	2000 [944]
Pressure Drop—Inches W.C. [kPa]	0	.05 [.012]	.1 [.025]	.15 [.037]	.17 [.042]

[ ] Designates Metric Conversions



# INDOOR AIRFLOW PERFORMANCE -- RHPXZR -- 208/230 VOLTS

Nominal Cooling Capacity Tons [kW]	Manufacturer Recommended Heat Pump Airflow (Min/Max)	Blower Size/ Motor HP [W] & # of Speeds	Motor Speed	External Static Pressure - Inches W.C. [kPa] (Side Discharge-Dry Coil)										
				0.1 [.02]	0.2 [.05]	0.3 [.07]	0.4 [.10]	0.5 [.12]	0.6 [.15]	0.7 [.17]	0.8 [.20]	0.9 [.23]	1.0 [.25]	
3.5 [12.31]	1225 CFM / 1575 CFM	12 x 9T Blower 3/4 HP [559W] Ensite Air	Tap1 Fan only	CFM [l/s]	1400 [661]	1202 [567]	1057 [499]	1013 [478]	900 [425]	767 [362]	721 [340]	673 [318]	577 [272]	513 [242]
				RPM	579	588	623	662	737	812	835	865	929	955
			Watts	194	163	154	162	177	193	199	205	218	224	224
			Tap 2 Heater kit	CFM [l/s]	1400 [661]	1202 [567]	1057 [499]	1013 [478]	900 [425]	767 [362]	721 [340]	673 [318]	577 [272]	513 [242]
				RPM	579	588	623	662	737	812	835	865	929	955
			Watts	194	163	154	162	177	193	199	205	218	224	224
			Tap 3 HP Medium	CFM [l/s]	1712 [808]	1682 [794]	1636 [772]	1596 [753]	1545 [729]	1490 [703]	1444 [681]	1405 [663]	1371 [647]	1338 [631]
				RPM	667	697	741	777	818	863	903	935	961	982
			Watts	327	339	356	371	386	405	420	433	444	451	451
			Tap 4 HP Low	CFM [l/s]	1493 [705]	1453 [686]	1413 [667]	1342 [633]	1294 [611]	1248 [589]	1201 [567]	1104 [521]	970 [458]	926 [437]
RPM	602	643		682	739	779	818	853	916	993	1018			
Watts	229	242	253	271	284	296	308	327	352	360	360			
Tap 5 HP High	CFM [l/s]	1753 [827]	1717 [810]	1679 [792]	1638 [773]	1590 [750]	1543 [728]	1492 [704]	1455 [687]	1417 [669]	1390 [656]			
	RPM	684	716	752	781	824	867	904	940	969	988			
Watts	350	364	380	392	410	427	440	455	469	478	478			
4.0 [14.07]	1400 CFM / 1800 CFM	12 x 9T Blower 3/4 HP [559W] Ensite Air	Tap1 Fan only	CFM [l/s]	1400 [661]	1202 [567]	1057 [499]	1013 [478]	900 [425]	767 [362]	721 [340]	673 [318]	577 [272]	513 [242]
				RPM	579	588	623	662	737	812	835	865	929	955
			Watts	194	163	154	162	177	193	199	205	218	224	224
			Tap 2 Heater kit	CFM [l/s]	1400 [661]	1202 [567]	1057 [499]	1013 [478]	900 [425]	767 [362]	721 [340]	673 [318]	577 [272]	513 [242]
				RPM	579	588	623	662	737	812	835	865	929	955
			Watts	194	163	154	162	177	193	199	205	218	224	224
			Tap 3 HP Medium	CFM [l/s]	1873 [884]	1845 [871]	1805 [852]	1754 [828]	1717 [810]	1673 [790]	1637 [773]	1599 [755]	1555 [734]	1502 [709]
				RPM	719	744	776	817	850	885	924	960	992	1029
			Watts	422	434	446	465	481	498	517	535	549	567	567
			Tap 4 HP Low	CFM [l/s]	1753 [827]	1717 [810]	1679 [792]	1638 [773]	1590 [750]	1543 [728]	1492 [704]	1455 [687]	1417 [669]	1390 [656]
RPM	684	716		752	781	824	867	904	940	969	988			
Watts	350	364	380	392	410	427	440	455	469	478	478			
Tap 5 HP High	CFM [l/s]	1962 [926]	1929 [910]	1886 [890]	1850 [873]	1814 [856]	1783 [841]	1752 [827]	1702 [803]	1674 [790]	1629 [769]			
	RPM	755	775	806	839	867	902	933	980	1009	1048			
Watts	487	498	512	529	544	561	579	604	619	644	644			

NOTE: Grey cells indicate airflow outside of manufacturers recommendation.  
Do not connect wiring to unspecified speed taps.

### DOWN DISCHARGE PRESSURE DROP (ADD TO SIDE DISCHARGE EXTERNAL STATIC PRESSURE)

CFM [L/s]	800 [378]	1000 [472]	1200 [566]	1400 [661]	1600 [755]	1800 [849]	2000 [944]	2200 [1038]
Pressure Drop--Inches W.C. [kPa]	.02 [.005]	.05 [.012]	.07 [.017]	.1 [.025]	.12 [.030]	.15 [.037]	.17 [.042]	0.2 [.05]

[ ] Designates Metric Conversions

# INDOOR AIRFLOW PERFORMANCE—230 VOLTS

Nominal Cooling Capacity Tons [kW]	Manufacturer Recommended Heat Pump Airflow (Min/Max)	Blower Size/ Motor HP [W] & # of Speeds	Motor Speed	External Static Pressure - Inches W.C. [kPa] (Side Discharge-Dry Coil)										
				0.1 [.02]	0.2 [.05]	0.3 [.07]	0.4 [.10]	0.5 [.12]	0.6 [.15]	0.7 [.17]	0.8 [.20]	0.9 [.23]	1.0 [.25]	
5.0 [17.58]	1750 CFM / 2250 CFM	12 x 9T Blower 1 HP [746W] Ensite Air	Tap 1 Fan only	CFM [l/s]	1396 [659]	1250 [590]	1199 [566]	1146 [541]	1095 [517]	1037 [489]	857 [404]	785 [370]	745 [352]	698 [329]
				RPM	585	592	634	676	722	759	868	904	929	968
				Watts	186	163	173	182	193	201	227	235	241	250
			Tap 2 Heater kit	CFM [l/s]	1396 [659]	1250 [590]	1199 [566]	1146 [541]	1095 [517]	1037 [489]	857 [404]	785 [370]	745 [352]	698 [329]
				RPM	585	592	634	676	722	759	868	904	929	968
				Watts	186	163	173	182	193	201	227	235	241	250
			Tap 3 HP Medium	CFM [l/s]	1468 [693]	1443 [681]	1389 [656]	1344 [634]	1291 [609]	1251 [590]	1205 [569]	1086 [513]	975 [460]	915 [432]
				RPM	609	638	683	722	767	796	831	913	977	1009
				Watts	213	223	235	246	260	268	279	303	323	332
			Tap 4 HP Low	CFM [l/s]	2095 [989]	2071 [977]	2043 [964]	2018 [952]	1981 [935]	1945 [918]	1913 [903]	1870 [883]	1839 [868]	1800 [850]
				RPM	808	829	856	877	911	935	970	1002	1029	1069
				Watts	571	581	598	609	628	641	663	678	700	723
			Tap 5 HP High	CFM [l/s]	2262 [1068]	2245 [1060]	2218 [1047]	2190 [1034]	2158 [1018]	2135 [1008]	2100 [991]	2068 [976]	2002 [945]	1940 [916]
				RPM	867	880	897	936	956	985	1017	1043	1076	1094
				Watts	736	748	760	784	797	818	841	858	865	846

NOTE: Grey cells indicate airflow outside of manufacturers recommendation.  
Do not connect wiring to unspecified speed taps.

DOWN DISCHARGE PRESSURE DROP (ADD TO SIDE DISCHARGE EXTERNAL STATIC PRESSURE)			
CFM [L/s]	800 [378]	1000 [472]	1200 [566]
Pressure Drop—Inches W.C. [kPa]	.02 [.005]	.05 [.012]	.07 [.017]
		1400 [661]	1600 [755]
		.1 [.025]	.12 [.030]
		1800 [849]	2000 [944]
		.15 [.037]	.17 [.042]
		2200 [1038]	0.2 [.05]

[ ] Designates Metric Conversions

ELECTRICAL DATA – RHP(A/X)ZR SERIES							
		024AJT	030AJT	036AJT	042AJT	048AJT	060AJT
Unit Information	Unit Operating Voltage Range	187-253	187-253	187-253	187-253	187-253	187-253
	Volts	208/230	208/230	208/230	208/230	208/230	208/230
	Phase	1	1	1	1	1	1
	Hz	60	60	60	60	60	60
	Minimum Circuit Ampacity	17	21	24	28	34	40
	Minimum Overcurrent Protection Device Size	20	25	30	35	40	50
Compressor Motor	Maximum Overcurrent Protection Device Size	25	30	35	40	50	60
	No.	1	1	1	1	1	1
	Volts	208/230	208/230	208/230	208/230	208/230	208/230
	Phase	1	1	1	1	1	1
	RPM	3500	3500	3500	3500	3500	3500
	HP, Compressor 1						
	Amps (RLA), Comp. 1	10.1	11.7	14.3	15.9	20.8	23.5
	Amps (LRA), Comp. 1	48.4	71.3	83.1	95.2	102.4	118
	HP, Compressor 2						
Condenser Motor	Amps (RLA), Comp. 2						
	Amps (LRA), Comp. 2						
	No.	1	1	1	1	1	1
	Volts	208/230	208/230	208/230	208/230	208/230	208/230
	Phase	1	1	1	1	1	1
	HP	1/3	1/3	1/3	1/3	1/3	1/2
Evaporator Fan	Amps (FLA, each)	1.5	2	2	2	2	2.3
	Amps (LRA, each)	3	3.9	3.9	3.9	3.9	5.5
	No.	1	1	1	1	1	1
	Volts	208/230	208/230	208/230	208/230	208/230	208/230
	Phase	1	1	1	1	1	1
Evaporator Fan	HP	1/3	1/2	1/2	3/4	3/4	1
	Amps (FLA, each)	2.8	4.1	4.1	6	6	7.6
	Amps (LRA, each)						

1. Horsepower Per Compressor.
2. Amp Draw Per Motor. Multiply Value By Number of Motors to Determine Total Amps.

<b>Electric Heater Kit Factory Installed Options*</b>	<b>Unit Model Application</b>
RXQJ-A10J (208-240 volt, 1-ph, 10kW)	RHPAZR024/030/036
RXQJ-A15J (208-240 volt, 1-ph, 15kW)	RHPAZR036 RHPXZR042
RXQJ-B15J (208-240 volt, 1-ph, 15kW)	RHPXZR048/060

\*Further kits for field installation on following pages.

## **WARNING**

**ONLY ELECTRIC HEATER KITS SUPPLIED BY THIS MANUFACTURER AS DESCRIBED IN THIS PUBLICATION HAVE BEEN DESIGNED, TESTED, AND EVALUATED BY A NATIONALLY RECOGNIZED SAFETY TESTING AGENCY FOR USE WITH THIS UNIT. USE OF ANY OTHER MANUFACTURED ELECTRIC HEATERS INSTALLED WITHIN THIS UNIT MAY CAUSE HAZARDOUS CONDITIONS RESULTING IN PROPERTY DAMAGE, FIRE, BODILY INJURY OR DEATH.**

**208/240 VOLT, SINGLE PHASE, 60 Hz, AUXILIARY ELECTRIC HEATER KITS CHARACTERISTICS AND APPLICATION**

RUUD Model Number RHP(A/X)ZR		Single Power Supply For Both Unit and Heater Kit				Separate Power Supply for Both Unit and Heater Kit			
		Heater Kit		Air Conditioner		Heater Kit		Air Conditioner	
	RXQJ- Heater Kit Nominal KW	Rated Heater kW @ 208/240 V	Heater Amp. @ 208/240 V	Unit Min. Ckt. Ampacity @ 208/240 V	Over Current Protective Device Size Min./Max	Min. Ckt. Ampacity 208/240V	Max. Fuse Size 208/240	Min. Ckt. Ampacity 208/240 V	Over Current Protective Device Size Min./Max
024AJT000NA HEATER KW	NONE	—	—	17/17	25/25	—	—	17/17	25/25
	A05J	3.6/4.8	17.3/20	39/42	40/45	22/25	25/25	17/17	25/25
	A08J	5.7/7.6	27.4/31.6	52/57	60/60	35/40	35/40	17/17	25/25
	A10J	7.2/9.6	34.6/40	61/67	70/70	44/50	45/50	17/17	25/25
030AJT000NA HEATER KW	NONE	—	—	21/21	30/30	—	—	21/21	30/30
	A05J	3.6/4.8	17.3/20	43/46	45/50	22/25	25/25	21/21	30/30
	A08J	5.7/7.6	27.4/31.6	55/61	60/70	35/40	35/40	21/21	30/30
	A10J	7.2/9.6	34.6/40	64/71	70/80	44/50	45/50	21/21	30/30
036AJT000NA HEATER KW	NONE	—	—	24/24	35/35	—	—	24/24	35/35
	A05J	3.6/4.8	17.3/20	46/49	50/50	22/25	25/25	24/24	35/35
	A08J	5.7/7.6	27.4/31.6	59/64	60/70	35/40	35/40	24/24	35/35
	A10J	7.2/9.6	34.6/40	68/74	70/80	44/50	45/50	24/24	35/35
042AJT000NA HEATER KW	A15J	10.8/14.4	51.9/60	89/99	90/100	65/75	70/80	24/24	35/35
	NONE	—	—	28/28	40/40	—	—	28/28	40/40
	A05J	3.6/4.8	17.3/20	50/53	60/60	22/25	25/25	28/28	40/40
	A08J	5.7/7.6	27.4/31.6	63/68	70/70	35/40	35/40	28/28	40/40
048AJT000NA HEATER KW	A10J	7.2/9.6	34.6/40	72/78	80/80	44/50	45/50	28/28	40/40
	A15J	10.8/14.4	51.9/60	93/103	100/110	65/75	70/80	28/28	40/40
	NONE	—	—	34/34	50/50	—	—	34/34	50/50
	A05J	3.6/4.8	17.3/20	56/59	70/70	22/25	25/25	34/34	50/50
060AJT000NA HEATER KW	A08J	5.7/7.6	27.4/31.6	69/74	80/80	35/40	35/40	34/34	50/50
	B10J	7.2/9.6	34.6/40	78/84	80/90	44/50	45/50	34/34	50/50
	B15J	10.8/14.4	51.9/60	99/109	100/110	65/75	70/80	34/34	50/50
	NONE	—	—	40/40	60/60	—	—	40/40	60/60
060AJT000NA HEATER KW	A05J	3.6/4.8	17.3/20	61/65	80/80	22/25	25/25	40/40	60/60
	A08J	5.7/7.6	27.4/31.6	74/79	90/90	35/40	35/40	40/40	60/60
	B10J	7.2/9.6	34.6/40	83/90	90/100	44/50	45/50	40/40	60/60
	B15J	10.8/14.4	51.9/60	105/115	110/125	65/75	70/80	40/40	60/60

# DIMENSIONAL DATA

## RHPA Cabinet

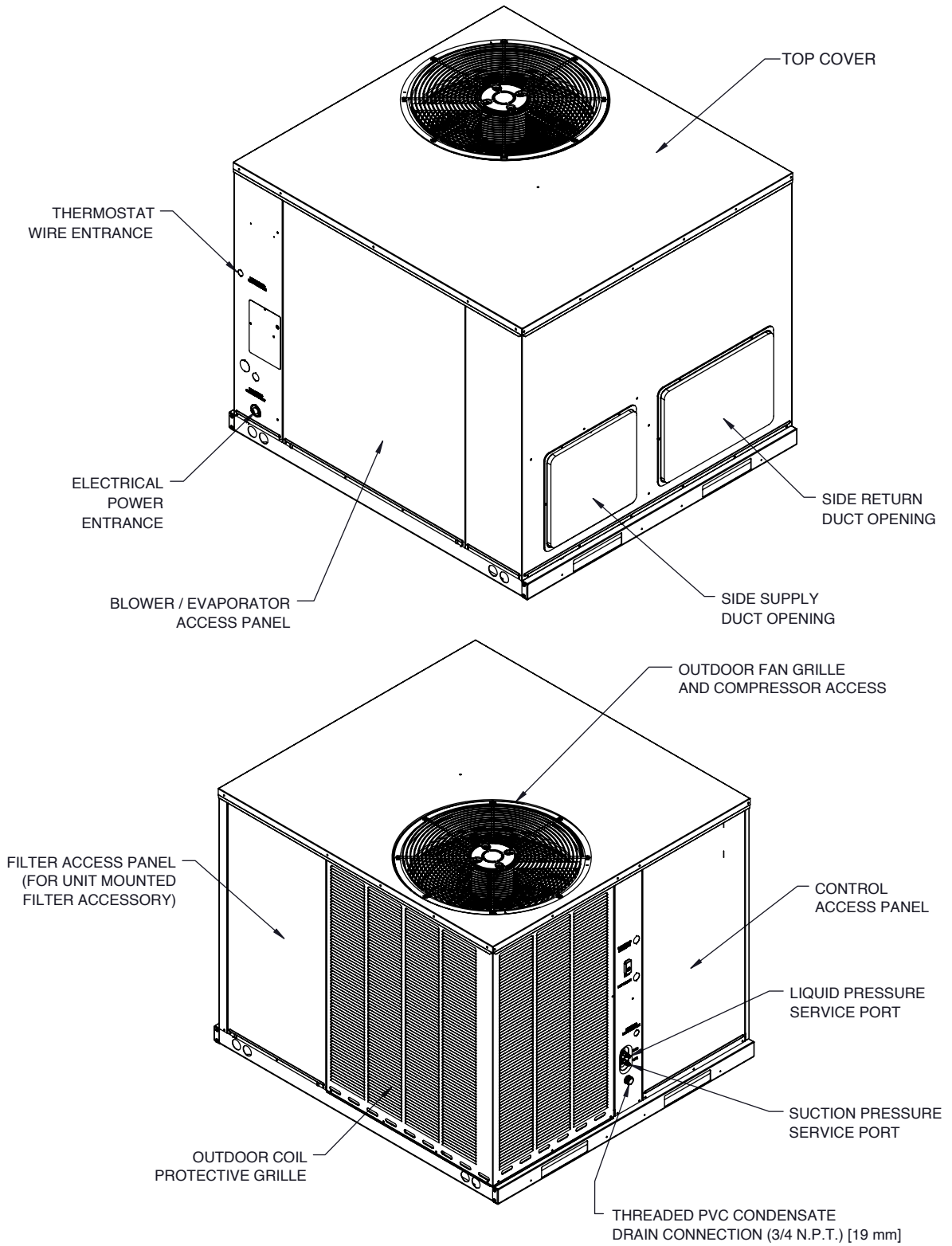
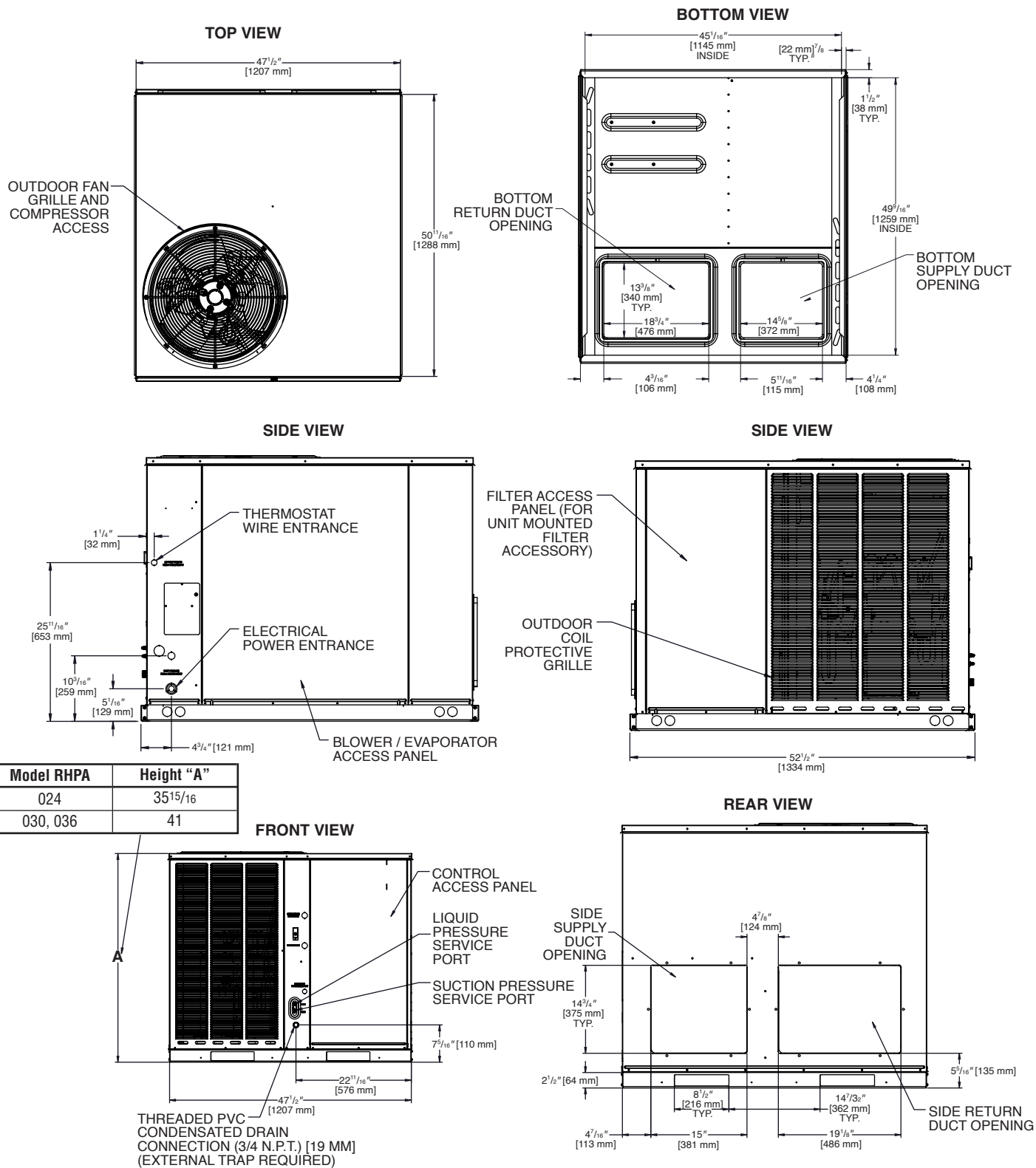

Illustration  
ST-A1333-01

[ ] Designates Metric Conversions

# DIMENSIONAL DATA

## RHPA Cabinet



Model RHPA	Height "A"
024	35 <sup>15</sup> / <sub>16</sub>
030, 036	41

[ ] Designates Metric Conversions

Illustration  
ST-A1333-02

# DIMENSIONAL DATA

## RHPX Cabinet

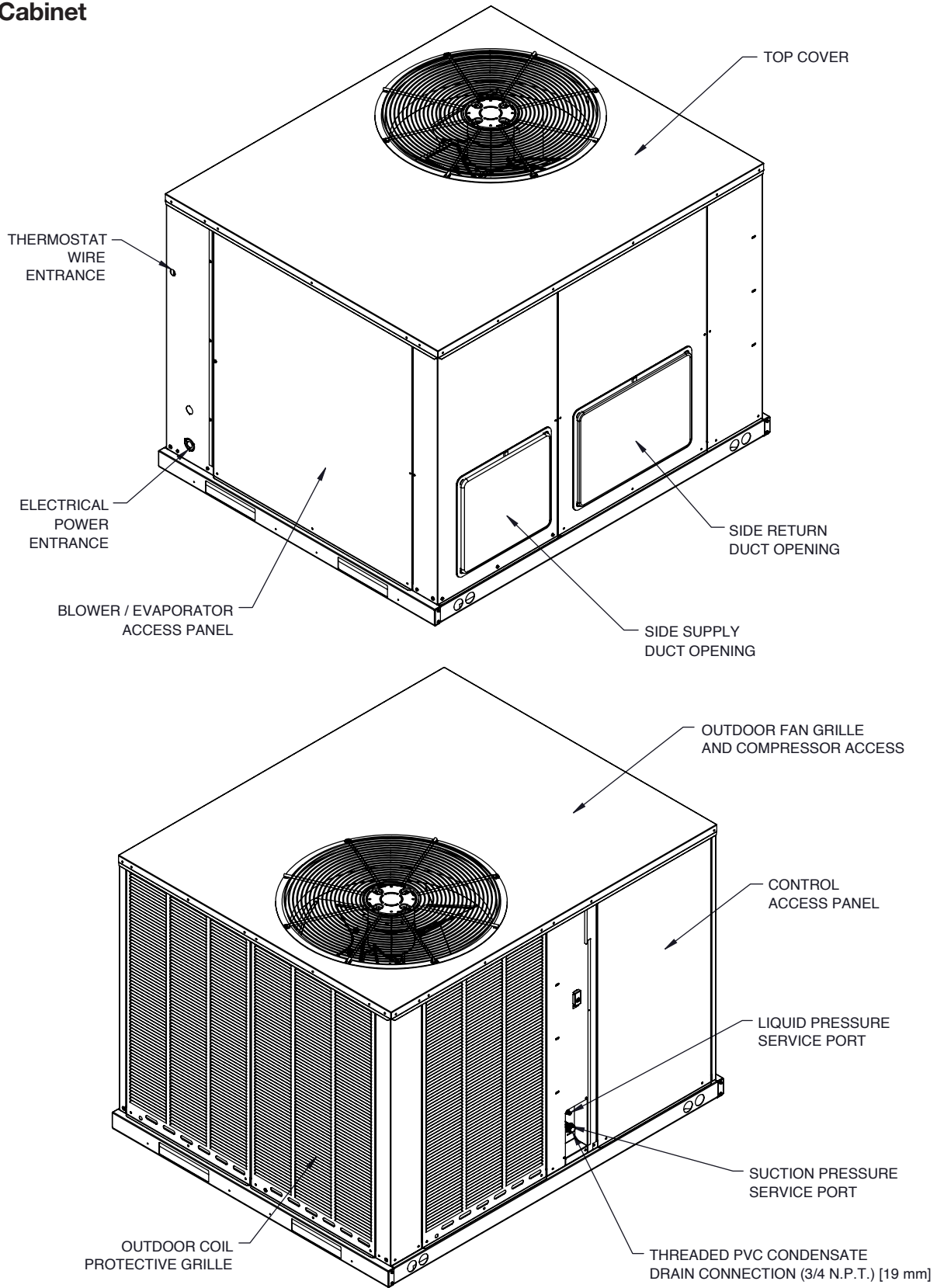

[ ] Designates Metric Conversions

Illustration  
ST-A1334-01



# DIMENSIONAL DATA

## RHPX Cabinet

TOP VIEW

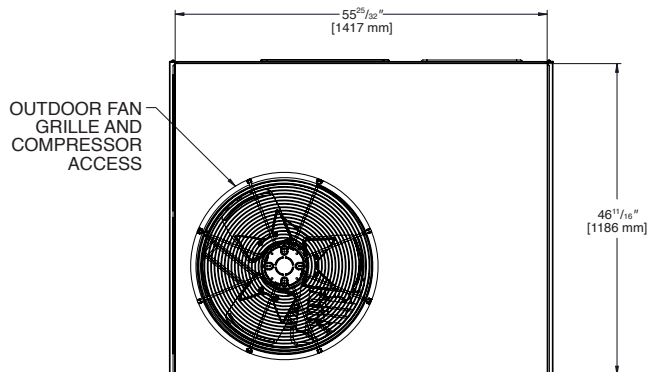

BOTTOM VIEW

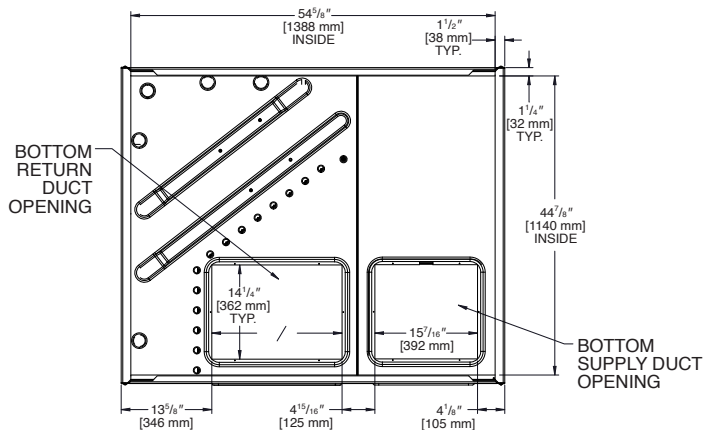

SIDE VIEW

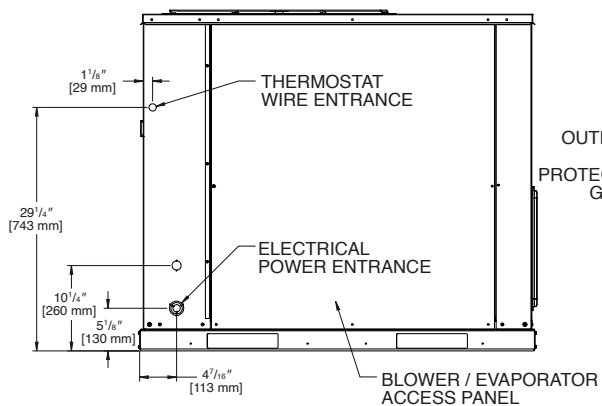

SIDE VIEW

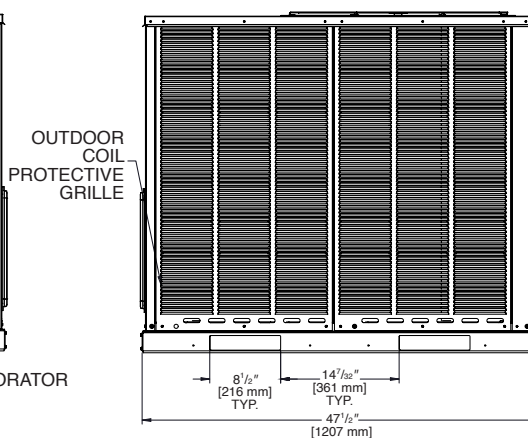

FRONT VIEW

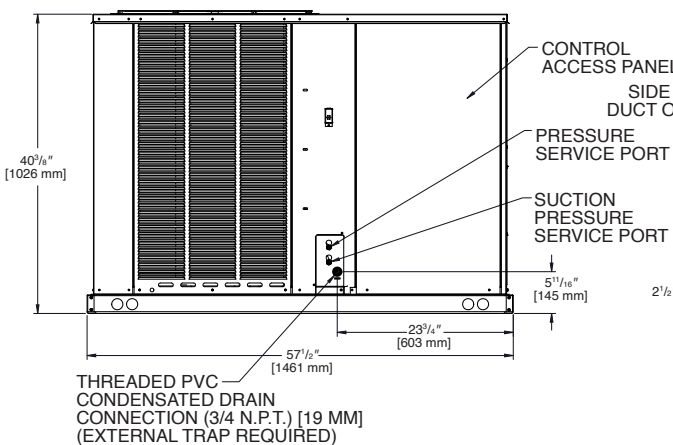

REAR VIEW

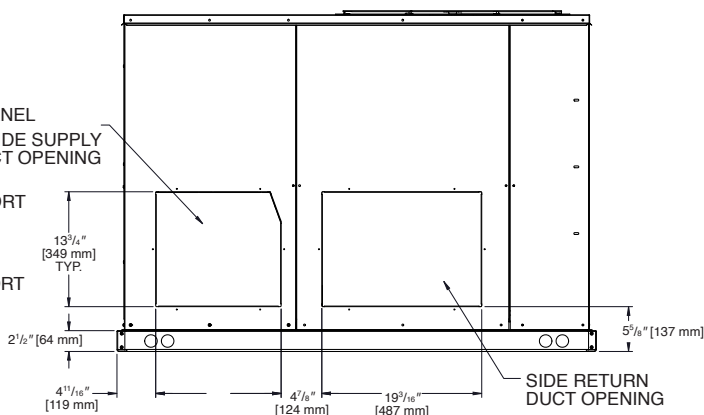
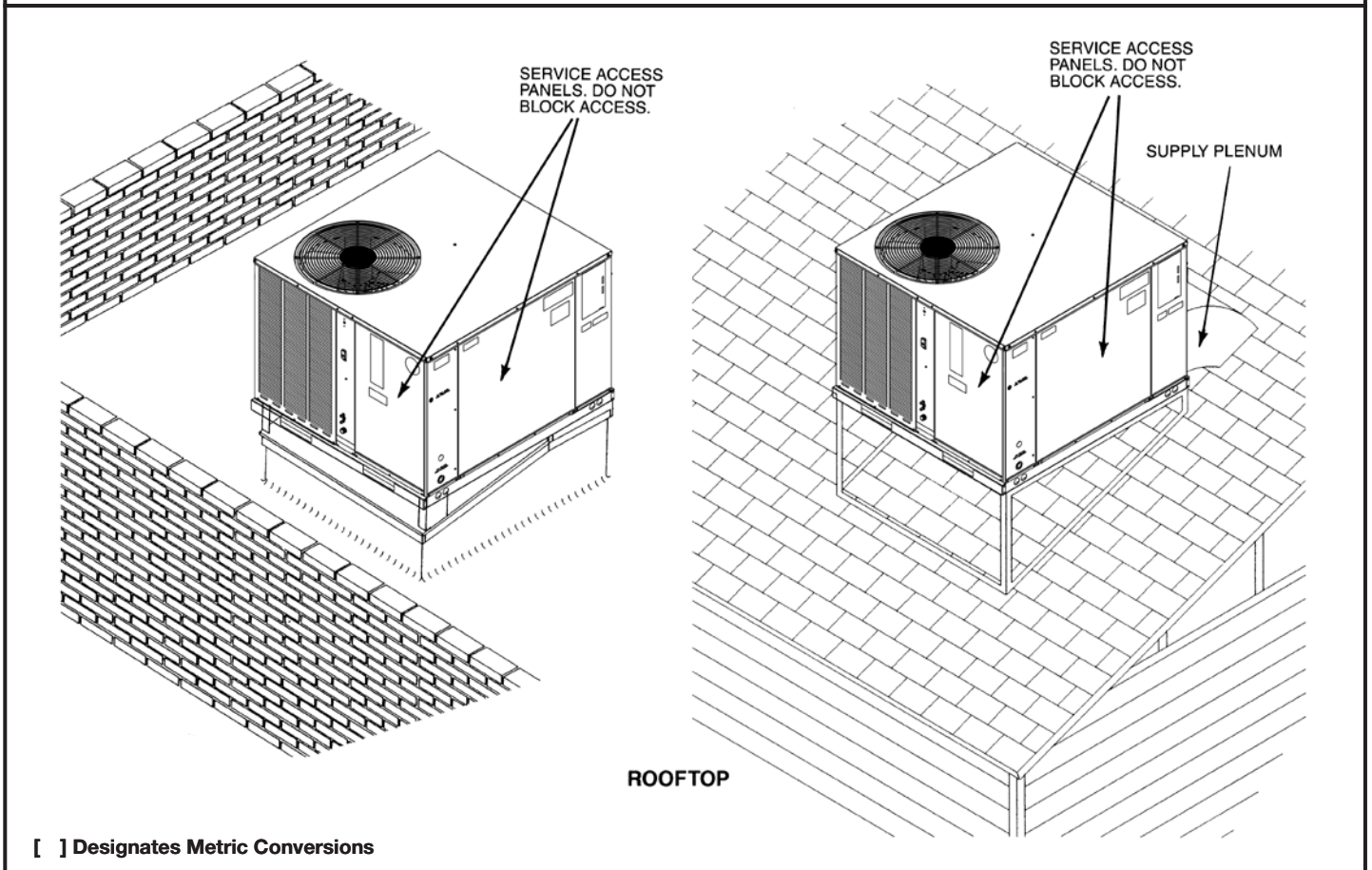
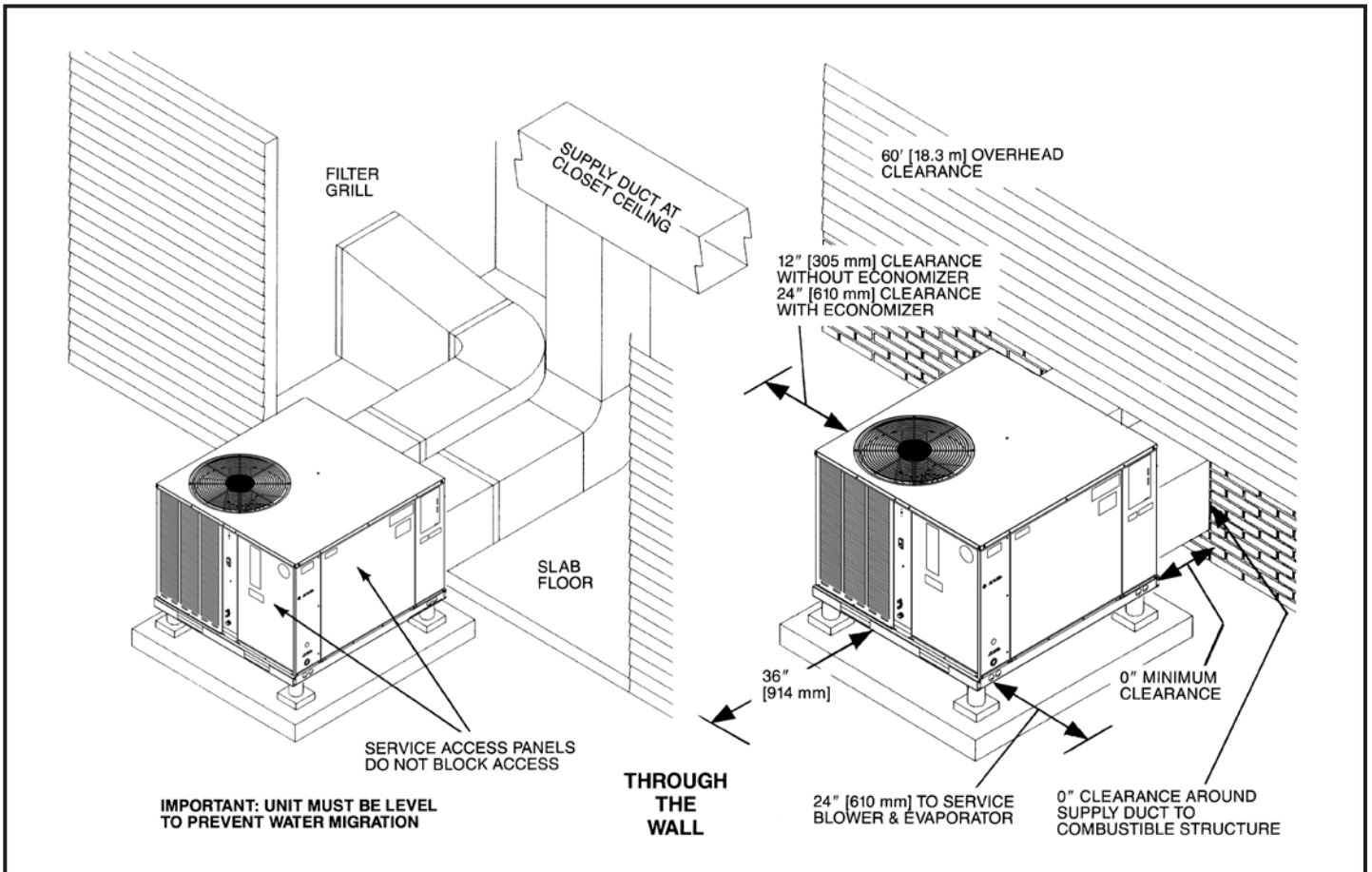

Illustration  
ST-A1334-02

[ ] Designates Metric Conversions



[ ] Designates Metric Conversions

## ACCESSORY EQUIPMENT

Accessory Description	Model Application	Accessory Model No.
Roofcurb	RHPA	RXSG-AAA08 (8" [203 mm] Height)
		RXSG-AAA14 (14" [356 mm] Height)
	RHPX	RXSG-AXA14 (14" [356 mm] Height)
		RXSG-AXA24 (24" [610 mm] Height)
Curb Adapter ("A" footprint to "X" footprint)	RHPX	RXRX-DXCAE
Supply & Return Diffusers	RHPA/X	RXRN-BD15
Economizers (Convertible)	RHPA	AXRD-01RACAM3
	RHPX	RXRE-11RXCAM3
Dual Enthalpy Kit	RHPA	RXAX-A04
	RHPX	RXRX-BV03
Fresh Air Damper	RHPA	AXRF-FAA1 (Fixed-35%)
		AXRF-FAB1 (Motorized-35%)
	RHPX	RXRF-FAA2 (Fixed-35%)
		RXRF-FAB2 (Motorized-35%)
Rectangular to Round Transition (Downflow)	RHPA/X	RXMC-CA02 (16" [406 mm] Ducts)
		RXMC-CA03 (18" [457 mm] Ducts)
Filter Kit	RHPA	RXRY-B01
	RHPX	RXRY-B02
Low Ambient Control	RHPA/X	RXPZ-G01
Duct Adapter Sideflow Square to Round Transition	RHPA/X	AXMC-BA01
Lift Kit	RHPA/X	RXML-A01
Split Door Design Kit	RHPX	RXRX-SDX01
Phase Monitor Kit	3ph-RHPA/X	RXRX-PM3A02

[ ] Designates Metric Conversions

## COMMON SUPPLY/RETURN CONCENTRIC AIR DIFFUSER

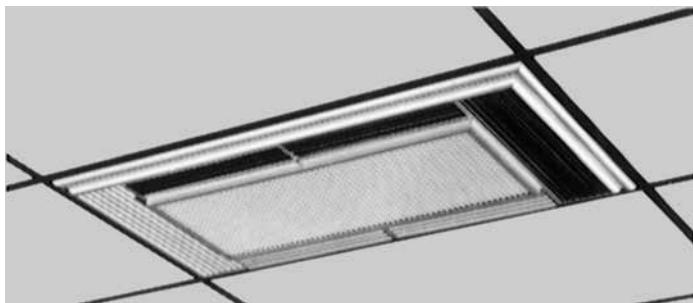

## SUPPLY/RETURN DIFFUSER

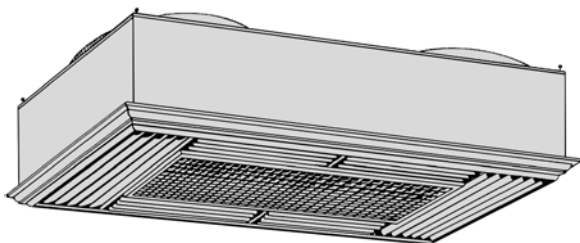

Designed to convert a side by side or an over and under arrangement into a concentric distribution of air. The diffuser is flush mounted, completely insulated, assembled, and internally baffled to provide four way supply air distribution with a center return. To make the assembly complete and ready to fit into a 2' [0.61 m] x 4' [1.22 m] suspended ceiling grid, the diffuser includes adjustable supply louvers, hanging rings, anti-sweat gasket, and round flanges for use with flexible ducts.

Model No. RXRN-	Diameter Inches [mm]	Shipping Wt. Lbs. [kg]	Dimension A Inches [mm]
BD15	16 [406]	90 [40.82]	20 <sup>1</sup> / <sub>2</sub> [521]

[ ] Designates Metric Conversions

DIFFUSER INSTALLS FLUSH WITH CEILING

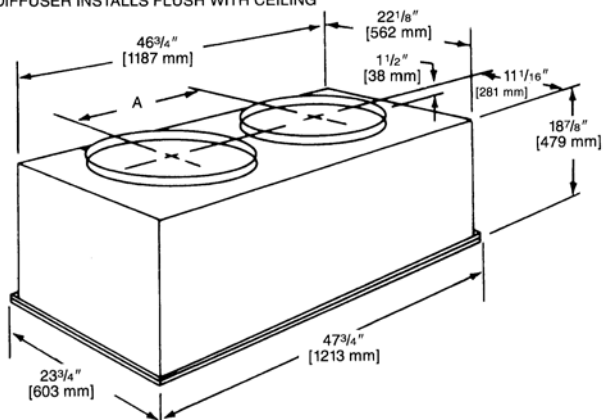

**NOTE:** The location of the combination supply and return diffuser should not exceed 10 feet [3.05 m] above the floor level for units @ 1000 CFM [472 L/s] or less and 12 [3.66 m] to 14 feet [4.27 m] above the floor level for units with CFM greater than 1000 [472 L/s]. If the diffuser is installed with a greater distance than recommended above, the supply air may become stratified above the required comfort area causing uncomfortable conditions.

## AIRFLOW/PRESSURE DROP INFORMATION (INCHES W.C. [kPa])

Accessory	Approximate CFM [L/s]-Supply Air			
	1300 [614]	1575 [743]	1800 [850]	2200 [1038]
Plenum & Supply/Return Duct	.07 [.017]	.10 [.024]	.12 [.030]	.17 [.042]
Diffuser	.09 [.022]	.13 [.032]	.16 [.040]	.24 [.060]
Economizer	.06 [.015]	.09 [.022]	.11 [.027]	.17 [.042]

## SUPPLY AIR/PERFORMANCE

Diffuser Airflow CFM [L/s]	Range of Throw Ft. [m]
800 [378]-1200 [566]	14 [4.27]-16 [4.88]
1600 [755]-2000 [944]	18 [5.49]-28 [8.53]





## FRESH AIR DAMPER

### For use on RHPAZR- Series

#### AXRF-FAA1 (Fixed - 0-35%)

The 0-35% manual outside Air Damper is designed to replace the unit return air duct cover. No drilling or damper assembly is required. The amount of outside air (0-35%) is controlled by simply adjusting the side damper.

#### AXRF-FAB1 (Motorized - 0-35%)

The 0-35% motorized outside Air Damper is designed to replace the unit return air duct cover. No drilling or damper assembly is required. The control motor opens the adjustable slide damper when the unit blower motor is energized.

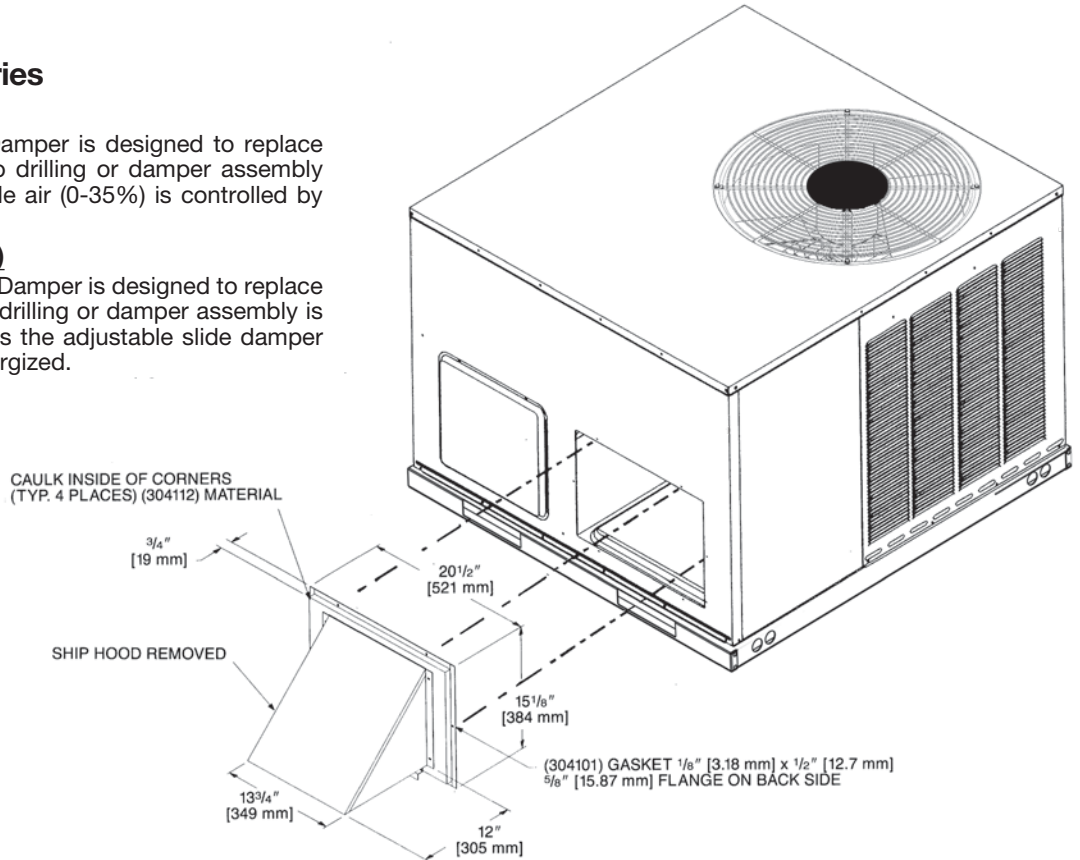

### For use on RHPXZR- Series

#### RXRF-FAA2 (Fixed - 0-35%)

The 0-35% manual outside Air Damper is designed to replace the unit return air duct cover. No drilling or damper assembly is required. The amount of outside air (0-35%) is controlled by simply adjusting the side damper.

#### RXRF-FAB2 (Motorized - 0-35%)

The 0-35% manual outside Air Damper is designed to replace the unit return air duct cover. No drilling or damper assembly is required. The amount of outside air (0-35%) is controlled by simply adjusting the side damper.

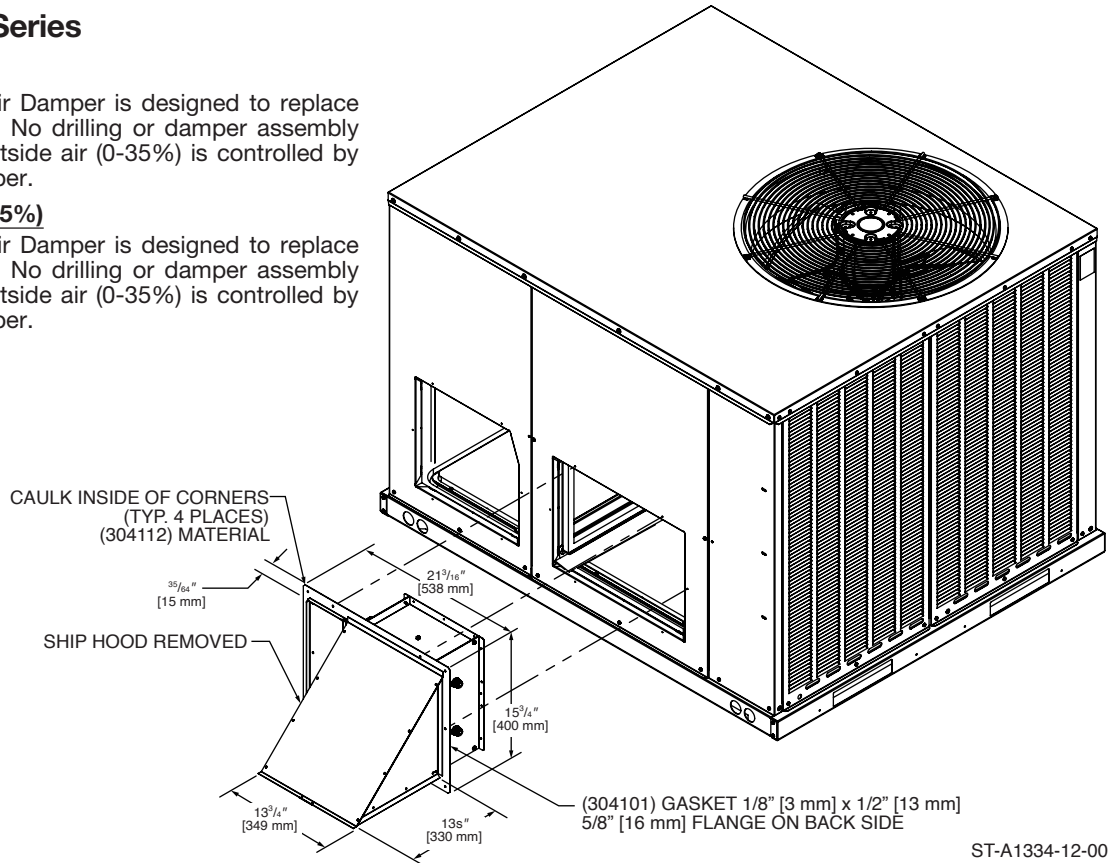

[ ] Designates Metric Conversions

ST-A1334-12-00

## ECONOMIZER

For use on RHPAZR- Series  
AXRD-01RACAM3 (Fully Modulating)  
Horizontally and Vertically Applicable

- LCD Screen for Continuous diagnostic and system status
- Programmable set points for accurate positioning
- Simplified wiring and color coded terminals
- Onboard fault detection and diagnostics (FDD)
- Operational Checkout to verify installation
- Enthalpy sensors and actuator that communicate through a Sylk Bus Network with the Jade Controller reducing wiring errors while providing more information
- CO<sub>2</sub> sensor input for DCV (Demand Control Ventilation) applications
- RXRX-AV04 Dual Enthalpy kit available for field installation
- AMCA licensed class 1A low leak Dampers

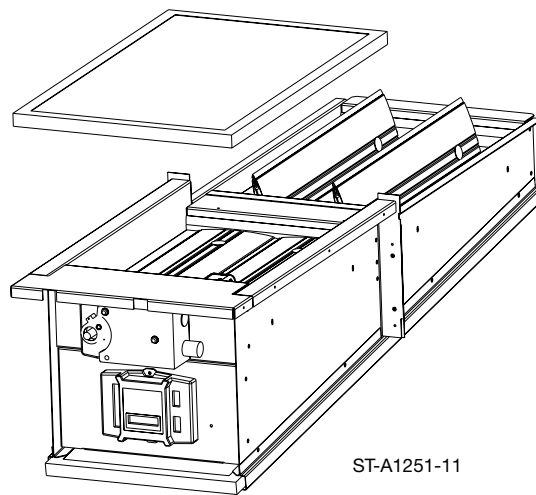
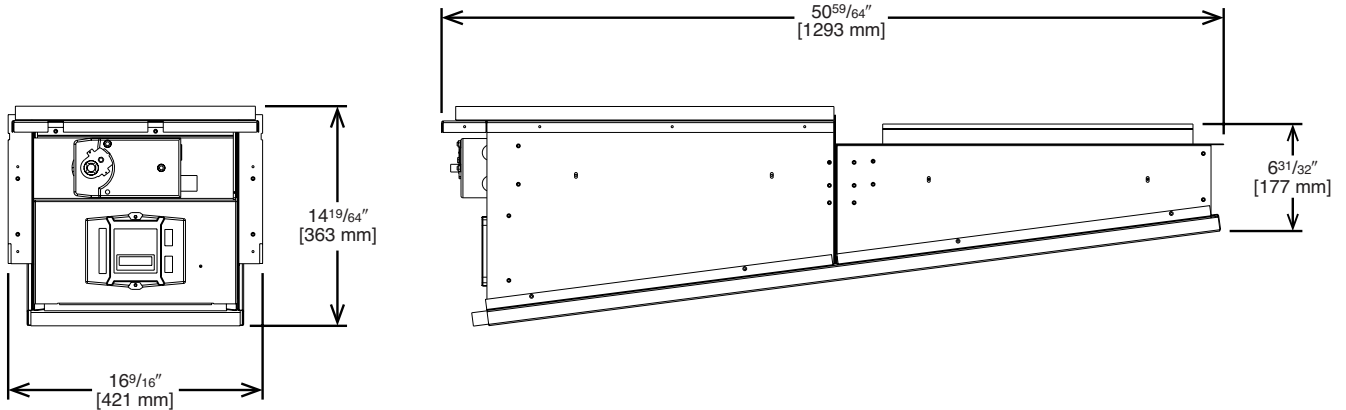
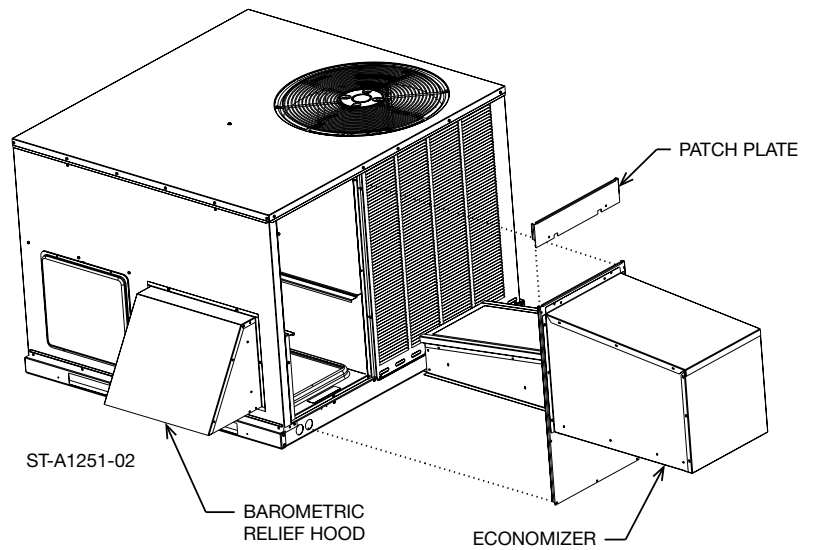

[ ] Designates Metric Conversions

## ECONOMIZER

### For use on RHPXZR- Series RXRE-11RXCAM3

- LCD Screen for Continuous diagnostic and system status
- Programmable set points for accurate positioning
- Simplified wiring and color coded terminals
- Onboard fault detection and diagnostics (FDD)
- Operational Checkout to verify installation
- Enthalpy sensors and actuator that communicate with Siemens controller reducing wiring errors while providing more information
- Setup and configure the economizer controller before putting it into usage by using the Climatix Mobile app or the inbuilt display
- CO2 sensor input for demand control ventilation (DCV) applications
- RXRX-BV03 dual enthalpy kit available for field installation
- AMCA licensed class 1A low leak dampers

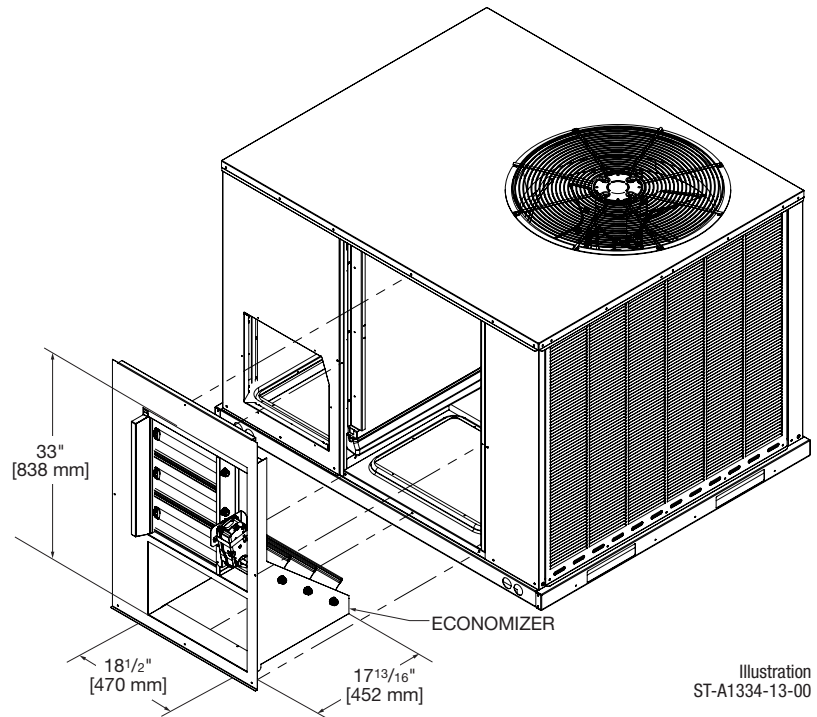

Illustration  
ST-A1334-13-00

#### VERTICAL APPLICATION

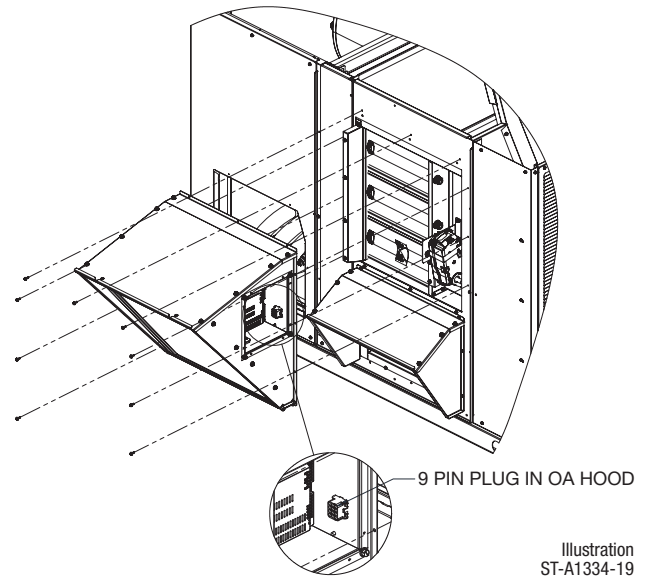
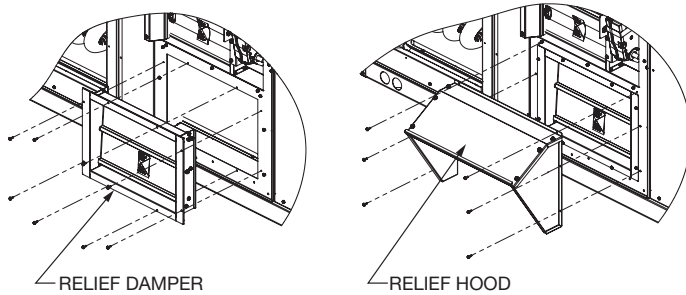

Illustration  
ST-A1334-19

#### HORIZONTAL APPLICATION

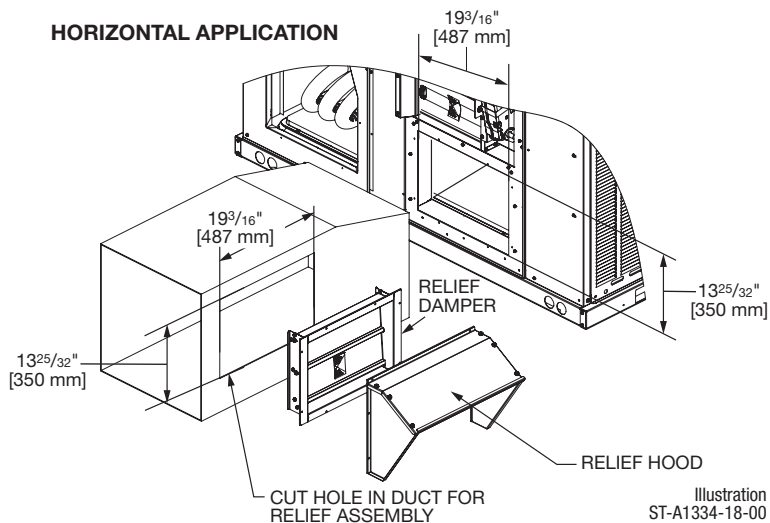

Illustration  
ST-A1334-18-00

[ ] Designates Metric Conversions



# FILTER KIT INSTALLATION RXRY-B01

For use in either vertical or horizontal discharge with the "A" cabinet.

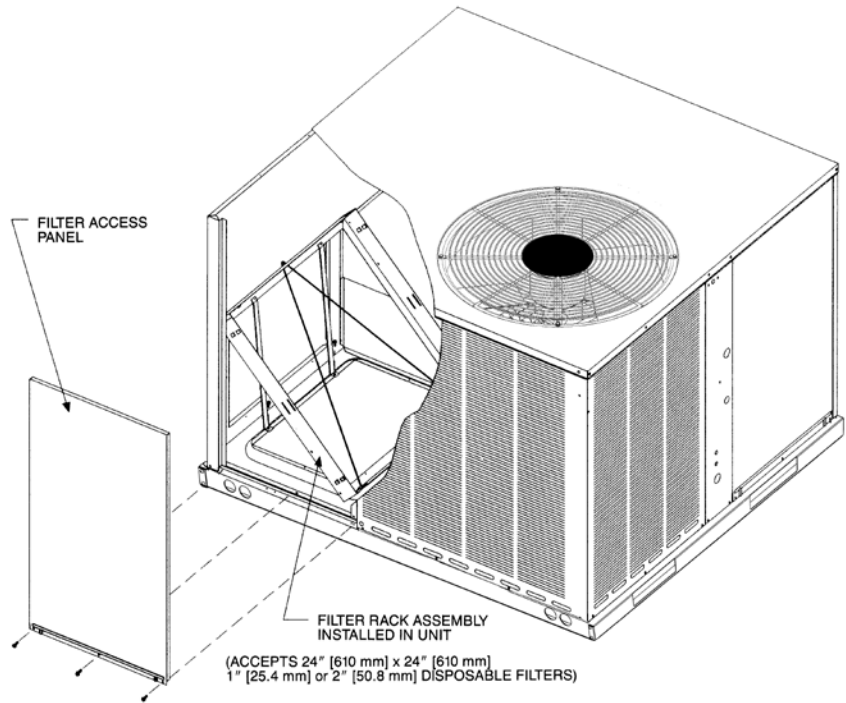

Airflow Pressure Drop, Inches W.C. [kPa]		
CFM [L/s]	1" Filter	2" Filter
500 [236]	.02 [.0050]	.03 [.0075]
600 [283]	.02 [.0050]	.03 [.0075]
700 [330]	.03 [.0075]	.04 [.0010]
800 [378]	.04 [.0010]	.05 [.0124]
900 [425]	.05 [.0124]	.06 [.0149]
1000 [472]	.07 [.0174]	.08 [.0199]
1100 [519]	.08 [.0199]	.09 [.0224]
1200 [566]	.10 [.0249]	.12 [.0299]
1300 [614]	.13 [.0324]	.15 [.0373]
1400 [661]	.16 [.0398]	.19 [.0473]
1500 [708]	.19 [.0473]	.21 [.0523]
1600 [755]	.20 [.0498]	.23 [.0572]
1700 [802]	.21 [.0523]	.24 [.0598]
1800 [850]	.22 [.0548]	.25 [.0623]
1900 [897]	.24 [.0598]	.27 [.0672]
2000 [944]	.26 [.0647]	.29 [.0722]

[ ] Designates Metric Conversions

## FILTER KIT INSTALLATION RXRY-B02

For use in either vertical or horizontal discharge with the "X" cabinet.

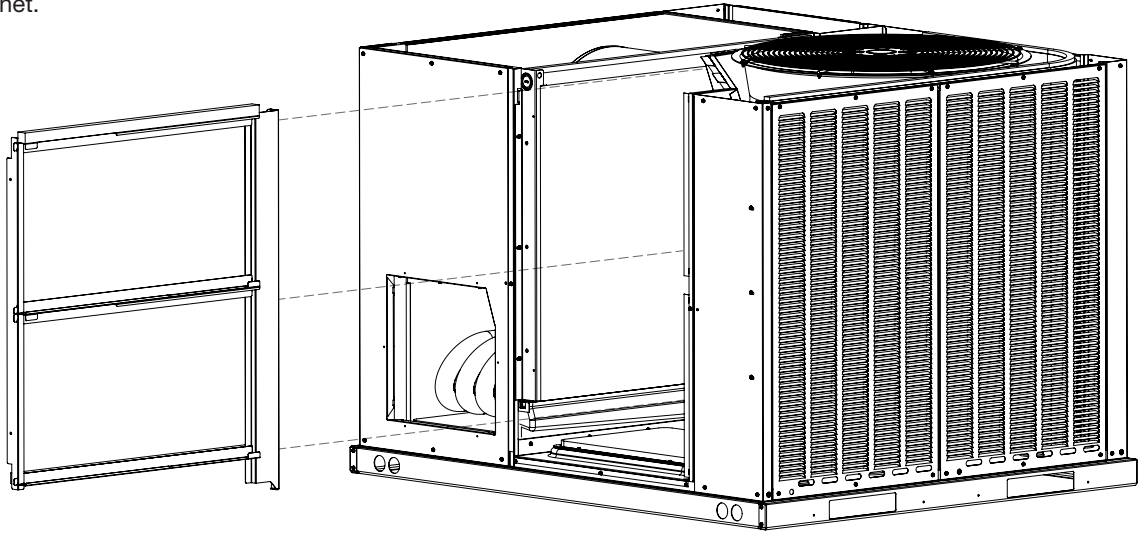

Illustration  
ST-A1352-01-00

Airflow Pressure Drop (1" filter)	
CFM [L/s]	Inches W.C. [kPa]
600 [283]	0.01 [0.002]
800 [378]	0.01 [0.002]
1000 [472]	0.02 [0.005]
1200 [566]	0.03 [0.008]
1400 [661]	0.05 [0.012]
1600 [755]	0.07 [0.017]
1800 [850]	0.08 [0.021]
2000 [944]	0.10 [0.026]

[ ] Designates Metric Conversions

## DUCT ADAPTER SIDEFLOW SQUARE TO ROUND TRANSITION AXMC-BA01

Adapts the side rectangular supply and return openings to 14" [356 mm] diameter round openings. Adapters provided with same finish as unit and also provided with thermal insulation.

[ ] Designates Metric Conversions

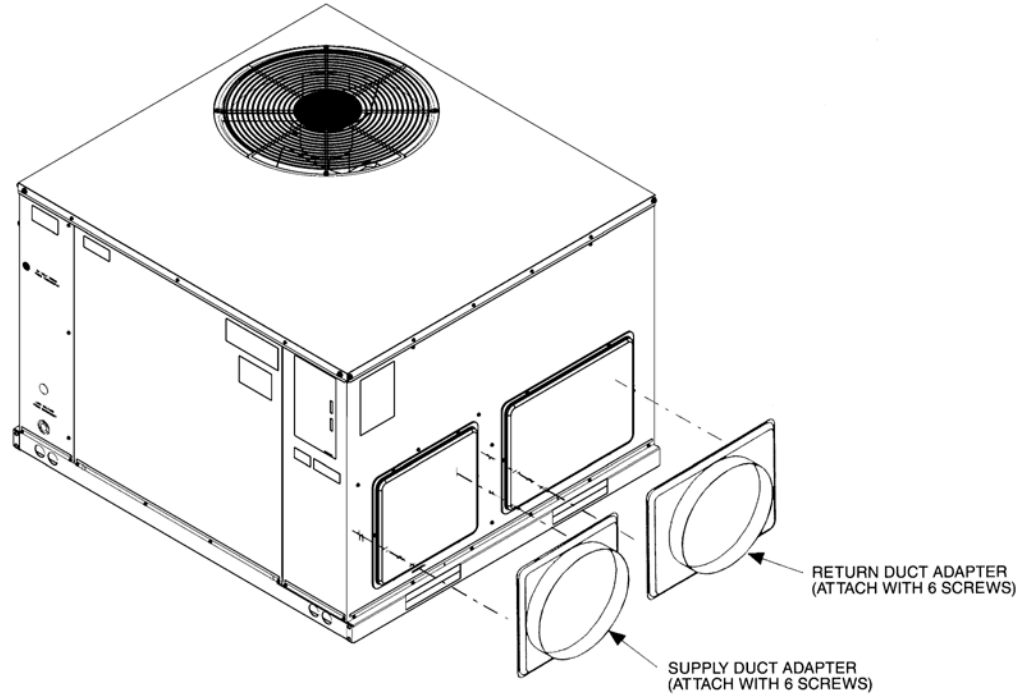



## ROOFCURB (Full Perimeter) RXSG-AXA14 & RXSG-AXA24 for RHPXZR - Series

Note: Hinged corners make  
for fast, easy set-up.

### RXSG-AXA14 (14" [356 mm] Height)

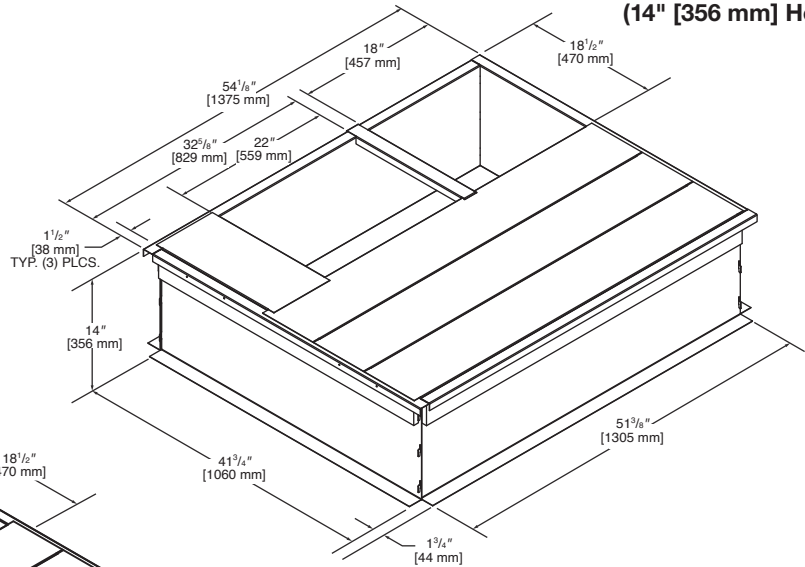

### RXSG-AXA24 (24" [610 mm] Height)

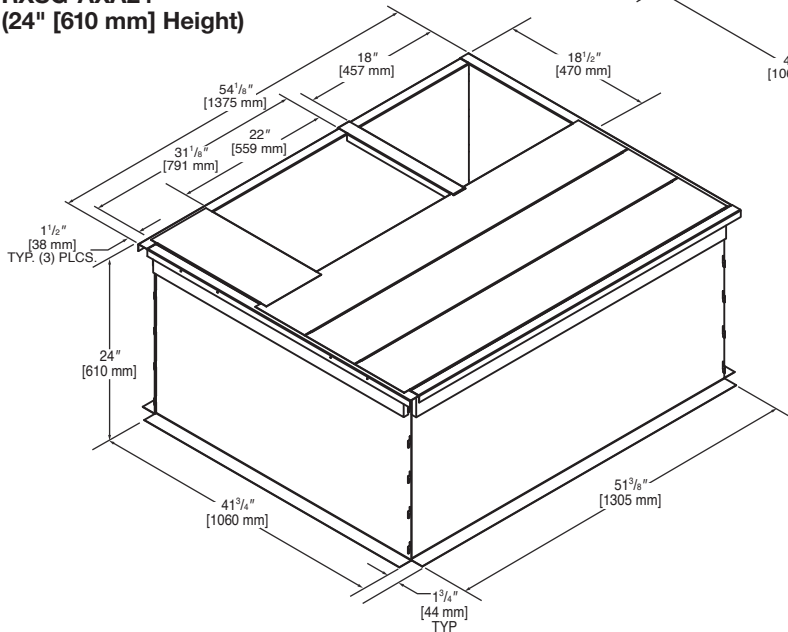

## PACKAGED HEAT PUMP ROOFCURB INSTALLATION (Full Perimeter)

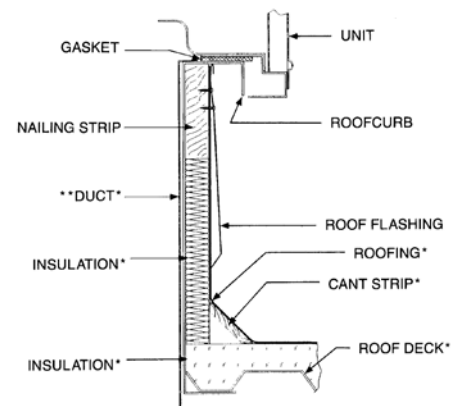
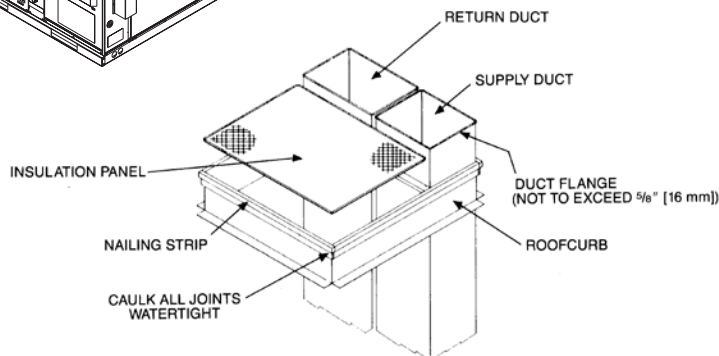
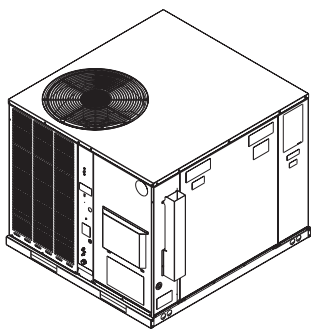

\*BY CONTRACTOR  
\*\*FOR INSTALLATION OF DUCT AS SHOWN, USE RECOMMENDED DUCT SIZES FROM  
ROOFCURB INSTALLATION INSTRUCTIONS. FOR DUCT FLANGE AT ATTACHMENT TO UNIT,  
SEE UNIT INSTALLATION INSTRUCTIONS FOR RECOMMENDED DUCT SIZES.

[ ] Designates Metric Conversions

## ROOFCURB ADAPTERS

Fabricated from galvanized steel to adapt the New cabinet to the old style curb. All are furnished with a New gasket.

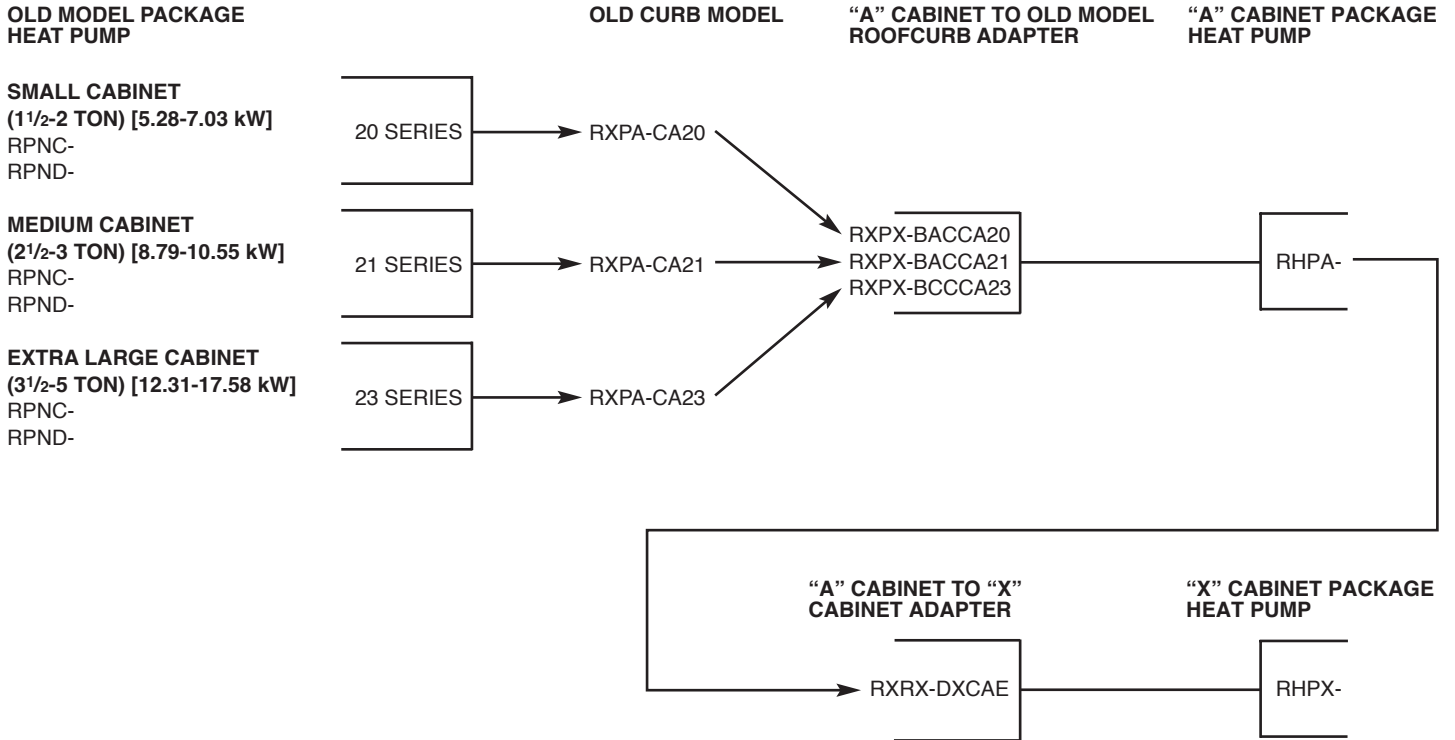

[ ] Designates Metric Conversions





**BEFORE PURCHASING THIS APPLIANCE, READ IMPORTANT ENERGY COST AND EFFICIENCY INFORMATION AVAILABLE FROM YOUR RETAILER.**

**GENERAL TERMS OF LIMITED WARRANTY\***

Ruud will furnish a replacement for any part of this product which fails in normal use and service within the applicable periods stated, in accordance with the terms of the limited warranty.

**\*For complete details of the Limited and Conditional Warranties, including applicable terms and conditions, contact your local contractor or the Manufacturer for a copy of the product warranty certificate.**

**Conditional Parts (Registration Required)**

1 Phase, Residential Applications ..... Ten (10) Years

**Compressor**

1 Phase, Residential Applications ..... Ten (10) Years

1 & 3 Phase, Commercial Applications ..... Five (5) Years

**Parts**

1 & 3 Phase, Commercial Applications ..... One (1) Year

**Before proceeding with installation, refer to installation instructions packaged with each model, as well as complying with all Federal, State, Provincial, and Local codes, regulations, and practices.**

© 2023 Rheem Manufacturing Company. Ruud trademarks owned by Rheem Manufacturing Company.

*In keeping with its policy of continuous progress and product improvement, Ruud reserves the right to make changes without notice.*

Ruud Heating, Cooling & Water Heating • 5600 Old Greenwood Road  
Fort Smith, Arkansas 72908 • [www.ruud.com](http://www.ruud.com)

Ruud Canada Ltd./Ltée • 125 Edgeware Road, Unit 1  
Brampton, Ontario • L6Y 0P5 • [ruud-canada.ca](http://ruud-canada.ca)