



# SERVICE PARTS LIST

**BULLETIN NO.**  
**54-26-2890**

SPECIFY CATALOG NO. AND SERIAL NO. WHEN ORDERING PARTS		REVISED BULLETIN	DATE
<b>M18™ FUEL™ 1/4" Hex Impact Driver</b>			Mar. 2018
CATALOG NO.	<b>2853-20</b>	STARTING SERIAL NO.	<b>J57A</b>
		WIRING INSTRUCTION <b>See Pages 2</b>	

**EXAMPLE:**  
Component Parts (Small #)  
Are Included When Ordering  
The Assembly (Large #).

00 0

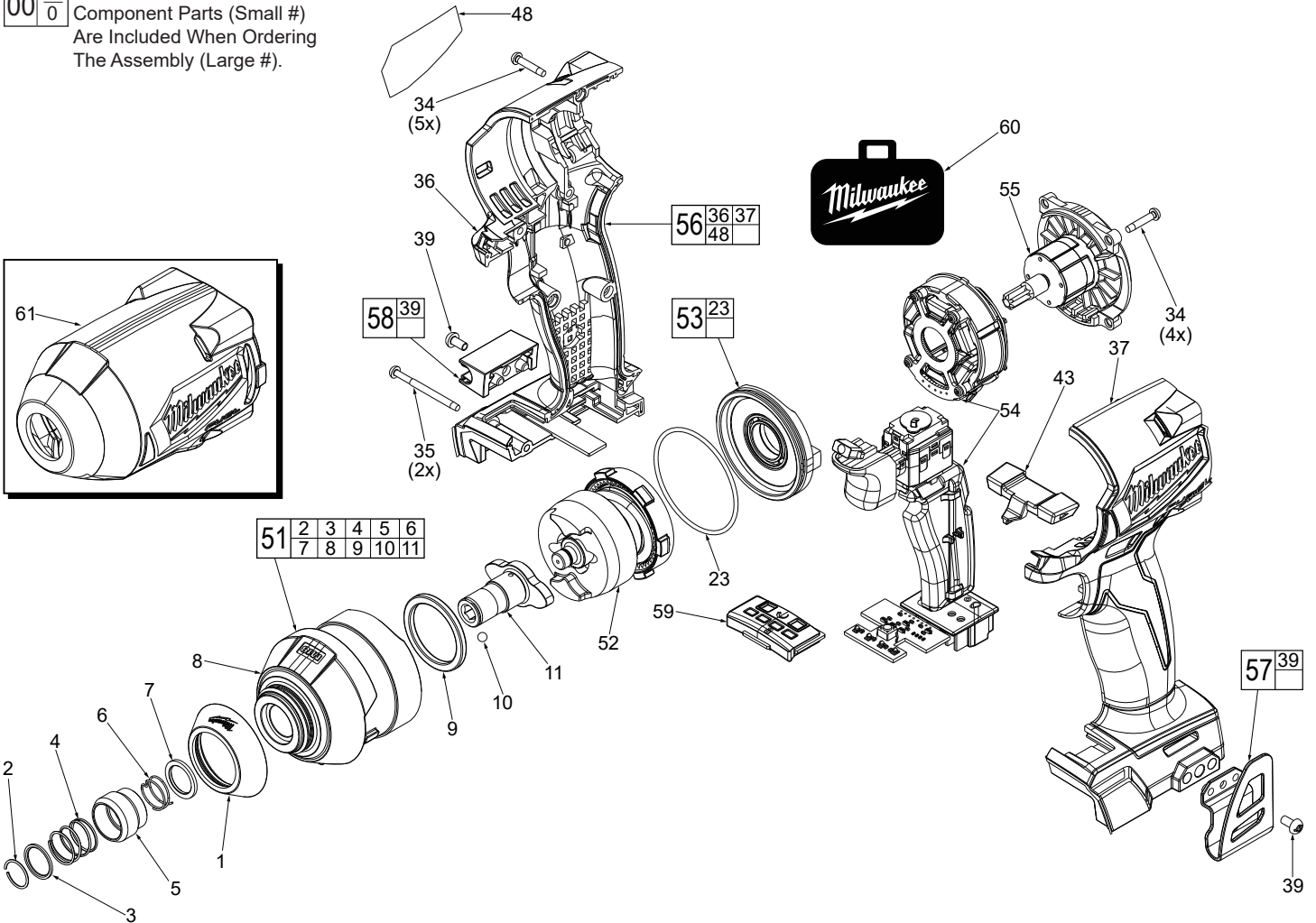
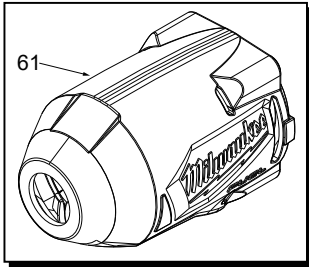
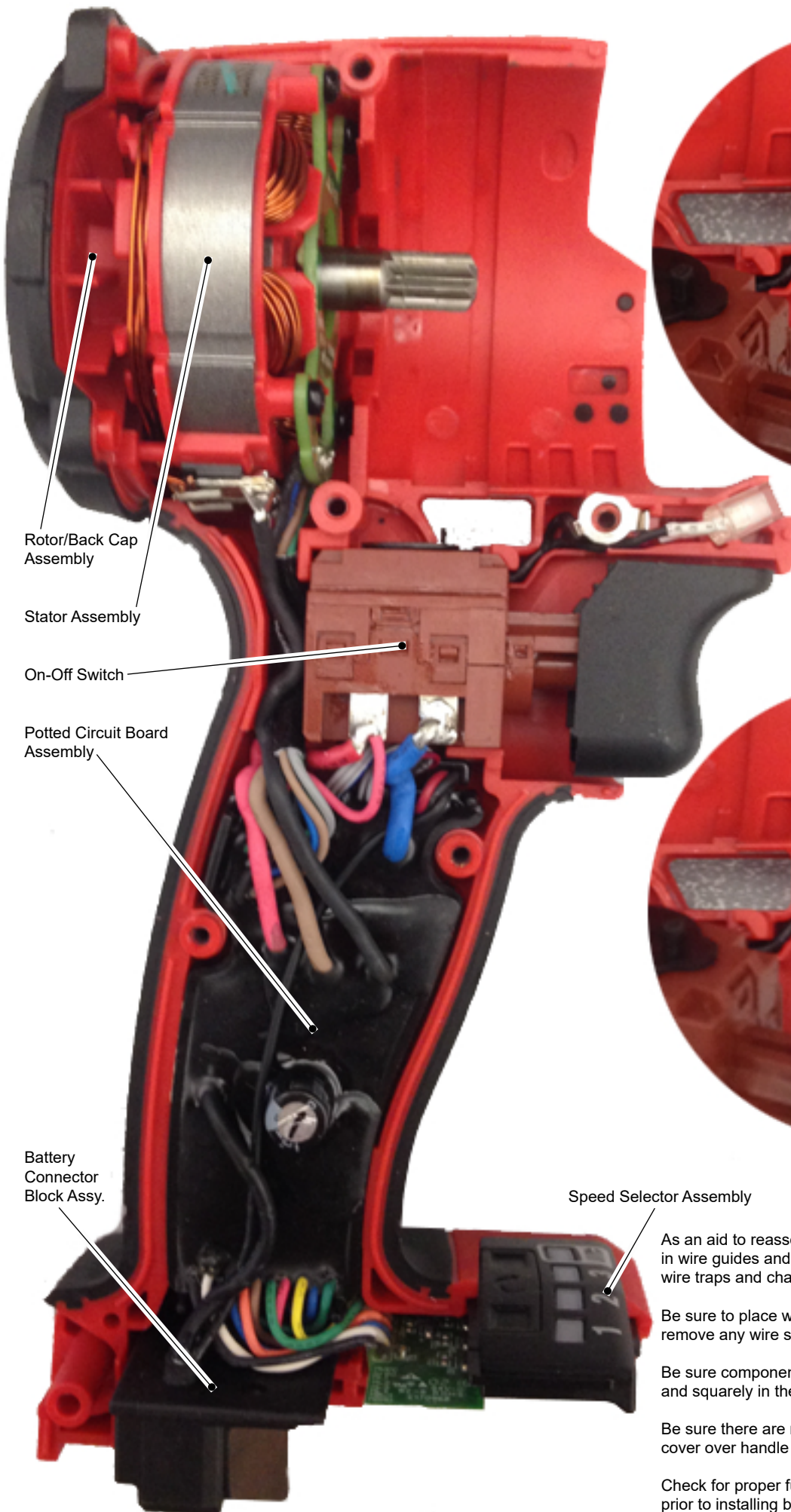

FIG.	PART NO.	DESCRIPTION OF PART	NO. REQ.
1	31-12-0203	Rubber Nose Cap	(1)
2	34-60-0005	Retaining Ring	(1)
3	45-88-2025	Washer	(1)
4	40-50-0056	Spring	(1)
5	42-76-0019	Sleeve	(1)
6	40-50-0057	Spring	(1)
7	45-88-1547	Washer	(1)
8	-----	Front Gear Case	(1)
9	45-88-2653	Front Gear Case Washer	(1)
10	02-02-1100	Steel Ball	(1)
11	42-06-2801	1/4" Hex Anvil	(1)
23	34-40-0596	O-Ring	(1)
34	06-82-6351	M3 x 16mm Pan Hd. ST T-10 Screw	(9)
35	06-82-2367	M3 x 38mm Pan Hd. ST T-10 Screw	(2)
36	-----	Right Housing Halve - Cover	(1)
37	-----	Left Housing Halve - Support	(1)
39	06-82-2500	6-32 Pan Hd. Slotted T-15 Mach. Scr.	(2)
43	45-24-0261	Forward/Reverse Shuttle	(1)
48	12-20-1217	Service Nameplate	(1)
51	14-30-2801	Gear Case Assembly	(1)
52	14-30-2806	Impacting Assembly	(1)
53	44-66-2681	End Cap Assembly	(1)
54	14-20-2821	Electronics Assembly	(1)
55	16-01-2831	Rotor/Back Cap Assembly	(1)
56	31-44-2866	Housing Assembly	(1)
57	42-70-0950	Belt Clip Kit	(1)
58	43-72-0950	Bit Holder Kit	(1)

FIG.	PART NO.	DESCRIPTION OF PART	NO. REQ.
59	45-24-1301	Speed Selector Assembly	(1)
60	42-55-0036	Blow Molded Carrying Case	(1)
61	49-16-2853	Rubber Boot, Accessory	(1)



Rotor/Back Cap Assembly

Stator Assembly

On-Off Switch

Potted Circuit Board Assembly

Battery Connector Block Assy.

Speed Selector Assembly

Ground Terminal

LED Assembly

Route the LED wires and ground wire from PCBA behind switch and through wire channels/traps as shown. Seat LED module squarely in cavity of left housing half. With LED in place, install ground terminal over screw boss. Place switch firmly and squarely into corresponding cavity of left housing half.

As an aid to reassembly, take note of wire routings and position in wire guides and traps while dismantling tool. Route wires into wire traps and channels as shown.

Be sure to place wires down into wire traps, being sure to remove any wire slack while routing.

Be sure components of electronics assembly are seated firmly and squarely in the corresponding cavity of handle support.

Be sure there are no interferences when installing handle cover over handle support. Watch for pinched wires.

Check for proper functionality of slide buttons and speed dial prior to installing battery.