

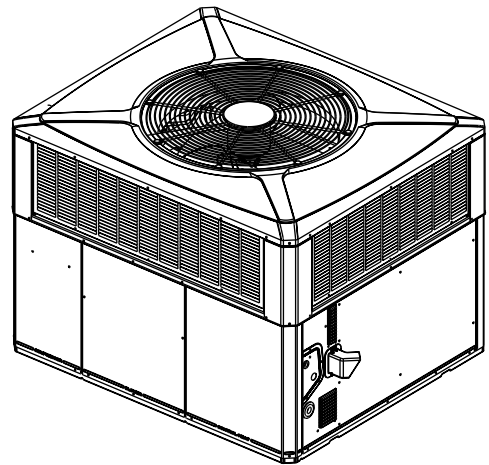

Product Data

Single Packaged Gas/Electric 13.4 SEER2 Convertible, 2 – 5 Ton

4YCC4024E1060A
4YCC4030E1070A
4YCC4036E1070A
4YCC4036E1090A
4YCC4042E1060A
4YCC4042E1090A
4YCC4048E1070A
4YCC4048E1090A
4YCC4060E1090A
4YCC4060E1115A



Note: "Graphics in this document are for representation only. Actual model may differ in appearance."



SAFETY SECTION

Important — This document contains a wiring diagram, a parts list, and service information. This is customer property and is to remain with this unit. Please return to service information pack upon completion of work.

⚠ WARNING

HAZARDOUS GASES!

Exposure to fuel substances or by-products of incomplete fuel combustion is believed by the state of California to cause cancer, birth defects, or other reproductive harm. This warning complies with state of California law, Proposition 65.

⚠ WARNING

HAZARDOUS VOLTAGE!

Failure to follow this Warning could result in property damage, severe personal injury, or death. Disconnect all electric power, including remote disconnects before servicing. Follow proper lockout/tagout procedures to ensure the power cannot be inadvertently energized.

⚠ WARNING

SAFETY AND ELECTRICAL HAZARD!

Failure to follow this Warning could result in property damage, severe personal injury, or death. These servicing instructions are for use by qualified personnel only. To reduce the risk of electrical shock, do not perform any servicing other than that contained in these operating instructions unless you are qualified to do so.

⚠ CAUTION

GROUNDING REQUIRED!

Failure to inspect or use proper service tools may result in equipment damage or personal injury. Reconnect all grounding devices. All parts of this product that are capable of conducting electrical current are grounded. If grounding wires, screws, straps, clips, nuts, or washers used to complete a path to ground are removed for service, they must be returned to their original position and properly fastened.

⚠ WARNING

UNIT CONTAINS R-410A REFRIGERANT!

Failure to use proper service tools may result in equipment damage or personal injury. R-410A operating pressure exceeds the limit of R-22. Proper service equipment is required. Service using only R-410A Refrigerant and approved POE compressor oil.

⚠ WARNING

SAFETY HAZARD!

Operating the unit without the access panels properly installed may result in severe personal injury or death. Do not operate the unit without the evaporator fan access panel or evaporator coil access panel in place.

⚠ WARNING**WARNING!**

This product can expose you to chemicals including lead, which are known to the State of California to cause cancer and birth defects or other reproductive harm. For more information go to www.P65Warnings.ca.gov.

***Important:** Wear appropriate gloves, arm sleeve protectors and eye protection when servicing or maintaining this equipment.*

***Important:** Air filters and media wheels or plates shall meet the test requirements in UL 900.*



Table of Contents

Single Packaged Convertible Gas/Electric Systems	5
Optional Equipment Listing	6
Product Specifications	8
Indoor Fan Performance	12
Wiring Diagrams	18
Full Perimeter Roof Mounting Curb	24
Optional Equipment — Economizer	26
Optional Equipment — Outside Air Damper	27
Optional Equipment — Filter Rack	28
Outline Drawings	29



Single Packaged Convertible Gas/Electric Systems

Trane offers a complete family of packaged gas/electric heating and cooling systems, designed to provide the unbeatable combination of energy efficiency and lower operating costs. In warm weather, the package gas/electric system functions as an all-electric, high efficiency air conditioner. In cold weather, it operates as a natural gas or propane gas furnace, offering the best of both energy worlds.

Because cooling and heating functions are all contained in a single cabinet, a single packaged convertible gas/electric system is easy to install and service.

It can be flush mounted beside your home at ground level or placed on the roof for horizontal or downflow installation. When connected to an optional American Standard thermostat control, and air distribution ducts, you have a highly efficient, total home comfort system.

Single Packaged Convertible Gas/Electric Systems are unmatched in quality and reliability.

All major components on these products, including the compressor, have been designed and manufactured for maximum service. Every compressor is designed and manufactured to exacting specifications. Each design is life tested in extreme environments to ensure reliable and long lasting operation in normal applications. Each compressor has internal motor protection for added reliability.

Single Packaged Convertible Gas/Electric Systems provide better performance.

Our single packaged cooling/heating units offer cooling/heating efficiencies that are unmatched in the industry and provide you with a product far superior in performance than the competition.



Optional Equipment Listing

* = T, W, or Y	
Hinged Filter Access Door (4*CC4024-036)	BAYCCDOR1A []
Hinged Filter Access Door (4*CC4042-060)	BAYCCDOR2A []
Roof Curb Full Perimeter (4*CC024-036)	BAYCURB050A []
Roof Curb Full Perimeter (4*CC042-060)	BAYCURB051A []
Roof Curb Utility Extension Kit (BAYCURB050A)	BAYUTIL101B []
Roof Curb Utility Extension Kit (BAYCURB051A)	BAYUTIL101B []
0-25% Manual Fresh Air Damper (4*CC4024-36) ^(a)	BAYOSAH001A []
0-25% Manual Fresh Air Damper (4*CC4042-60) ^(a)	BAYOSAH002A []
Motorized Fresh Air Damper (4*CC4024-036) ^(a)	BAYDMPR101A []
Motorized Fresh Air Damper (4*CC4042-060) ^(a)	BAYDMPR102A []
16" Round Duct Adapter (2 per box) (4*CC4024-036) ^(b)	BAYSQRD001A []
18" Round Duct Adapter (2 per box) (4*CC4024-060) ^(b)	BAYSQRD002A []
0-100% Mod Economizer w/Baro. Relief (4*CC4024-036) ^{(a)(c)(d)}	BAYECON101B []
0-100% Mod Economizer w/Baro. Relief (4*CC4042-060) ^{(a)(d)}	BAYECON102B []
0-100% Horizontal Economizer (4*CC4024-36) ^(a)	BAYECON200B []
0-100% Horizontal Economizer (4*CC4042-60) ^(a)	BAYECON201B []
Enthalpy Control for Economizer (ALL-BAYECON)	BAYEENTH001A []
Remote Potentiometer (ALL-BAYECON)	BAYSTAT023 []
1"-2" Filter Frame (4*CC4024-036) (18 x 25 filter not included)	BAYFLTR101C []
1"-2" Filter Frame (4*CC4042-060) (two 18 x 20 filters not included)	BAYFLTR201C []
Head Pressure Control (Low Ambient Cool) (208/240v) Kit	BAYLOAM105A []
Quick Start Kit (4WCC4, 4TCC4)	BAYQSTK300A []
Quick Start Kit (4YCC4)	BAYQSTK301A []
Crankcase Heater Scroll (4*CC4024-036) (230v)	BAYCCHT103A []
Crankcase Heater Scroll (4*CC4042-060) (230v)	BAYCCHT102A []
Crankcase Heater Scroll (4*CC4024-036) (230v)	BAYCCHT301A []
Crankcase Heater Scroll (4*CC4042-060) (230v)	BAYCCHT302A []
Adapter Curb (4*CC4024-36) to BAYCURB030, 38	BAYADAP050A []
Adapter Curb (4*CC4024-36) to BAYCURB033	BAYADAP051A []
Adapter Curb (4*CC4042-60) to BAYCURB030, 38	BAYADAP052A []
Adapter Curb (4*CC4042-60) to BAYCURB033	BAYADAP053A []
Adapter Curb (4*CC4042-60) to BAYCURB034	BAYADAP054A []
12" Duct Shroud Covers Horizontal (4*CC4024-060)	BAYCOVR112A []
18" Duct Shroud Covers Horizontal (4*CC4024-060)	BAYCOVR118A []
Extreme Condition Mounting Kit — All BAYCURB & BAYADAP	BAYEXMK001A []
Extreme Condition Mounting Kit — All BAYUTIL	BAYEXMK002B []
Extreme Condition Mounting Kit — All Slab Mounts	BAYEXMK003B []
Lifting Lug Kit	BAYLIFT002B []
LP Conversion Kit (All 115K Models)	BAYLPKT100A []
LP Conversion Kit (All 60K and 90K Models)	BAYLPKT101A []
LP Conversion Kit (All 70K Models)	BAYLPKT102A []



Optional Equipment Listing

SUPPLEMENTARY HEATERS (1 PHASE) * = T or W Only (Does not apply to Gas/Electric dual fuel models)	
3.76/5.0 KW Heater (208/240V 1 PH) (4*CC4024-060)	BAYHTRV105G []
6.0/8.0 KW Heater (208/240V 1 PH) (4*CC4024-060)	BAYHTRV108G []
7.50/10.0 KW Heater (208/240V 1 PH) (4*CC4024-060)	BAYHTRV110G []
11.27/15.0 KW Heater (208/240V 1 PH) (4*CC4030-060)	BAYHTRV115G []
15.0/20.0 KW Heater (208/240V 1 PH) (4*CC4048-060)	BAYHTRV120G []
18.78/25.0 KW Heater (208/240V 1 PH) (4*CC40060)	BAYHTRV125G []
Single Power Entry Kit ^(e)	BAYSPEK060G []
Single Power Entry Kit ^(e)	BAYSPEK062G []
Single Power Entry Kit ^(e)	BAYSPEK063G []

- (a) Must use internal filter frame when economizer or fresh air kit is used.
- (b) It is the responsibility of the installing dealer to properly size the ductwork for each specific application.
- (c) Dry bulb control standard with economizer.
- (d) Downflow only.
- (e) Must be selected per unit and heater model.



Product Specifications

MODEL	4YCC4024E 1060A	4YCC4030E 1070A	4YCC4036E 1070A	4YCC4036E 1090A
RATED Volts/PH/Hz	208-230/1/60	208-230/1/60	208-230/1/60	
Performance Cooling BTUH (a)	23200	28000	36400	
Indoor Airflow (CFM)	785	880	1215	
Power Input (KW)	1.94	2.21	3.17	
EER2/SEER2 (BTU/Watt-Hr.)	11.00 / 13.40	11.00 / 13.40	11.00 / 13.40	
Sound Power Rating [dB(A)] (b)	66.6	70.0	69.3	
PERFORMANCE HEATING (c)				
Input BTUH-1st Stage (Natural Gas) (d)	60000	70000	70000	90000
AFUE	81	81	81	
Temp. Rise — Min/Max (°F)	30 / 60	30 / 60	30 / 60	35 / 65
Orifice Qty/Drill Sz. (Natural Gas)	2 / #37	2 / #33	2 / #33	3 / #37
POWER CONN. — V/Ph/Hz	208-230/1/60	208-230/1/60	208-230/1/60	
Min. Brch. Cir. Ampacity (e)	16.7	20.8	26.2	
Fuse Size — Max. (amps)	25	30	40	
Fuse Size — Recmd. (amps)	25	30	40	
COMPRESSOR	SCROLL	SCROLL	SCROLL	
VOLTS/PH/HZ	208-230/1/60	208-230/1/60	208-230/1/60	
R.L. Amps — L.R. Amps	10.9 / 62.9	12.8 / 67.8	15.4 / 83.9	
OUTDOOR COIL — TYPE	SPINE-FIN	SPINE-FIN	SPINE-FIN	
Rows/F.P.I	2 / 24	2 / 24	2 / 24	
Face Area (sq. ft.)	13.32	13.32	15.49	
Tube Size (in.)	3/8	3/8	3/8	
INDOOR COIL — TYPE	MCHE	MCHE	MCHE	
Rows/F.P.I	2 / 16	2 / 16	2 / 16	
Face Area (sq. ft.)	2.7	2.7	2.7	
Tube Size Width (in.)	0.81	0.81	1	
Refrigeration Control	EXPANSION VALVE	EXPANSION VALVE	EXPANSION VALVE	
Drain Conn. Size (in.)	3/4 FEMALE NPT	3/4 FEMALE NPT	3/4 FEMALE NPT	
OUTDOOR FAN — TYPE	SWEPT	SWEPT	SWEPT	
DIA. (IN.)	23.4	23.4	23.4	
DRIVE/NO. SPEEDS	DIRECT / 1	DIRECT / 1	DIRECT / 1	
CFM @ 0.0 in. w.g. (f)	2350	2800	3080	
Motor — HP/R.P.M	1/12 / 810	1/6 / 825	1 / 5 / 825	
Volts/Ph/Hz	208-230/1/60	208-230/1/60	208-230 / 1 / 60	

Product Specifications

MODEL	4YCC4024E 1060A	4YCC4030E 1070A	4YCC4036E 1070A	4YCC4036E 1090A
F.L. Amps/L.R Amps	0.54 / 0.82	0.85 / 1.65	1.1 / 2.0	
INDOOR FAN — TYPE	CONSTANT TORQUE ECM	CONSTANT TORQUE ECM	CONSTANT TORQUE ECM	
Dia. x Width (in.)	10.62 X 10.62	10.62 X 10.62	10.62 X 10.62	
Drive/No. Speeds	DIRECT / 4	DIRECT / 4	DIRECT-4	
CFM @ 0.0 in. w.g. ^(g)	SEE FAN PERF TABLE	SEE FAN PERF TABLE	SEE FAN PERF TABLE	
Motor — HP/R.P.M.	1/3 / 1050	1/2 / 1050	3/4 / 1050	
Volts/Ph/Hz	208-230/1/60	208-230/1/60	208-230/1/60	
F.L. Amps	2.6	4.1	5.8	
COMBUSTION FAN — TYPE	CENTRIFUGAL	CENTRIFUGAL	CENTRIFUGAL	
Drive/No. Speeds	DIRECT / 1	DIRECT / 1	DIRECT / 1	
Motor — HP/R.P.M.	1/34 / 3345	1/34 / 3290	1/34 / 3290	1/34 / 3075
Volts/Ph/Hz	230/1/60	230/1/60	230/1/60	
FLA	0.20	0.20	0.20	0.24
FILTER / FURNISHED	NO	NO	NO	
Type Recommended	THROWAWAY	THROWAWAY	THROWAWAY	
Recmd. Face Area (sq. ft) ^(h)	4.0	4.0	4.0	
REFRIGERANT	R-410A	R-410A	R-410A	
Charge (lbs.)	5.4	7.38	7.2	
CHARGING SPECIFICATIONS				
Subcooling	10°	8°	11°	
GAS PIPE SIZE (in.)	1/2	1/2	1/2	
DIMENSIONS	H X D X W	H X D X W	H X D X W	
Crated (in.)	46 X 45 X 52	48 X 45 X 52	48 X 45 X 52	
WEIGHT				
Shipping (lbs.) / Net (lbs.)	432 / 358	451 / 377	438 / 374	453 / 379

^(a) Rated in accordance with AHRI Standard 210/240. AHRI standard rating conditions are: 80 D.B./67 W.B. entering air to indoor coil. 95 D.B. entering air to outdoor coil.

^(b) Sound Power values are not adjusted for AHRI 270-95 tonal corrections.

^(c) Ratings shown are for elevations up to 2000 ft. For higher elevations reduce ratings at a rate of 4% per 1000 ft. elevation.

^(d) Convertible to LPG.

^(e) This value is approximate. For more precise value, see Unit Nameplate.

^(f) Standard Air — Dry Coil — Outdoor.

^(g) Based on U.S. Government Standard Tests.

^(h) Filters must be installed in return air stream. Square footages listed are based on 300 f.p.m. face velocity. If permanent filters are used size per manufacturer's recommendation with a clean resistance of 0.05" W.C.



Product Specifications

MODEL	4YCC4042E 1060A	4YCC4042E 1090A	4YCC4048E 1070A	4YCC4048E 1090A	4YCC4060E 1090A	4YCC4060E 1115A
RATED Volts/PH/Hz	208-230/1/60		208-230/1/60		208-230/1/60	
Performance Cooling BTUH ^(a)	39500		46000		57000	
Indoor Airflow (CFM)	1450		1625		1770	
Power Input (KW)	3.53		4.2		4.98	
EER2/SEER2 (BTU/ Watt-Hr.)	11.00 / 13.40		10.80 / 13.40		11.00 / 13.40	
Sound Power Rating [dB(A)] ^(b)	74.6		72.5		73.1	
PERFORMANCE HEATING^(c)						
Input BTUH-1st Stage (Natural Gas) ^(d)	60000	90000	70000	90000	90000	115000
AFUE	81		81		81	
Temp. Rise — Min/ Max (°F)	30 / 60	35 / 65	30 / 60	35 / 65	30 / 60	
Orifice Qty/Drill Sz. (Natural Gas)	2 / #37	3 / #37	2 / #33	3 / #37	3 / #37	3 / #33
POWER CONN. — V/Ph/Hz	208-230/1/60		208-230/1/60		208-230/1/60	
Min. Brch. Cir. Ampacity ^(e)	28.3		31.8		39.1	
Fuse Size — Max. (amps)	45		50		60	
Fuse Size — Recmd. (amps)	45		50		60	
COMPRESSOR	SCROLL		SCROLL		SCROLL	
VOLTS/PH/HZ	208-230/1/60		208-230/1/60		208-230/1/60	
R.L. Amps — L.R. Amps	16.7 / 109.0		19.6 / 130.0		24.4 / 144.2	
OUTDOOR COIL — TYPE	SPINE-FIN		SPINE-FIN		SPINE-FIN	
Rows/F.P.I	2 / 24		2 / 24		2 / 24	
Face Area (sq. ft.)	15.63		20.54		22.99	
Tube Size (in.)	3/8		3/8		3/8	
INDOOR COIL — TYPE	MCHE		MCHE		PLATE FIN	
Rows/F.P.I	2 / 16		2 / 16		4 / 15	
Face Area (sq. ft.)	3.9		3.9		5.0	
Tube Size Width (in.)	0.81		0.81		3/8	
Refrigeration Control	EXPANSION VALVE		EXPANSION VALVE		EXPANSION VALVE	
Drain Conn. Size (in.)	3/4 FEMALE NPT		3/4 FEMALE NPT		3/4 FEMALE NPT	
OUTDOOR FAN — TYPE	SWEPT		SWEPT		SWEPT	
DIA. (IN.)	28.25		28.25		28.25	

Product Specifications

MODEL	4YCC4042E 1060A	4YCC4042E 1090A	4YCC4048E 1070A	4YCC4048E 1090A	4YCC4060E 1090A	4YCC4060E 1115A
DRIVE/NO. SPEEDS	DIRECT / 1		DIRECT / 1		DIRECT / 1	
CFM @ 0.0 in. w.g. ^(f)	3400		4800		4800	
Motor — HP/R.P.M	1/4 / 825		1/4 / 825		1/3 / 825	
Volts/Ph/Hz	208–230/1/60		208–230 / 1 / 60		208–230/1/60	
F.L. Amps/L.R Amps	1.51 / 3.07		1.51 / 3.07		1.7 / 3.5	
INDOOR FAN — TYPE	CONSTANT TORQUE ECM		CONSTANT TORQUE ECM		CONSTANT TORQUE ECM	
Dia. x Width (in.)	10.62 X 10.62		10.62 X 10.62		11.87 X 10.68	
Drive/No. Speeds	DIRECT / 4		DIRECT / 5		DIRECT / 4	
CFM @ 0.0 in. w.g. ^(g)	SEE FAN PERF TABLE		SEE FAN PERF TABLE		SEE FAN PERF TABLE	
Motor — HP/R.P.M.	3/4 / 1050		3/4 / 1050		1 / 1050	
Volts/Ph/Hz	208–230/1/60		208–230/1/60		208–230/1/60	
F.L. Amps	6		6		6.9	
COMBUSTION FAN — TYPE	CENTRIFUGAL		CENTRIFUGAL		CENTRIFUGAL	
Drive/No. Speeds	DIRECT / 1		DIRECT / 1		DIRECT / 1	
Motor — HP/R.P.M.	1/34 / 3345	1/34 / 3075	1/34 / 3290	1/34 / 3075	1/34 / 3075	1/34 / 3055
Volts/Ph/Hz	230/1/60		230/1/60		230/1/60	
FLA	0.20	0.24	0.20	0.24	0.24	0.25
FILTER / FURNISHED	NO		NO		NO	
Type Recommended	THROWAWAY		THROWAWAY		THROWAWAY	
Recmd. Face Area (sq. ft) ^(h)	5.3		5.3		5.3	
REFRIGERANT	R-410A		R-410A		R-410A	
Charge (lbs.)	7.3		7.5	7.5	9.65	9.65
CHARGING SPECIFICATIONS						
Subcooling	10°		10°		11°	
GAS PIPE SIZE (in.)	1/2		1/2		1/2	
DIMENSIONS	H X D X W		H X D X W		H X D X W	
Crated (in.)	46 X 47 X 62		50 X 47 X 62		50 X 47 X 62	
WEIGHT						
Shipping (lbs.) / Net (lbs.)	555 / 452	561 / 457	552 / 448	557 / 453	580 / 476	586 / 482

^(a) Rated in accordance with AHRI Standard 210/240. AHRI standard rating conditions are: 80 D.B.67 W.B. entering air to indoor coil. 95 D.B. entering air to outdoor coil.

^(b) Sound Power values are not adjusted for AHRI 270–95 tonal corrections.

^(c) Ratings shown are for elevations up to 2000 ft. For higher elevations reduce ratings at a rate of 4% per 1000 ft. elevation.

^(d) Convertible to LPG.

^(e) This value is approximate. For more precise value, see Unit Nameplate.

^(f) Standard Air — Dry Coil — Outdoor.

^(g) Based on U.S. Government Standard Tests.

^(h) Filters must be installed in return air stream. Square footages listed are based on 300 f.p.m. face velocity. If permanent filters are used size per manufacturer's recommendation with a clean resistance of 0.05" W.C.



Indoor Fan Performance

Table 1. Airflow Tables

4YCC4024E1060		EXTERNAL STATIC PRESSURE (IN.WG) Horizontal Airflow [Down Airflow]										
Motor Speed		0.0	0.1	0.2	0.3	0.4	0.5	0.6	0.7	0.8	0.9	1
Constant Circulation	CFM	APPROXIMATELY 40-50% COOLING OR HEATING AIRFLOW										
	WATTS											
Cooling - Low	CFM	-	900 (891)	846 (838)	794 (786)	729 (722)	-	-	-	-	-	-
	WATTS	-	114 (115)	121 (122)	128 (129)	138 (138)	-	-	-	-	-	-
Cooling - Med	CFM	-	-	-	890 (881)	836 (828)	777 (769)	707 (700)	-	-	-	-
	WATTS	-	-	-	158 (159)	167 (176)	175 (176)	185 (186)	-	-	-	-
Cooling - High	CFM	-	-	-	-	908 (899)	863 (854)	818 (810)	773 (765)	731 (724)	-	-
	WATTS	-	-	-	-	248 (249)	256 (258)	264 (266)	274 (276)	282 (284)	-	-
Heating - Low	CFM	1123 (1123)	1059 (1059)	994 (994)	943 (943)	889 (889)	-	-	-	-	-	-
	WATTS	143 (143)	152 (152)	160 (160)	167 (167)	175 (175)	-	-	-	-	-	-
Heating - High	CFM	-	-	1122 (1122)	1069 (1069)	1022 (1022)	974 (974)	922 (922)	871 (871)	809 (809)	-	-
	WATTS	-	-	213 (213)	221 (221)	229 (229)	238 (238)	245 (245)	253 (253)	261 (261)	-	-

Note: Cooling airflow must not exceed 900 CFM due to condensate blowoff.

4YCC4030E1070		EXTERNAL STATIC PRESSURE (IN.WG) Horizontal Airflow [Down Airflow]										
Motor Speed		0.0	0.1	0.2	0.3	0.4	0.5	0.6	0.7	0.8	0.9	1
Constant Circulation	CFM	APPROXIMATELY 40-50% COOLING OR HEATING AIRFLOW										
	WATTS											
Cooling - Low	CFM	1051 (1041)	994 (984)	939 (930)	889 (880)	840 (831)	-	-	-	-	-	-
	WATTS	126 (126)	134 (135)	142 (143)	150 (150)	158 (158)	-	-	-	-	-	-
Cooling - Med	CFM	-	-	1108 (1097)	1070 (1059)	1027 (1017)	975 (965)	920 (911)	875 (866)	-	-	-
	WATTS	-	-	239 (240)	247 (248)	256 (258)	267 (269)	274 (276)	282 (284)	-	-	-
Cooling - High	CFM	-	-	-	-	1099 (1088)	1059 (1048)	1017 (1007)	968 (959)	-	-	-
	WATTS	-	-	-	-	259 (260)	268 (270)	278 (279)	289 (290)	-	-	-
Heating - Low	CFM	1148 (1136)	1103 (1091)	1061 (1050)	1022 (1012)	982 (972)	932 (922)	-	-	-	-	-
	WATTS	199 (197)	208 (205)	216 (214)	224 (222)	233 (230)	243 (241)	-	-	-	-	-
Heating - High	CFM	-	-	-	1158 (1147)	1122 (1111)	1084 (1073)	1039 (1028)	988 (978)	-	-	-
	WATTS	-	-	-	301 (298)	310 (307)	320 (317)	331 (328)	343 (339)	-	-	-

Note: Cooling airflow must not exceed 1125 CFM due to condensate blowoff.

Indoor Fan Performance

4YCC4036E1070		EXTERNAL STATIC PRESSURE (IN.WG) Horizontal Airflow [Down Airflow]										
Motor Speed		0.0	0.1	0.2	0.3	0.4	0.5	0.6	0.7	0.8	0.9	1
Constant Circulation	CFM	APPROXIMATELY 40-50% COOLING OR HEATING AIRFLOW										
	WATTS											
Cooling - Low	CFM	-	1272 (1259)	1243 (1231)	1214 (1202)	1186 (1174)	1154 (1142)	1116 (1105)	1072 (1061)	-	-	-
	WATTS	-	352 (354)	361 (363)	372 (374)	382 (384)	392 (394)	404 (406)	416 (418)	-	-	-
Cooling - Med	CFM	-	-	-	-	1349 (1336)	1319 (1306)	1277 (1264)	1242 (1230)	1199 (1187)	1160 (1148)	1124 (1113)
	WATTS	-	-	-	-	489 (492)	500 (503)	511 (514)	523 (526)	537 (540)	548 (551)	558 (561)
Cooling - High	CFM	-	-	-	-	-	1326 (1299)	1296 (1270)	1263 (1238)	1225 (1201)	1183 (1159)	1150 (1127)
	WATTS	-	-	-	-	-	516 (519)	527 (530)	539 (542)	552 (555)	566 (569)	575 (578)
Heating - Low	CFM	1185 (1173)	1141 (1130)	1099 (1088)	1055 (1044)	1009 (999)	968 (958)	920 (911)	854 (846)	808 (800)	731 (724)	624 (618)
	WATTS	241 (238)	251 (248)	260 (258)	270 (267)	279 (277)	289 (286)	299 (296)	311 (308)	320 (316)	306 (303)	284 (282)
Heating - High	CFM	1386 (1373)	1354 (1340)	1311 (1298)	1276 (1263)	1238 (1225)	1198 (1186)	1164 (1153)	1069 (1058)	805 (797)	689 (682)	596 (590)
	WATTS	386 (382)	399 (395)	409 (405)	419 (415)	430 (425)	441 (437)	452 (448)	432 (428)	320 (317)	303 (300)	298 (295)

Note: Cooling airflow must not exceed 1350 CFM due to condensate blowoff.

4YCC4036E1090		EXTERNAL STATIC PRESSURE (IN.WG) Horizontal Airflow [Down Airflow]										
Motor Speed		0.0	0.1	0.2	0.3	0.4	0.5	0.6	0.7	0.8	0.9	1
Constant Circulation	CFM	APPROXIMATELY 40-50% COOLING OR HEATING AIRFLOW										
	WATTS											
Cooling - Low	CFM	1288 (-)	1254 (1238)	1225 (1207)	1193 (1176)	1158 (1143)	1117 (1091)	1070 (-)	-	-	-	-
	WATTS	340 (-)	348 (348)	357 (357)	366 (366)	375 (375)	385 (385)	395 (-)	-	-	-	-
Cooling - Med	CFM	-	1326 (1320)	1300 (1294)	1271 (1263)	1241 (1234)	1201 (1196)	1107 (1102)	-	-	-	-
	WATTS	-	410 (410)	419 (419)	427 (427)	437 (437)	447 (447)	423 (423)	-	-	-	-
Cooling - High	CFM	-	-	-	-	1349 (1336)	1319 (1306)	1277 (1264)	1242 (1230)	1199 (1187)	1160 (1148)	1124 (1113)
	WATTS	-	-	-	-	489 (492)	500 (503)	511 (514)	523 (526)	537 (540)	548 (551)	558 (561)
Heating - Low	CFM	1292 (1285)	1259 (1252)	1230 (1222)	1199 (1186)	1163 (1148)	1124 (1111)	1071 (1060)	963 (954)	799 (781)	638 (-)	-
	WATTS	343 (343)	351 (351)	360 (360)	369 (369)	378 (378)	388 (388)	398 (398)	370 (370)	316 (316)	293 (-)	-
Heating - High	CFM	1367 (1355)	1341 (1326)	1310 (1295)	1282 (1267)	1250 (1235)	1212 (1183)	1075 (1056)	928 (913)	781 (-)	631 (-)	-
	WATTS	404 (404)	413 (413)	421 (421)	431 (431)	439 (439)	448 (448)	404 (404)	346 (346)	302 (-)	282 (-)	-

Note: Cooling airflow must not exceed 1350 CFM due to condensate blowoff.



Indoor Fan Performance

4YCC4042E1060		EXTERNAL STATIC PRESSURE (IN.WG) Horizontal Airflow [Down Airflow]										
Motor Speed		0.0	0.1	0.2	0.3	0.4	0.5	0.6	0.7	0.8	0.9	1
Constant Circulation	CFM	APPROXIMATELY 40-50% COOLING OR HEATING AIRFLOW										
	WATTS											
Cooling - Low	CFM	1358 (1345)	1393 (1379)	1348 (1334)	1296 (1283)	1253 (1241)	-	-	-	-	-	-
	WATTS	224 (228)	233 (238)	242 (247)	252 (257)	262 (267)	-	-	-	-	-	-
Cooling - Med	CFM	1521 (1506)	1490 (1475)	1448 (1433)	1391 (1377)	1362 (1348)	1338 (1325)	1315 (1302)	1307 (1293)	1254 (1241)	-	-
	WATTS	306 (312)	316 (322)	327 (333)	337 (344)	348 (354)	359 (366)	369 (377)	382 (389)	395 (403)	-	-
Cooling - High	CFM	-	-	-	-	1529 (1514)	1491 (1476)	1467 (1453)	1425 (1411)	1385 (1371)	1345 (1331)	-
	WATTS	-	-	-	-	455 (464)	467 (477)	477 (487)	490 (499)	503 (513)	513 (523)	-
Heating - Low	CFM	1104 (1109)	1042 (1047)	977 (982)	911 (916)	841 (845)	764 (767)	687 (690)	598 (601)	-	-	-
	WATTS	109 (109)	116 (117)	124 (125)	134 (134)	142 (143)	152 (153)	161 (162)	171 (172)	-	-	-
Heating - High	CFM	-	1171 (1177)	1112 (1117)	1050 (1055)	990 (995)	927 (931)	821 (856)	779 (783)	704 (707)	-	-
	WATTS	-	154 (155)	162 (163)	172 (173)	182 (182)	192 (193)	203 (204)	214 (215)	225 (226)	-	-

Note: Cooling airflow must not exceed 1575 CFM due to condensate blowoff.

4YCC4042E1090		EXTERNAL STATIC PRESSURE (IN.WG) Horizontal Airflow [Down Airflow]										
Motor Speed		0.0	0.1	0.2	0.3	0.4	0.5	0.6	0.7	0.8	0.9	1
Constant Circulation	CFM	APPROXIMATELY 40-50% COOLING OR HEATING AIRFLOW										
	WATTS											
Cooling - Low	CFM	1358 (1345)	1393 (1379)	1348 (1334)	1296 (1283)	1253 (1241)	-	-	-	-	-	-
	WATTS	224 (228)	233 (238)	242 (247)	252 (257)	262 (267)	-	-	-	-	-	-
Cooling - Med	CFM	1521 (1506)	1490 (1475)	1448 (1433)	1391 (1377)	1362 (1348)	1338 (1325)	1315 (1302)	1307 (1293)	1254 (1241)	-	-
	WATTS	306 (312)	316 (322)	327 (333)	337 (344)	348 (354)	359 (366)	369 (377)	382 (389)	395 (403)	-	-
Cooling - High	CFM	-	-	-	-	1529 (1514)	1491 (1476)	1467 (1453)	1425 (1411)	1385 (1371)	1345 (1331)	-
	WATTS	-	-	-	-	455 (464)	467 (477)	477 (487)	490 (499)	503 (513)	513 (523)	-
Heating - Low	CFM	1419 (1426)	1380 (1387)	1341 (1348)	1295 (1301)	1249 (1255)	1204 (1210)	1160 (1166)	1115 (1120)	1069 (1074)	1015 (1020)	961 (966)
	WATTS	240 (241)	250 (251)	259 (260)	269 (270)	279 (281)	291 (292)	302 (303)	312 (314)	323 (325)	333 (335)	348 (349)
Heating - High	CFM	1559 (1567)	1524 (1531)	1483 (1491)	1443 (1450)	1401 (1408)	1363 (1370)	1319 (1326)	1276 (1282)	1233 (1239)	1195 (1201)	1147 (1152)
	WATTS	313 (315)	324 (325)	335 (337)	346 (347)	356 (358)	367 (368)	379 (381)	392 (394)	403 (405)	415 (417)	428 (430)

Note: Cooling airflow must not exceed 1575 CFM due to condensate blowoff.

Indoor Fan Performance

4YCC4048E1070		EXTERNAL STATIC PRESSURE (IN.WG) Horizontal Airflow [Down Airflow]										
Motor Speed		0.0	0.1	0.2	0.3	0.4	0.5	0.6	0.7	0.8	0.9	1
Constant Circulation	CFM	APPROXIMATELY 40-50% COOLING OR HEATING AIRFLOW										
	WATTS											
Cooling - Low	CFM	1583 (1567)	1542 (1526)	1502 (1487)	1460 (1445)	1415 (1401)	-	-	-	-	-	-
	WATTS	302 (308)	313 (320)	324 (330)	332 (339)	346 (352)	-	-	-	-	-	-
Cooling - Med	CFM	1763 (1745)	1723 (1706)	1689 (1672)	1648 (1632)	1609 (1593)	1568 (1552)	1527 (1512)	1488 (1473)	1447 (1433)	-	-
	WATTS	414 (422)	426 (434)	436 (444)	448 (457)	459 (468)	471 (480)	483 (493)	495 (505)	510 (520)	-	-
Cooling - Med High	CFM	-	1786 (1768)	1757 (1739)	1729 (1712)	1700 (1683)	1675 (1658)	1648 (1632)	1624 (1608)	1504 (1489)	-	-
	WATTS	-	577 (589)	591 (603)	604 (616)	617 (629)	631 (644)	643 (656)	655 (668)	599 (611)	-	-
Cooling - High	CFM	-	-	-	-	-	1769 (1751)	1728 (1711)	1688 (1671)	1652 (1635)	1545 (1530)	-
	WATTS	-	-	-	-	-	613 (625)	631 (644)	643 (656)	647 (660)	611 (623)	-
Heating - Low	CFM	1120 (1126)	1047 (1052)	980 (985)	914 (918)	840 (845)	758 (762)	674 (677)	581 (584)	-	-	-
	WATTS	117 (117)	126 (127)	135 (136)	145 (146)	156 (156)	168 (168)	179 (180)	188 (189)	-	-	-
Heating - High	CFM	-	1204 (1210)	1149 (1154)	1095 (1100)	1043 (1048)	989 (994)	926 (930)	858 (862)	798 (802)	-	-
	WATTS	-	176 (177)	185 (186)	195 (196)	205 (206)	216 (217)	227 (228)	239 (240)	249 (250)	-	-

Note: Cooling airflow must not exceed 1800 CFM due to condensate blowoff.

4YCC4048E1090		EXTERNAL STATIC PRESSURE (IN.WG) Horizontal Airflow [Down Airflow]										
Motor Speed		0.0	0.1	0.2	0.3	0.4	0.5	0.6	0.7	0.8	0.9	1
Constant Circulation	CFM	APPROXIMATELY 40-50% COOLING OR HEATING AIRFLOW										
	WATTS											
Cooling - Low	CFM	1583 (1567)	1542 (1526)	1502 (1487)	1460 (1445)	1415 (1401)	-	-	-	-	-	-
	WATTS	302 (308)	313 (320)	324 (330)	332 (339)	346 (352)	-	-	-	-	-	-
Cooling - Med	CFM	1763 (1745)	1723 (1706)	1689 (1672)	1648 (1632)	1609 (1593)	1568 (1552)	1527 (1512)	1488 (1473)	1447 (1433)	-	-
	WATTS	414 (422)	426 (434)	436 (444)	448 (457)	459 (468)	471 (480)	483 (493)	495 (505)	510 (520)	-	-
Cooling - Med High	CFM	-	1786 (1768)	1757 (1739)	1729 (1712)	1700 (1683)	1675 (1658)	1648 (1632)	1624 (1608)	1504 (1489)	-	-
	WATTS	-	577 (589)	591 (603)	604 (616)	617 (629)	631 (644)	643 (656)	655 (668)	599 (611)	-	-
Cooling - High	CFM	-	-	-	-	-	1769 (1751)	1728 (1711)	1688 (1671)	1652 (1635)	1545 (1530)	-
	WATTS	-	-	-	-	-	613 (625)	631 (644)	643 (656)	647 (660)	611 (623)	-
Heating - Low	CFM	1419 (1426)	1380 (1387)	1341 (1348)	1295 (1301)	1249 (1255)	1204 (1210)	1160 (1166)	1115 (1120)	1069 (1074)	1015 (1020)	961 (966)
	WATTS	240 (241)	250 (251)	259 (260)	269 (270)	279 (281)	291 (292)	302 (303)	312 (314)	323 (325)	333 (335)	348 (349)
Heating - High	CFM	1559 (1567)	1524 (1531)	1483 (1491)	1443 (1450)	1401 (1408)	1363 (1370)	1319 (1326)	1276 (1282)	1233 (1239)	1195 (1201)	1147 (1152)
	WATTS	313 (315)	324 (325)	335 (337)	346 (347)	356 (358)	367 (368)	379 (381)	392 (394)	403 (405)	415 (417)	428 (430)

Note: Cooling airflow must not exceed 1800 CFM due to condensate blowoff.



Indoor Fan Performance

4YCC4060E1090		EXTERNAL STATIC PRESSURE (IN.WG) Horizontal Airflow [Down Airflow]										
Motor Speed		0.0	0.1	0.2	0.3	0.4	0.5	0.6	0.7	0.8	0.9	1
Constant Circulation	CFM	APPROXIMATELY 40-50% COOLING OR HEATING AIRFLOW										
	WATTS	APPROXIMATELY 40-50% COOLING OR HEATING AIRFLOW										
Cooling - Low	CFM	1857 (1831)	1831 (1802)	1800 (1765)	1766 (1728)	-	-	-	-	-	-	-
	WATTS	515 (524)	523 (533)	533 (545)	544 (558)	-	-	-	-	-	-	-
Cooling - Med	CFM	2031 (2003)	2003 (1975)	1974 (1946)	1940 (1913)	1907 (1880)	1874 (1848)	1837 (1811)	1805 (1780)	1771 (1746)	-	-
	WATTS	594 (611)	609 (627)	624 (642)	639 (658)	653 (672)	667 (686)	681 (701)	695 (715)	709 (730)	-	-
Cooling - High	CFM	2083 (2054)	2058 (2030)	2032 (2010)	2003 (1976)	1974 (1946)	1943 (1911)	1911 (1879)	1877 (1848)	1843 (1817)	1807 (1781)	-
	WATTS	749 (770)	759 (781)	769 (790)	779 (804)	788 (819)	803 (832)	816 (845)	830 (858)	845 (872)	860 (887)	-
Heating - Low	CFM	1534 (1541)	1489 (1497)	1445 (1452)	1403 (1410)	1361 (1367)	1314 (1321)	1275 (1281)	1234 (1240)	-	-	-
	WATTS	281 (282)	292 (293)	304 (305)	314 (316)	325 (327)	337 (339)	348 (349)	358 (360)	-	-	-
Heating - High	CFM	-	1594 (1602)	1551 (1558)	1511 (1518)	1471 (1478)	1430 (1437)	1386 (1392)	1344 (1351)	1305 (1311)	1265 (1271)	-
	WATTS	-	348 (350)	361 (363)	373 (374)	384 (386)	396 (398)	409 (411)	420 (423)	432 (434)	443 (445)	-

Note: Cooling airflow must not exceed 2250 CFM due to condensate blowoff.

4YCC4060E1115		EXTERNAL STATIC PRESSURE (IN.WG) Horizontal Airflow [Down Airflow]										
Motor Speed		0.0	0.1	0.2	0.3	0.4	0.5	0.6	0.7	0.8	0.9	1
Constant Circulation	CFM	APPROXIMATELY 40-50% COOLING OR HEATING AIRFLOW										
	WATTS	APPROXIMATELY 40-50% COOLING OR HEATING AIRFLOW										
Cooling - Low	CFM	1857 (1831)	1831 (1802)	1800 (1765)	1766 (1728)	-	-	-	-	-	-	-
	WATTS	515 (524)	523 (533)	533 (545)	544 (558)	-	-	-	-	-	-	-
Cooling - Med	CFM	2031 (2003)	2003 (1975)	1974 (1946)	1940 (1913)	1907 (1880)	1874 (1848)	1837 (1811)	1805 (1780)	1771 (1746)	-	-
	WATTS	594 (611)	609 (627)	624 (642)	639 (658)	653 (672)	667 (686)	681 (701)	695 (715)	709 (730)	-	-
Cooling - High	CFM	2083 (2054)	2058 (2030)	2032 (2010)	2003 (1976)	1974 (1946)	1943 (1911)	1911 (1879)	1877 (1848)	1843 (1817)	1807 (1781)	-
	WATTS	749 (770)	759 (781)	769 (790)	779 (804)	788 (819)	803 (832)	816 (845)	830 (858)	845 (872)	860 (887)	-
Heating - Low	CFM	1827 (1815)	1792 (1790)	1757 (1757)	1721 (1712)	1685 (1679)	1646 (1648)	1605 (1613)	1570 (1574)	-	-	-
	WATTS	492 (510)	505 (520)	517 (532)	529 (549)	541 (560)	553 (570)	566 (582)	577 (596)	-	-	-
Heating - High	CFM	-	1927 (1910)	1894 (1875)	1861 (1839)	1824 (1803)	1788 (1773)	1750 (1736)	1711 (1704)	1674 (1661)	1639 (1622)	-
	WATTS	-	614 (630)	627 (634)	639 (647)	651 (660)	664 (672)	677 (685)	689 (698)	702 (712)	715 (726)	-

Note: Cooling airflow must not exceed 2250 CFM due to condensate blowoff.

To set indoor motor for the desired speed options, connect the motor leads in the taps as shown below:

Table 2. Motor Wiring: 4YCC4024 - 42, 4YCC4060

MOTOR WIRING	MOTOR TAP				
MODE/SPEED	1	2	3	4	5
CONSTANT CIRCULATION	G (GR)				
COOLING-LOW & HEATING-LOW	G (GR)	Y (YL)		W (PR)	
COOLING-LOW & HEATING-HIGH	G (GR)	Y (YL)			W (PR)
COOLING-MED & HEATING-LOW	G (GR)		Y (YL)	W (PR)	
COOLING-MED & HEATING-HIGH	G (GR)		Y (YL)		W (PR)
COOLING-HIGH & HEATING-LOW	G (GR)			W (PR)	Y (YL)
COOLING-HIGH & HEATING-HIGH	G (GR)			Y (YL)	W (PR)

G signal (GR - green wire), Y signal (YL - yellow wire), W signal (PR - purple wire)

Table 3. Motor Wiring: 4YCC4048

MOTOR WIRING	MOTOR TAP				
MODE/SPEED	1	2	3	4	5
CONSTANT CIRCULATION	G (GR)				
COOLING-LOW & HEATING-LOW	G (GR)	Y (YL)		W (PR)	
COOLING-LOW & HEATING-HIGH	G (GR)	Y (YL)			W (PR)
COOLING-MED LOW& HEATING-LOW	G (GR)		Y (YL)	W (PR)	
COOLING-MED LOW & HEATING-HIGH	G (GR)		Y (YL)		W (PR)
COOLING-MED HIGH & HEATING-LOW	G (GR)	W (PR)		Y (YL)	
COOLING-MED HIGH & HEATING-HIGH	G (GR)		W (PR)	Y (YL)	
COOLING-HIGH & HEATING-LOW	G (GR)	W (PR)			Y (YL)
COOLING-HIGH & HEATING-HIGH	G (GR)		W (PR)		Y (YL)

G signal (GR - green wire), Y signal (YL - yellow wire), W signal (PR - purple wire)

Wiring Diagrams

Figure 1. 4YCC4024-042

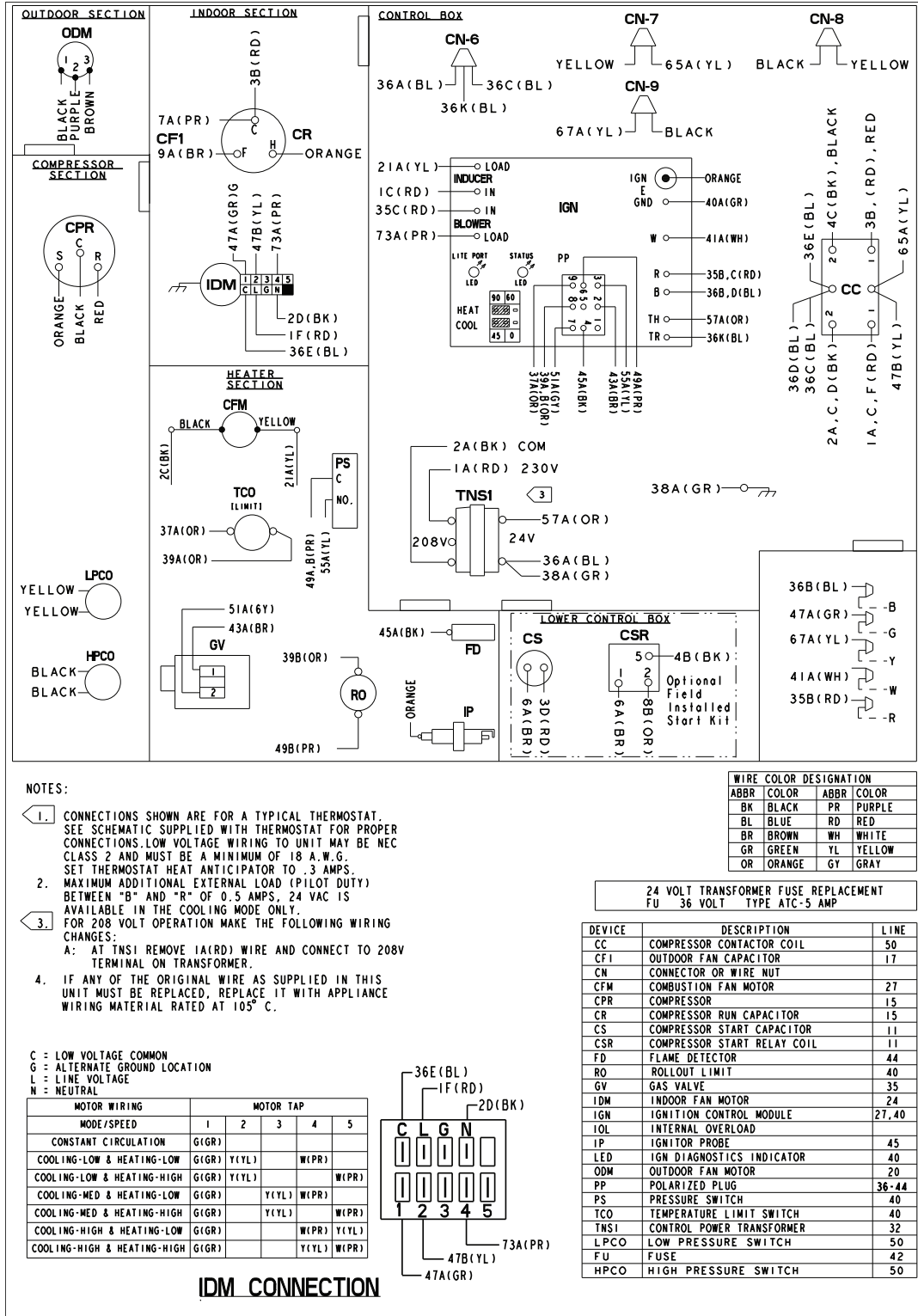

Figure 2. 4YCC4024-042

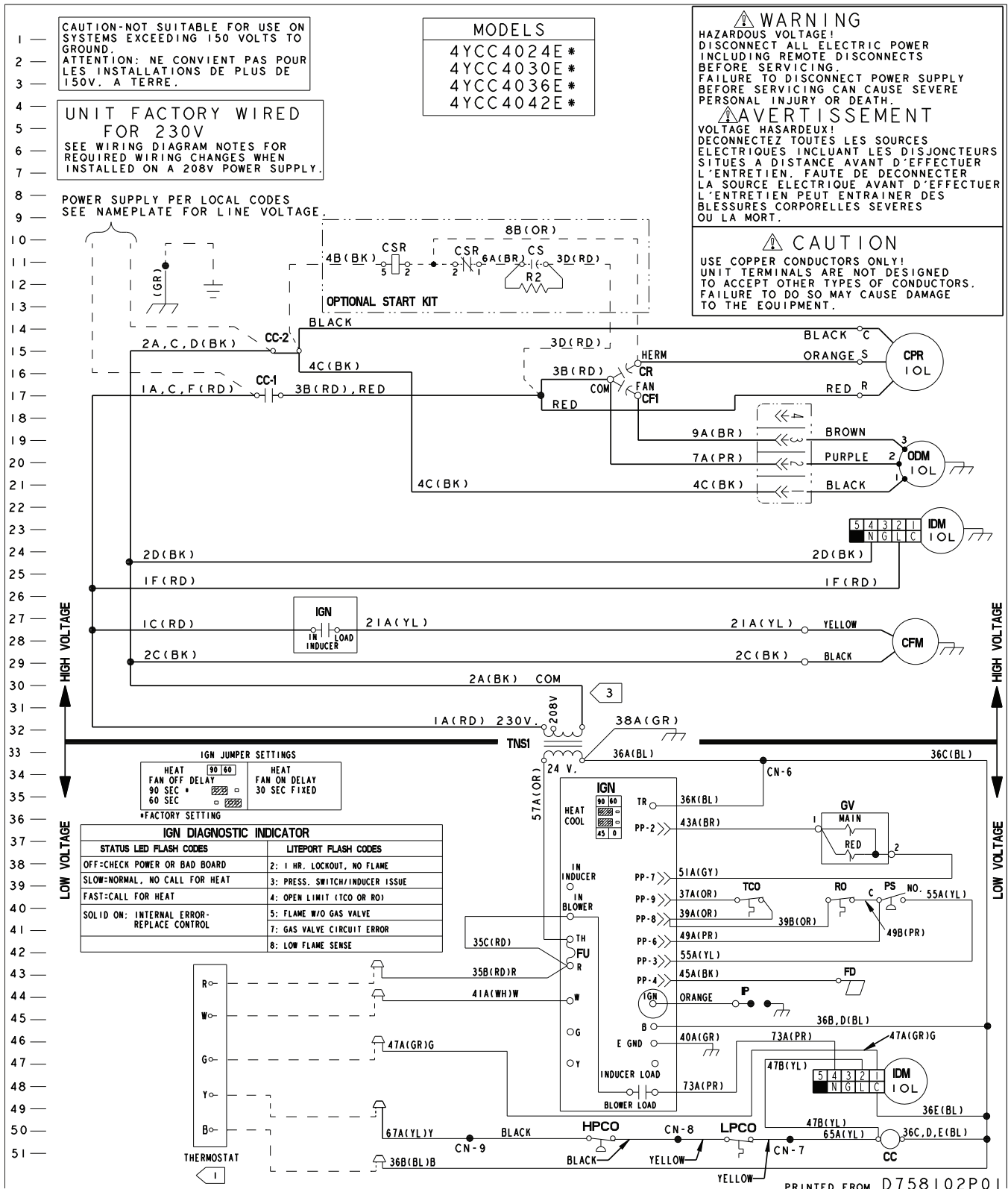
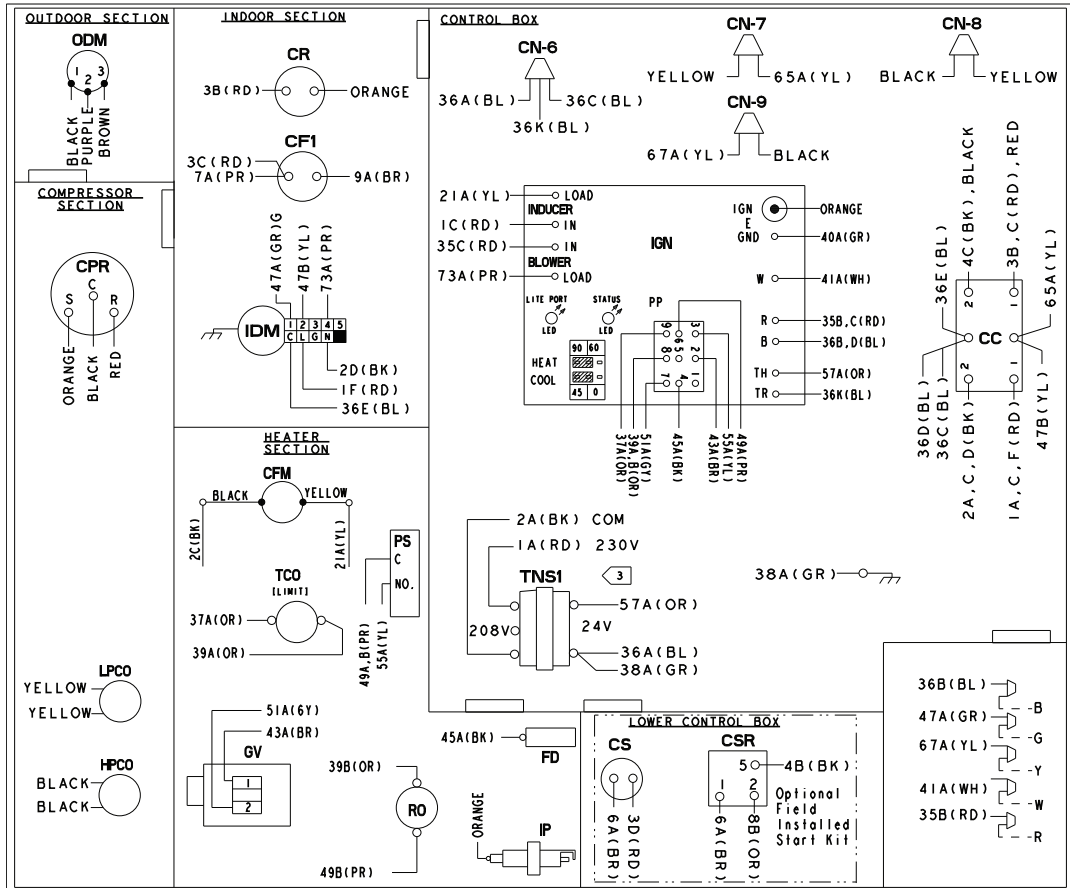

Figure 3. 4YCC4048



NOTES:

- CONNECTIONS SHOWN ARE FOR A TYPICAL THERMOSTAT. SEE SCHEMATIC SUPPLIED WITH THERMOSTAT FOR PROPER CONNECTIONS. LOW VOLTAGE WIRING TO UNIT MAY BE NEC CLASS 2 AND MUST BE A MINIMUM OF 18 A.W.G. SET THERMOSTAT HEAT ANTICIPATOR TO .3 AMPS.
- MAXIMUM ADDITIONAL EXTERNAL LOAD (PILOT DUTY) BETWEEN "B" AND "R" OF 0.5 AMPS, 24 VAC IS AVAILABLE IN THE COOLING MODE ONLY.
- FOR 208 VOLT OPERATION MAKE THE FOLLOWING WIRING CHANGES:
A: AT TNS1 REMOVE 1A(RD) WIRE AND CONNECT TO 208V TERMINAL ON TRANSFORMER.
- IF ANY OF THE ORIGINAL WIRE AS SUPPLIED IN THIS UNIT MUST BE REPLACED, REPLACE IT WITH APPLIANCE WIRING MATERIAL RATED AT 105° C.

C = LOW VOLTAGE COMMON
G = ALTERNATE GROUND LOCATION
L = LINE VOLTAGE
N = NEUTRAL

MOTOR WIRING MODE/SPEED	MOTOR TAP				
	1	2	3	4	5
CONSTANT CIRCULATION	G(GR)				
COOLING-LOW & HEATING-LOW	G(GR)	Y(YL)		W(PR)	
COOLING-MED LOW & HEATING-HIGH	G(GR)	Y(YL)		W(PR)	
COOLING-MED LOW & HEATING-LOW	G(GR)		Y(YL)	W(PR)	
COOLING-MED LOW & HEATING-HIGH	G(GR)		Y(YL)	W(PR)	
COOLING-MED HIGH & HEATING-LOW	G(GR)	W(PR)		Y(YL)	
COOLING-MED HIGH & HEATING-HIGH	G(GR)		W(PR)	Y(YL)	
COOLING-HIGH & HEATING-LOW	G(GR)	W(PR)		Y(YL)	
COOLING-HIGH & HEATING-HIGH	G(GR)		W(PR)	Y(YL)	

IDM CONNECTION

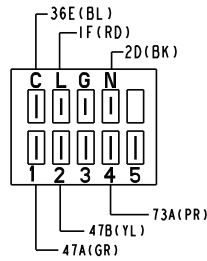

ABBR	COLOR	ABBR	COLOR
BK	BLACK	PR	PURPLE
BL	BLUE	RD	RED
BR	BROWN	WH	WHITE
GR	GREEN	YL	YELLOW
OR	ORANGE	GY	GRAY

24 VOLT TRANSFORMER FUSE REPLACEMENT
FU 36 VOLT TYPE ATC-5 AMP

DEVICE	DESCRIPTION	LINE
CC	COMPRESSOR CONTACTOR COIL	50
CFI	OUTDOOR FAN CAPACITOR	17
CN	CONNECTOR OR WIRE NUT	
CFM	COMBUSTION FAN MOTOR	27
CPR	COMPRESSOR	15
CR	COMPRESSOR RUN CAPACITOR	15
CS	COMPRESSOR START CAPACITOR	11
CSR	COMPRESSOR START RELAY COIL	11
FD	FLAME DETECTOR	44
RO	ROLLOUT LIMIT	40
GV	GAS VALVE	35
IDM	INDOOR FAN MOTOR	24
IGN	IGNITION CONTROL MODULE	27, 40
IOL	INTERNAL OVERLOAD	
IP	IGNITOR PROBE	45
LED	IGN DIAGNOSTICS INDICATOR	40
ODM	OUTDOOR FAN MOTOR	20
PP	POLARIZED PLUG	36-44
PS	PRESSURE SWITCH	40
TCO	TEMPERATURE LIMIT SWITCH	40
TNS1	CONTROL POWER TRANSFORMER	32
LPCO	LOW PRESSURE SWITCH	50
FU	FUSE	42
HPCO	HIGH PRESSURE SWITCH	50

Figure 4. 4YCC4048

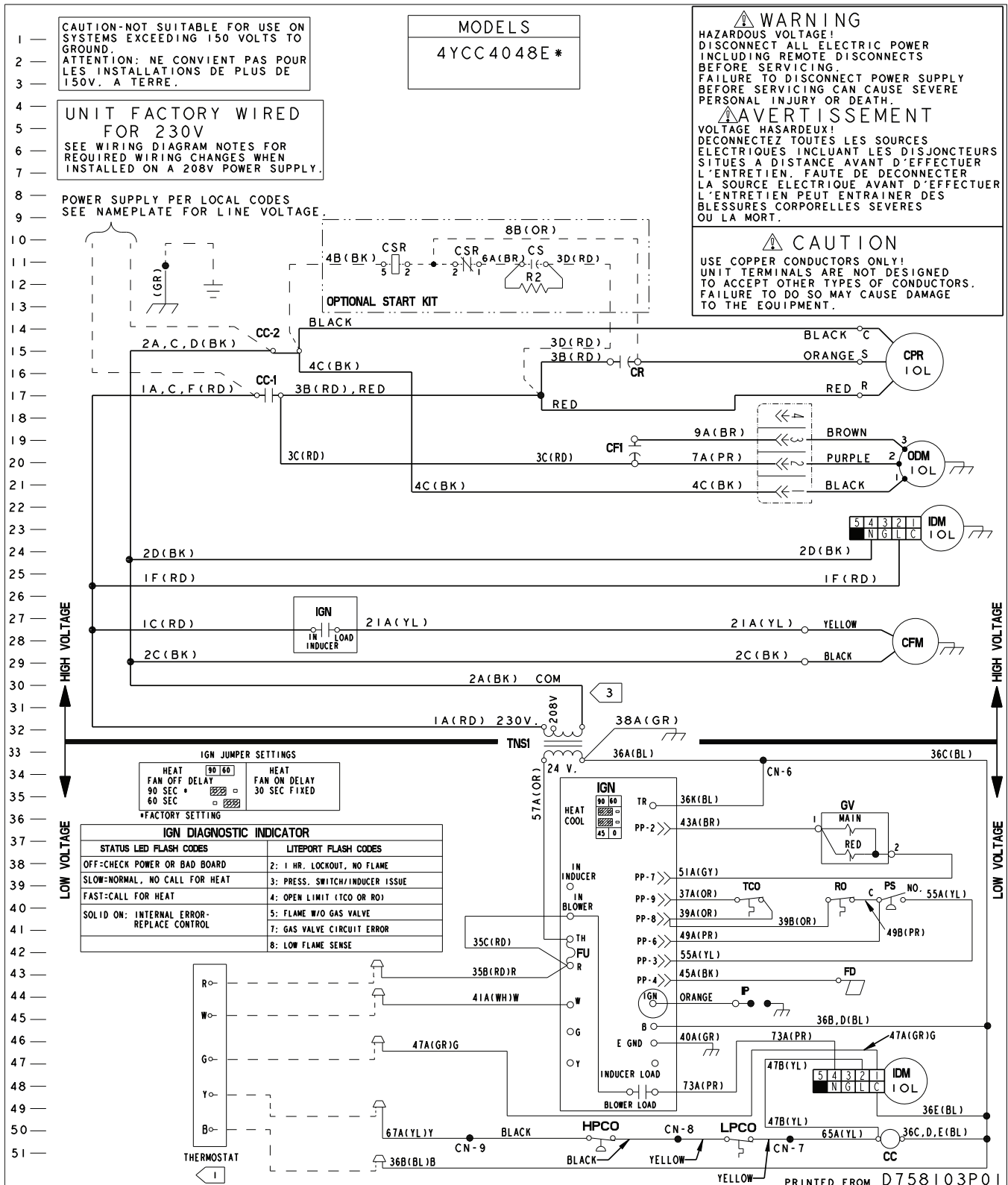
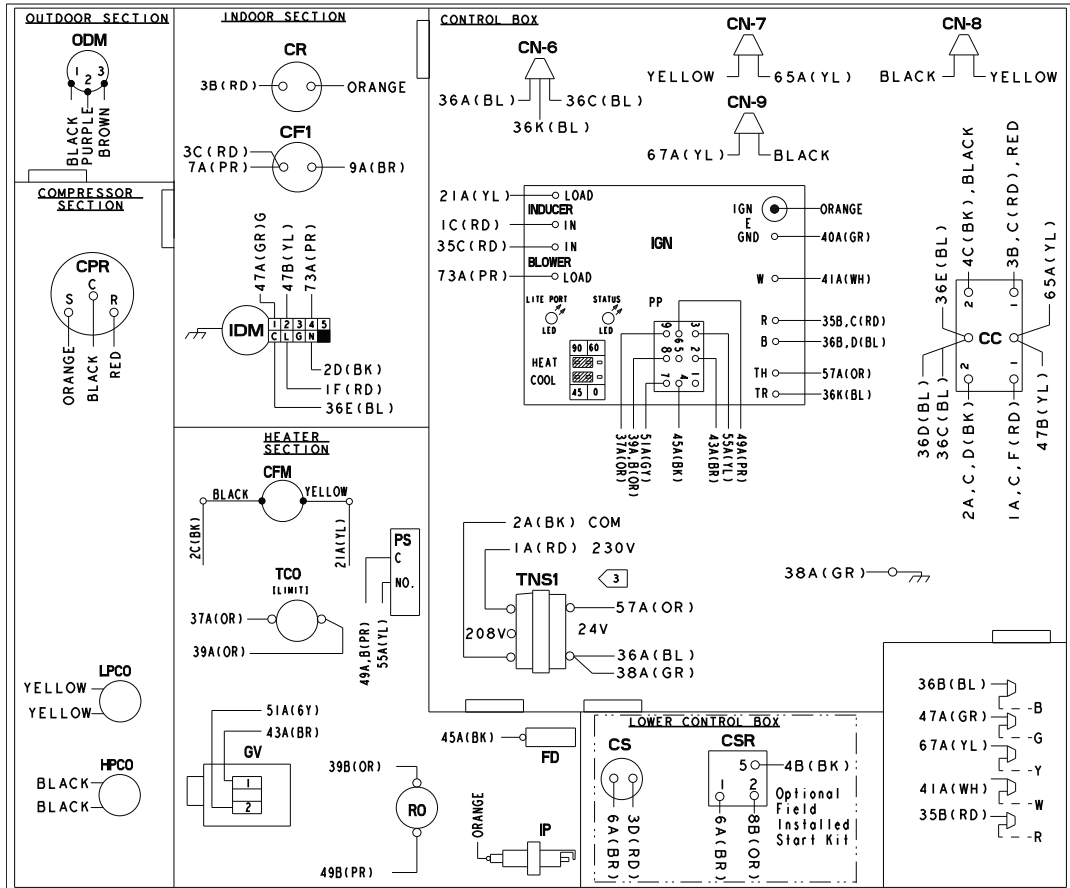

Figure 5. 4YCC4060



NOTES:

- CONNECTIONS SHOWN ARE FOR A TYPICAL THERMOSTAT. SEE SCHEMATIC SUPPLIED WITH THERMOSTAT FOR PROPER CONNECTIONS. LOW VOLTAGE WIRING TO UNIT MAY BE NEC CLASS 2 AND MUST BE A MINIMUM OF 18 A.W.G. SET THERMOSTAT HEAT ANTICIPATOR TO .3 AMPS.
- MAXIMUM ADDITIONAL EXTERNAL LOAD (PILOT DUTY) BETWEEN "B" AND "R" OF 0.5 AMPS, 24 VAC IS AVAILABLE IN THE COOLING MODE ONLY.
- FOR 208 VOLT OPERATION MAKE THE FOLLOWING WIRING CHANGES:
A: AT TNS1 REMOVE 1A(RD) WIRE AND CONNECT TO 208V TERMINAL ON TRANSFORMER.
- IF ANY OF THE ORIGINAL WIRE AS SUPPLIED IN THIS UNIT MUST BE REPLACED, REPLACE IT WITH APPLIANCE WIRING MATERIAL RATED AT 105° C.

C = LOW VOLTAGE COMMON
G = ALTERNATE GROUND LOCATION
L = LINE VOLTAGE
N = NEUTRAL

MODE/SPEED	MOTOR WIRING					MOTOR TAP				
	1	2	3	4	5	1	2	3	4	5
CONSTANT CIRCULATION	G(GR)									
COOLING-LOW & HEATING-LOW	G(GR)	Y(YL)			W(PR)					
COOLING-LOW & HEATING-HIGH	G(GR)	Y(YL)			W(PR)					
COOLING-MED & HEATING-LOW	G(GR)		Y(YL)	W(PR)						
COOLING-MED & HEATING-HIGH	G(GR)		Y(YL)	W(PR)						
COOLING-HIGH & HEATING-LOW	G(GR)			W(PR)	Y(YL)					
COOLING-HIGH & HEATING-HIGH	G(GR)			Y(YL)	W(PR)					

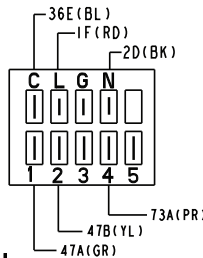

IDM CONNECTION

ABBR	COLOR	ABBR	COLOR
BK	BLACK	PR	PURPLE
BL	BLUE	RD	RED
BR	BROWN	WH	WHITE
GR	GREEN	YL	YELLOW
OR	ORANGE	GY	GRAY

24 VOLT TRANSFORMER FUSE REPLACEMENT
FU 36 VOLT TYPE ATC-5 AMP

DEVICE	DESCRIPTION	LINE
CC	COMPRESSOR CONTACTOR COIL	50
CFI	OUTDOOR FAN CAPACITOR	17
CN	CONNECTOR OR WIRE NUT	
CFM	COMBUSTION FAN MOTOR	27
CPR	COMPRESSOR	15
CR	COMPRESSOR RUN CAPACITOR	15
CS	COMPRESSOR START CAPACITOR	11
CSR	COMPRESSOR START RELAY COIL	11
FD	FLAME DETECTOR	44
RO	ROLLOUT LIMIT	40
GV	GAS VALVE	35
IDM	INDOOR FAN MOTOR	24
IGN	IGNITION CONTROL MODULE	27,40
IOL	INTERNAL OVERLOAD	
IP	IGNITOR PROBE	45
LED	IGN DIAGNOSTICS INDICATOR	40
ODM	OUTDOOR FAN MOTOR	20
PP	POLARIZED PLUG	36-44
PS	PRESSURE SWITCH	40
TCO	TEMPERATURE LIMIT SWITCH	40
TNS1	CONTROL POWER TRANSFORMER	32
LPCO	LOW PRESSURE SWITCH	50
FU	FUSE	42
HPCO	HIGH PRESSURE SWITCH	50

Figure 6. 4YCC4060

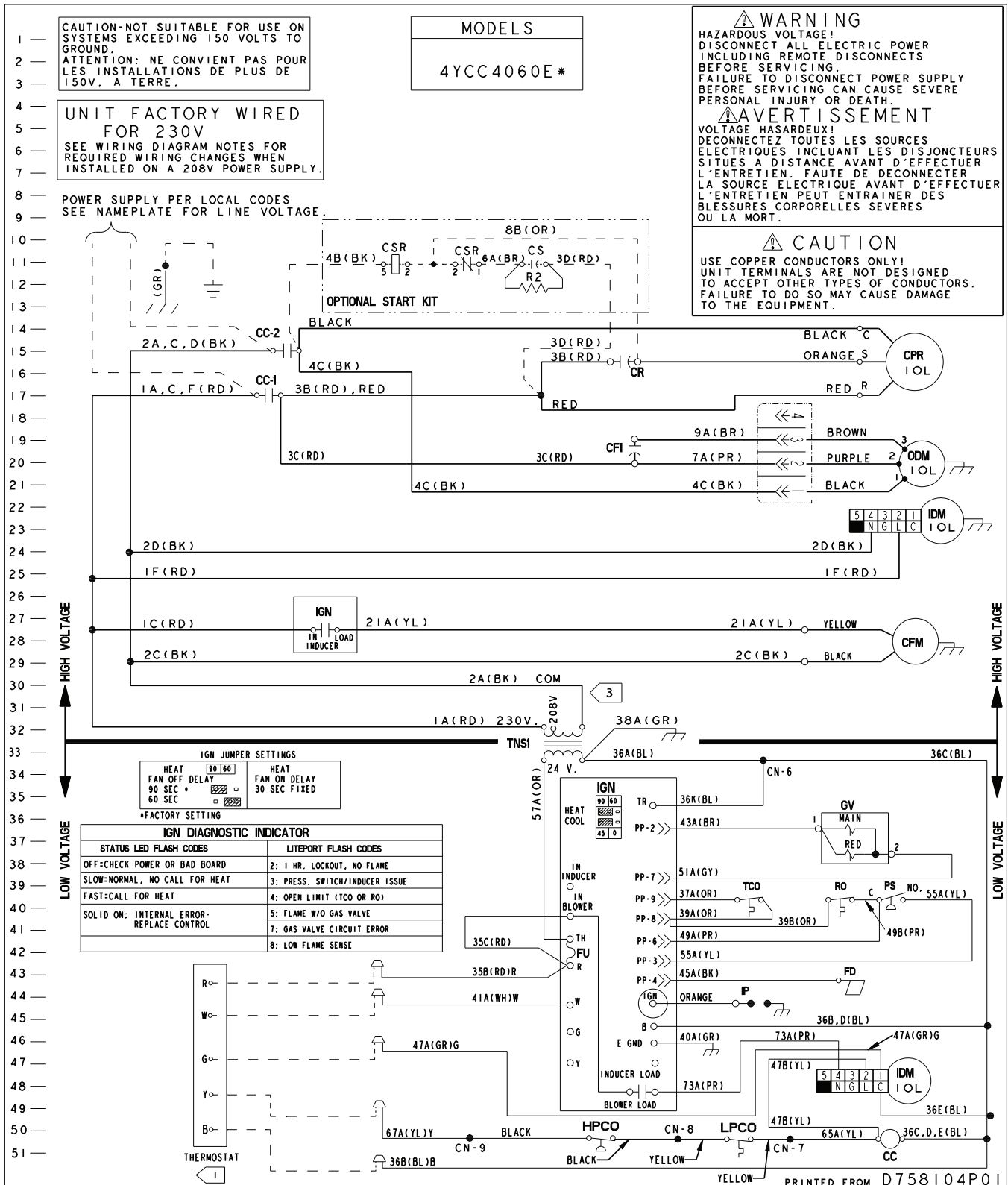

Full Perimeter Roof Mounting Curb

Figure 7. 2.0 – 3.0 Ton Models

BAYCURB050A Full Perimeter Roof Mounting Curb

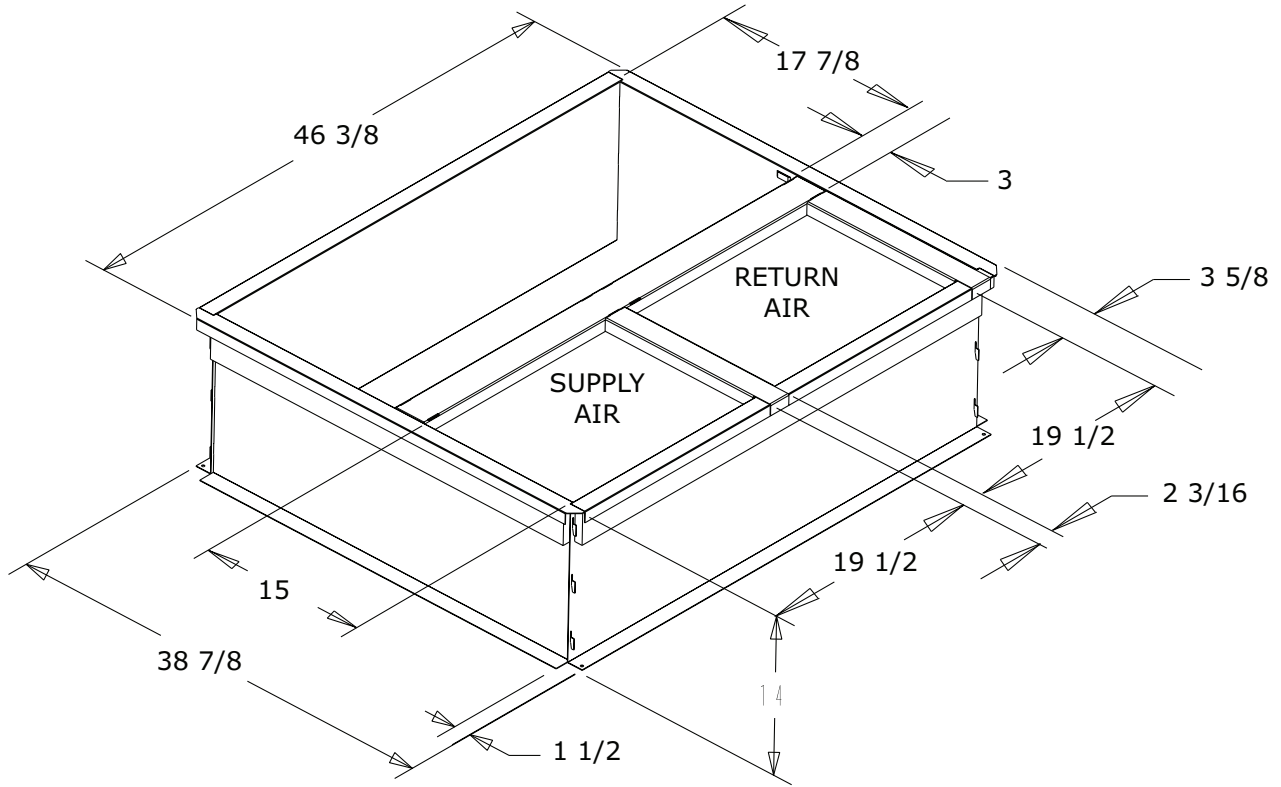

The drawings on this page are prepared by the manufacturer in order to provide detail regarding job layout only. These drawings are not intended to be used as a basis to construct, build or modify the items depicted in the drawings. The manufacturer is not responsible for the unauthorized use of these drawings and expressly disclaims any liability for damages resulting from such unauthorized use.

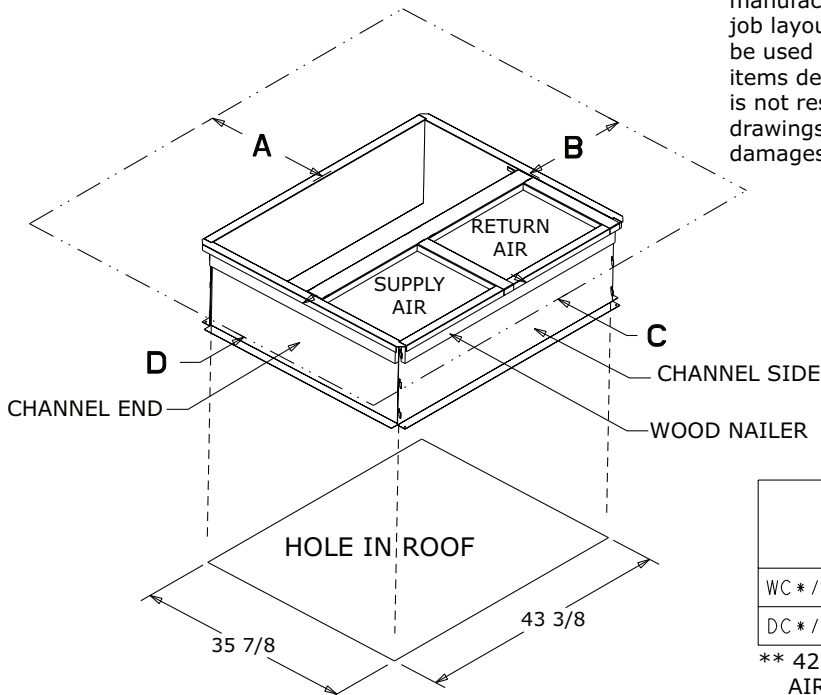

	SERVICE CLEARANCE DIMENSIONS			
	A	B	C	D
WC*/TC*	42.00	36.00	12.00**	24.00
DC*/YC*	42.00	36.00	12.00**	36.00

** 42.00 WITH ECONOMIZER WITH 25% FRESH AIR ACCESSORY

Figure 8. 3.5 – 5.0 Ton Models

BAYCURB051A Full Perimeter Roof Mounting Curb

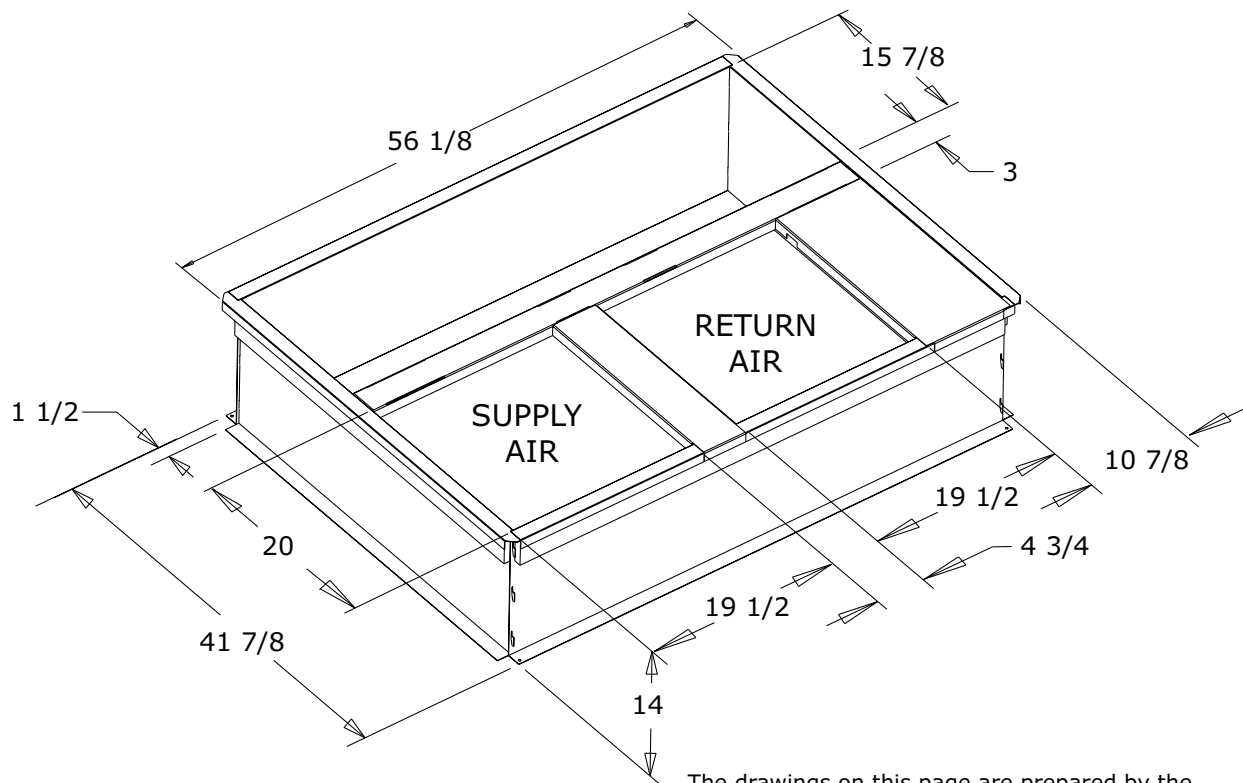

The drawings on this page are prepared by the manufacturer in order to provide detail regarding job layout only. These drawings are not intended to be used as a basis to construct, build or modify the items depicted in the drawings. The manufacturer is not responsible for the unauthorized use of these drawings and expressly disclaims any liability for damages resulting from such unauthorized use.

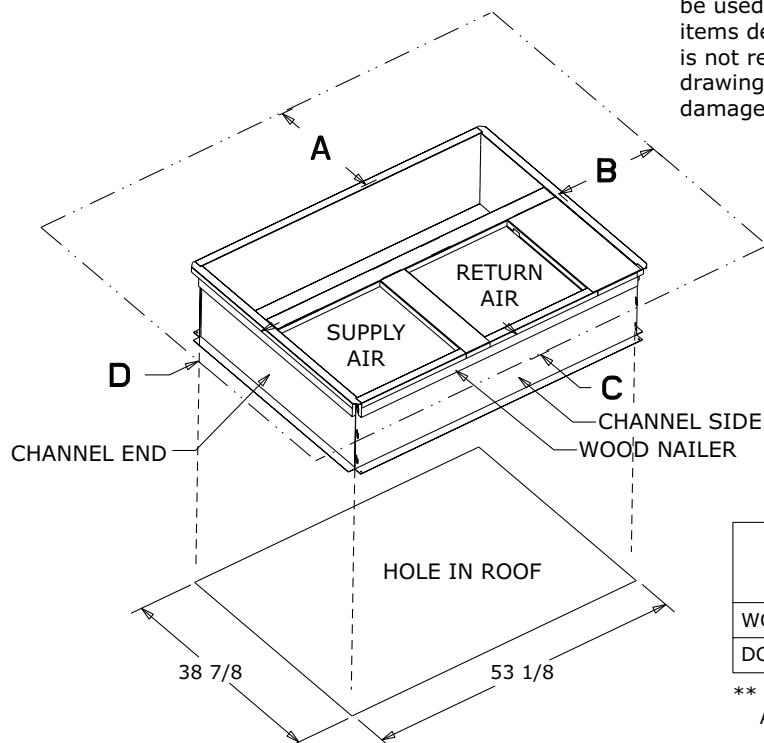

	SERVICE CLEARANCE DIMENSIONS			
	A	B	C	D
WC*/TC*	42.00	36.00	12.00**	24.00
DC*/YC*	42.00	36.00	12.00**	36.00

** 42.00 WITH ECONOMIZER WITH 25% FRESH AIR ACCESSORY

Optional Equipment – Economizer

Table 4. BAYECON101,102A Down Discharge Economizer and Rain Hood (Mounts Over Horizontal Return Air Opening)

	Economizer	Unit Application Models
	BAYECON101A	2.0 – 3.0 Ton Models
	BAYECON102A	3.5 – 5.0 Ton Models

Table 5. BAYCON200, 201A Horizontal Economizer and Rain Hood

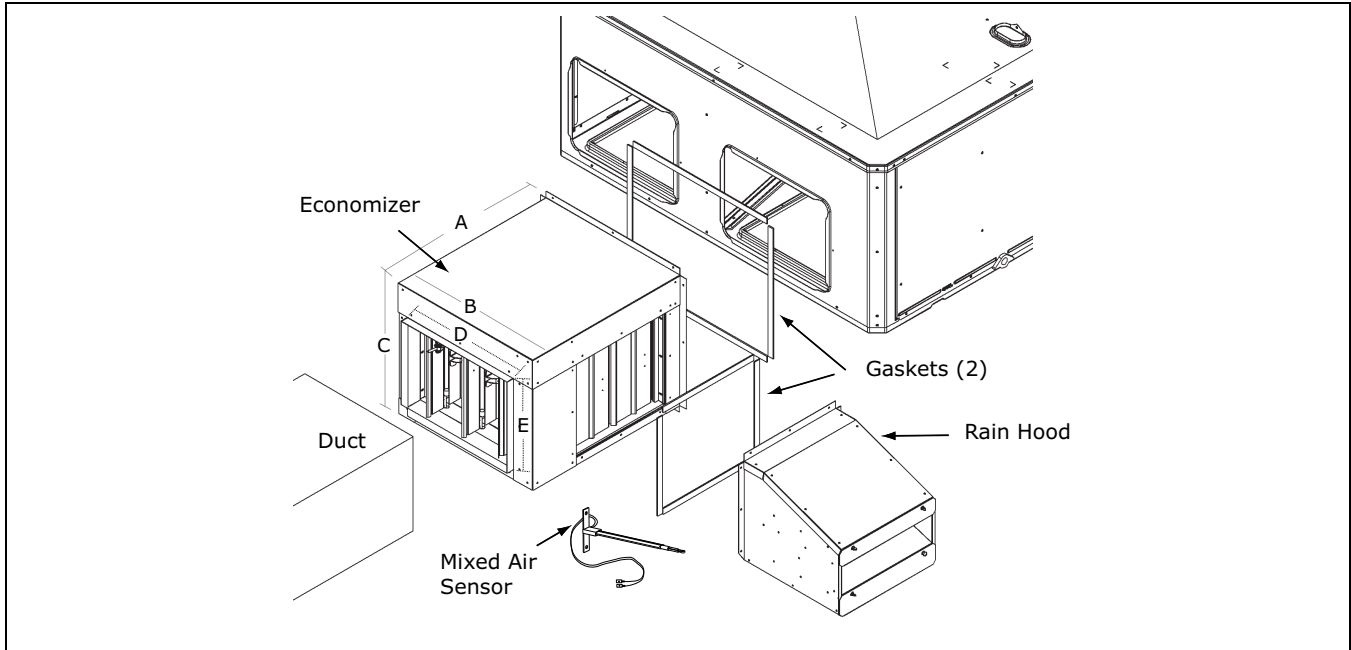

Economizer	Models	A	B	C	D	E	F
BAYECON200A	2.0 – 3.0 Ton	22"	20"	16-7/8"	15-11/16"	11-11/16"	15"
BAYECON201A	3.5 – 5.0 Ton	26"	22-21/32"	19"	17-11/16"	14-11/16"	21-3/8"

Note: The drawings on this page are prepared by the manufacturer in order to provide detail regarding job layout only. These drawings are not intended to be used as a basis to construct, build or modify the items depicted in the drawings. The manufacturer is not responsible for the unauthorized use of these drawings and expressly disclaims any liability for damages resulting from such unauthorized use.



Optional Equipment – Outside Air Damper

**Table 6. BAYOSAH001 and 002A Outside Air Damper
(Replaces Filter/Coil Access Panel)**

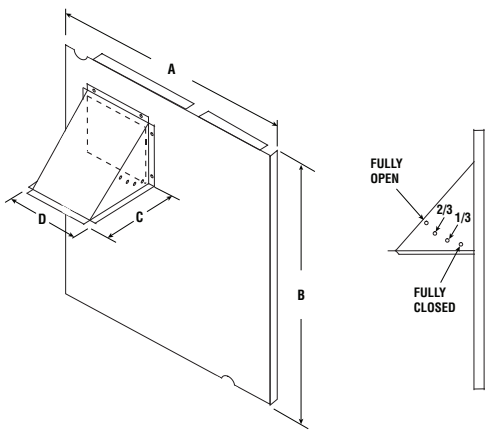
	Manual Fresh Air Model	Unit Application Models	A	B	C	D
	BAYOSAH001A	2.0 – 3.0 Ton	22-7/16"	20-11/16"	12-3/8"	9-3/16"
BAYOSAH002A	3.5 – 5.0 Ton	25-3/16"	20-11/16"	12-3/8"	9-3/16"	

**Table 7. BAYDMPR101 and 102A, 25% Motorized Outside Air Damper
(Mounts Over Horizontal Return Air Opening)**

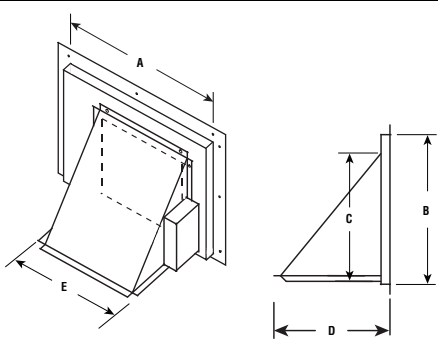
	Manual Fresh Air Model	Unit Application Models	A	B	C	D	E
	BAYDM-PR101A	2.0 – 3.0 Ton	15-13/16"	11-13/16"	10-1/4"	11-1/2"	12-1/4"
BAYDM-PR102A	3.5 – 5.0 Ton	18-3/16"	15-1/8"	10-1/4"	11-1/2"	12-1/4"	

Note: The drawings on this page are prepared by the manufacturer in order to provide detail regarding job layout only. These drawings are not intended to be used as a basis to construct, build or modify the items depicted in the drawings. The manufacturer is not responsible for the unauthorized use of these drawings and expressly disclaims any liability for damages resulting from such unauthorized use.



Optional Equipment — Filter Rack

**Figure 9. BAYFLTR101 Filter Rack (2.0 – 3.0 Ton Models)
BAYFLTR201 (3.5 – 5.0 Ton Models)
(Mounts in Filter/Coil Section)**

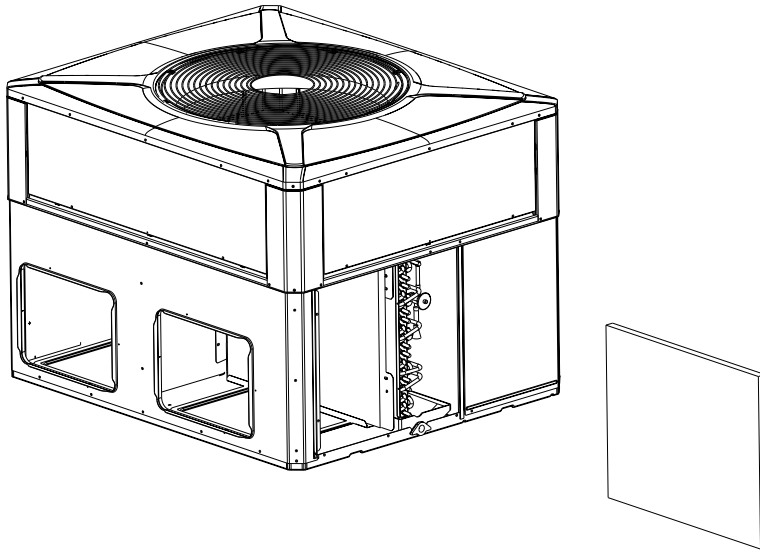

**Figure 10. BAYACCDOR1A Hinged Filter Access Door (2.0 – 3.0 Ton Models)
BAYACCDOR2A (3.5 – 5.0 Ton Models)
Replaces Filter/Coil Access Panel**

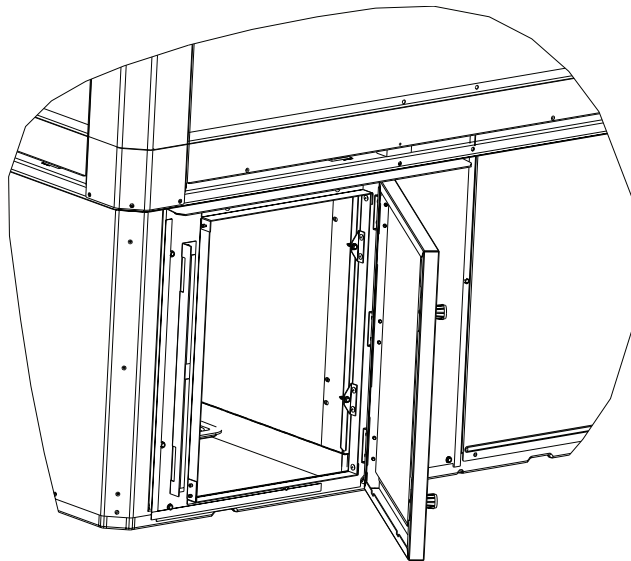

Note: The drawings on this page are prepared by the manufacturer in order to provide detail regarding job layout only. These drawings are not intended to be used as a basis to construct, build or modify the items depicted in the drawings. The manufacturer is not responsible for the unauthorized use of these drawings and expressly disclaims any liability for damages resulting from such unauthorized use.

Outline Drawings

Figure 11. 2 - 5 Ton Models

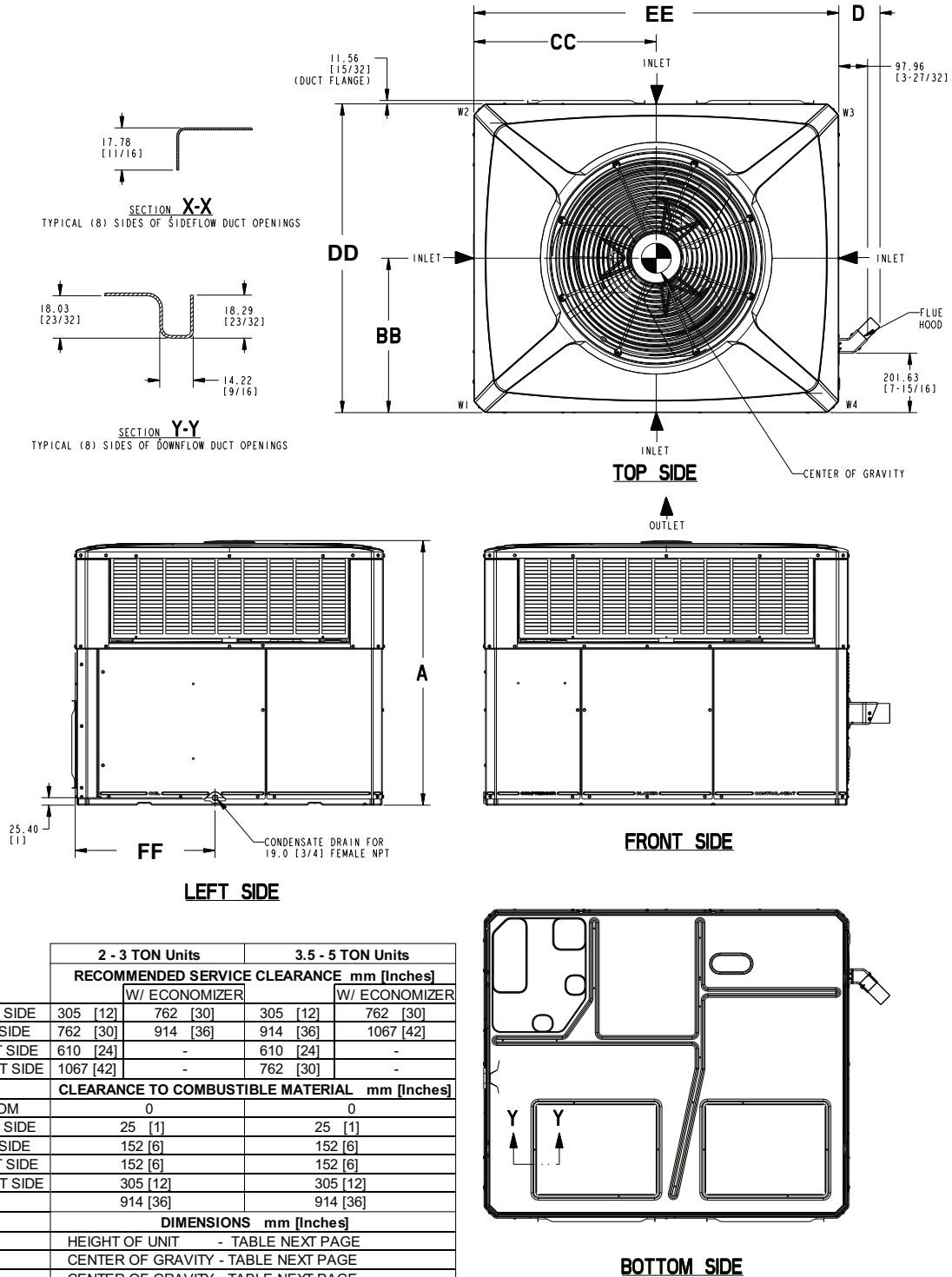

	2 - 3 TON Units		3.5 - 5 TON Units	
	RECOMMENDED SERVICE CLEARANCE mm [Inches]			
	W/ ECONOMIZER		W/ ECONOMIZER	
BACK SIDE	305 [12]	762 [30]	305 [12]	762 [30]
LEFT SIDE	762 [30]	914 [36]	914 [36]	1067 [42]
RIGHT SIDE	610 [24]	-	610 [24]	-
FRONT SIDE	1067 [42]	-	762 [30]	-
CLEARANCE TO COMBUSTIBLE MATERIAL mm [Inches]				
BOTTOM	0		0	
BACK SIDE	25 [1]		25 [1]	
LEFT SIDE	152 [6]		152 [6]	
RIGHT SIDE	152 [6]		152 [6]	
FRONT SIDE	305 [12]		305 [12]	
TOP	914 [36]		914 [36]	
DIMENSIONS mm [Inches]				
A	HEIGHT OF UNIT - TABLE NEXT PAGE			
BB	CENTER OF GRAVITY - TABLE NEXT PAGE			
CC	CENTER OF GRAVITY - TABLE NEXT PAGE			
DD -Depth	1049.02 [41-5/16]		1125.22 [44-5/16]	
EE -Width	1240.28 [48.27-27/32]		1487.17 [58-9/16]	
FF	475.23 [18-23/32]		551.43 [21-23/32]	
	2 - 3 TON		3.5 - 5 TON	

Note: The view labeled "Bottom side" represents the base as viewed looking up from underneath the unit.

Figure 12. 2 - 5 Ton Models

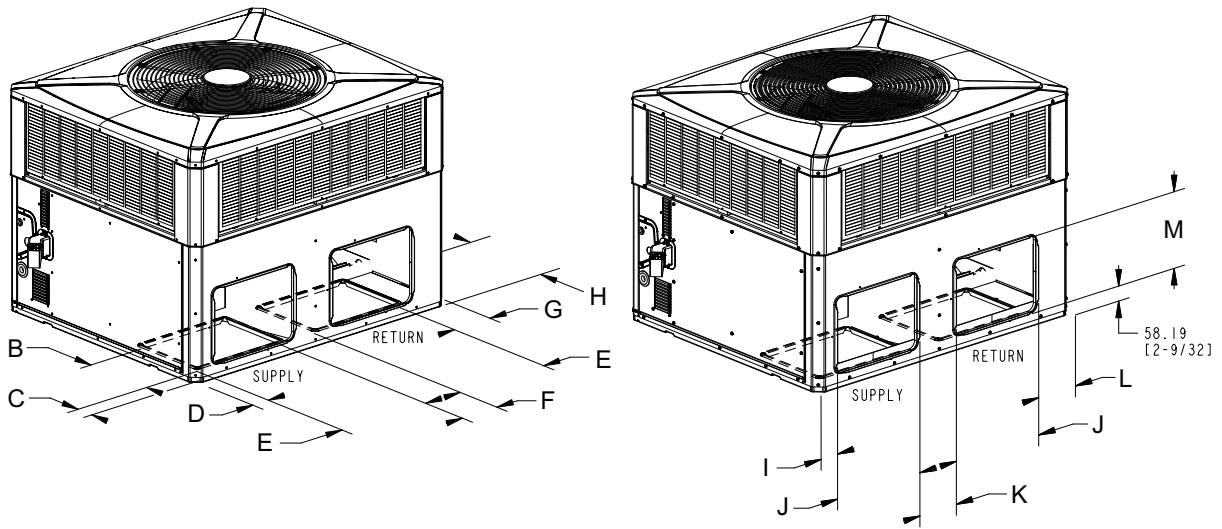

BOTTOM DUCT OPENINGS

BACK DUCT OPENINGS

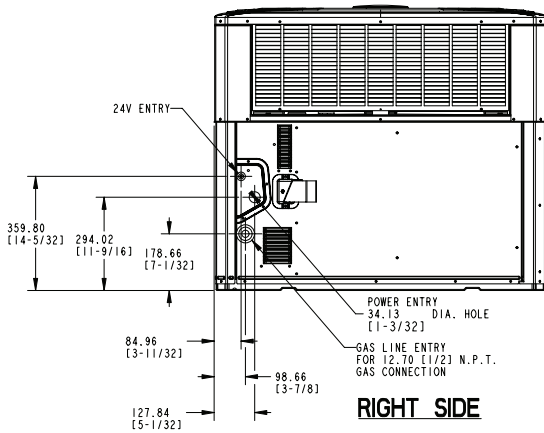

RIGHT SIDE

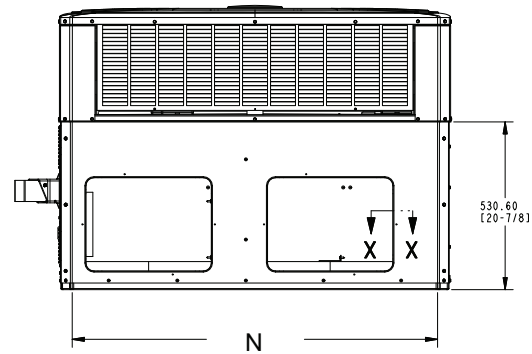

BACK SIDE

PHYSICAL DIMENSIONS mm[in]														
HEIGHT-A mm[inch]	B	C	D	E	F	G	H	I	J	K	L	M	N	
4YCC4024	898.53 [35-3/8]	304.80	75.41	75.41	406.40	167.89	173.46	304.80	79.50	398.22	176.07	177.55	296.62	1155.45
4YCC4030	949.33 [37-3/8]	[12]	[2.93]	[2.93]	[16]	[6.61]	[6-27/32]	[12]	[3.13]	[15.68]	[6.93]	[6.99]	[11.68]	[45.49]
4YCC4036														
4YCC4042	898.53 [35-3/8]	457.20	75.41	75.41	381.00	244.09	318.75	381.00	79.50	449.02	176.07	322.84	372.82	1402.34
4YCC4048		[18]	[2.97]	[2.97]	[15]	[9.61]	[12.55]	[15]	[3.13]	[17.68]	[6.93]	[12.71]	[14.68]	[55.21]
4YCC4060	1000.13 [35-3/8]													

	Corner Weights KG/LBS				SHIPPING WEIGHT KG/LBS	UNIT WEIGHT KG/LBS	Center Of Gravity mm[inch]	
	W1	W2	W3	W4			BB	CC
4YCC4024* (060)	58 [129]	37 [81]	26 [58]	41 [90]	196 [432]	162 [358]	480 [19]	528 [21]
4YCC4030* (070)	61 [135]	39 [85]	28 [61]	43 [95]	205 [451]	171 [377]	407 [16]	594 [23]
4YCC4036* (070)	61 [134]	39 [84]	28 [60]	43 [95]	205 [438]	171 [374]	407 [16]	594 [28]
4YCC4036* (090)	61 [136]	39 [86]	28 [61]	43 [96]	205 [453]	171 [379]	407 [16]	594 [28]
4YCC4042*(060)	71 [157]	47 [103]	35 [76]	53 [117]	252 [555]	202 [202]	470 [19]	731 [29]
4YCC4042*(090)	72 [158]	47 [104]	35 [78]	54 [118]	255 [561]	207 [202]	470 [19]	731 [29]
4YCC4048*(070)	71 [157]	45 [98]	33 [73]	54 [119]	250 [552]	202 [448]	433 [17]	743 [29]
4YCC4048*(090)	72 [159]	45 [99]	34 [75]	55 [120]	253 [557]	205 [453]	433 [17]	743 [29]
4YCC4060*(090)	77 [170]	46 [101]	35 [76]	58 [128]	263 [580]	216 [476]	433 [17]	743 [29]
4YCC4060*(115)	78 [172]	46 [102]	35 [77]	59 [130]	266 [586]	219 [482]	414 [16]	635 [25]



Trane - by Trane Technologies (NYSE: TT), a global innovator - creates comfortable, energy efficient indoor environments for commercial and residential applications. For more information, please visit trane.com or tranetechnologies.com.



The AHRI Certified mark indicates Trane U.S. Inc. participation in the AHRI Certification program. For verification of individual certified products, go to ahridirectory.org.

Trane has a policy of continuous data improvement and it reserves the right to change design and specifications without notice. We are committed to using environmentally conscious print practices.