



FIRST CO.  
P.O. BOX 270969 - DALLAS, TEXAS 75227  
PH. (214) 388-5751 | FAX (214) 388-2255  
WWW.FIRSTCO.COM

# UC Series

Wall / Closet Air Handlers

1.5 - 3.0 Tons **Cooling or Heat Pump**

Up to 10 kW **Electric Heat**

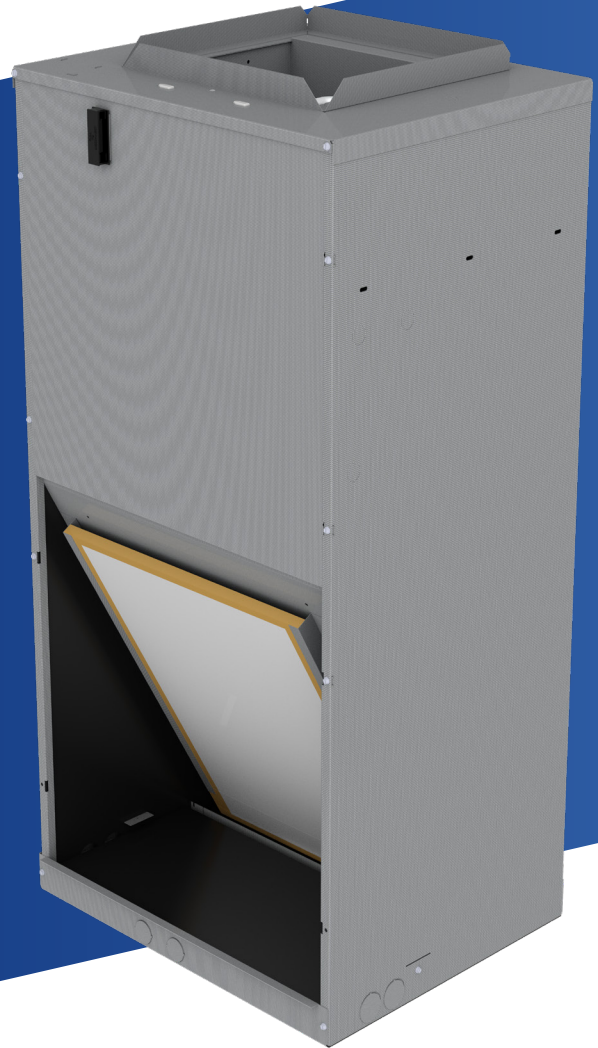

# UC Series

The **UC** series is designed as an upflow indoor air handler for use with today's higher efficiency split-system heat pumps or condensing units.

The cabinet is made of galvanized steel and is fully insulated. The condensate pan is sloped to ensure proper drainage. For installation flexibility, drain piping can come from the bottom, front, left, or right side of the cabinet.

**New Feature:** - The removable door of the optional wall panel now includes "captive screws" that won't fall out when the door is removed for service or filter change.

## STANDARD FEATURES:

- 240V motor, 24V controls
- Factory installed disconnect
- Factory or field installed electric heat on HK units only
- Separate compartment for drain connections
- Drain pan has 3/4" male or female primary and secondary fittings
- High efficiency cooling coil
- Convenient equalizer connection for factory or field installed R410A TXV's (non-bleed type)
- Easily accessible 1" filter
- **Cabinet air leakage is no more than 2% when tested in accordance with ASHRAE 193.**



Unit shown with optional bottom return air kit

## OPTIONAL FEATURES:

Optional accessories include field installed Heater Kits, factory or field installed TXV Kits (non-bleed type), Wall Panels with Captive Screws, Condensate Overflow Switch, Closet Hanger Bracket Kit, and Bottom Return Air Kit

*First Co's customer is ultimately responsible for confirming which fan coil models are compatible with selected outdoor unit(s) and which expansion valves (if any) are required. To determine certified indoor/outdoor combinations, go to [www.firstco.com](http://www.firstco.com) or contact the factory.*



# UC Series

(See P. 3 for Model Numbers)

BLOWER DATA							
MODEL	MOTOR (HP) (240V)	FAN SPEED	CFM VS. EXTERNAL STATIC PRESSURE				
			0.10	0.20	0.30	0.40	0.50
18UC	1/6	HIGH	880	840	810	790	760
		MEDIUM	660	640	630	600	570
		LOW	540	520	500	470	440
19UC	1/6	HIGH	850	820	780	750	710
		MEDIUM	660	640	610	570	540
		LOW	540	520	500	470	430
20UC	1/6	HIGH	840	800	760	710	660
		MEDIUM	660	640	610	570	530
		LOW	540	510	500	460	420
24UC	1/6	HIGH	870	840	810	780	750
		MEDIUM	670	650	630	590	560
		LOW	560	540	510	480	440
25UC	1/6	HIGH	840	800	760	710	670
		MEDIUM	660	640	620	590	550
		LOW	550	530	490	460	430
26UC	1/6	HIGH	860	830	790	740	690
		MEDIUM	670	650	630	590	550
		LOW	550	530	500	470	440
30UC		HIGH	1080	1045	1030	975	920
		MEDIUM	950	940	910	865	820
		LOW	865	855	825	790	745
31UC	1/4	HIGH	910	880	840	790	740
		MED-HIGH	860	830	790	740	690
		MED-LOW	830	790	750	710	660
32UC	1/4	MED-HIGH	1080	1040	1000	950	900
		MED-LOW	970	940	900	850	800
		LOW	690	650	600	550	510
36UC	1/4	HIGH	1300	1240	1180	1120	1050
		MED-HIGH	1100	1050	1010	960	910
		MED-LOW	980	950	920	880	830
37UC	1/4	HIGH	1240	1180	1120	1070	1020
		MED-HIGH	1080	1040	1000	960	910
		MED-LOW	980	950	910	870	820
38UC	1/2	HIGH	1430	1400	1370	1340	1290
		MED-HIGH	1260	1230	1200	1180	1160
		MED-LOW	1000	990	980	970	950

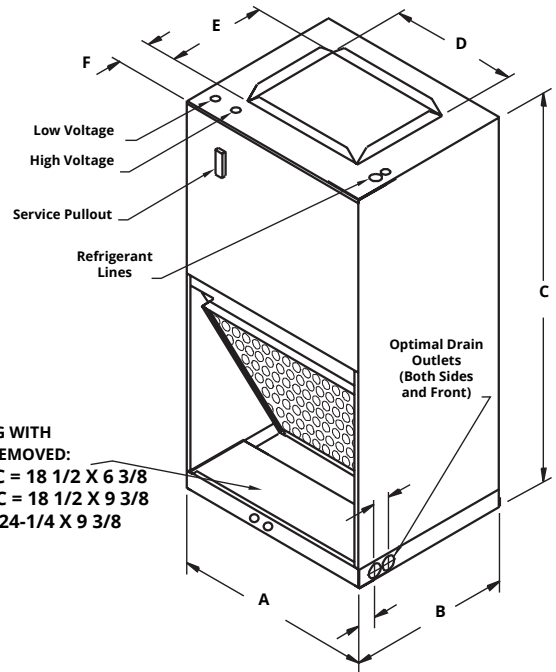

PHYSICAL DIMENSIONS									
UNIT MODEL	A	B	C	D	E	F	FILTER SIZE	LIQUID LINE	SUCTION LINE
18-25UC	22-1/8	15-1/8	40	14	10.5	3-5/8	18 X 18	3/8 O.D.	5/8 O.D.
26/30/31UC	22-1/8	15-1/8	40	14	10.5	3-5/8	18 X 20	3/8 O.D.	3/4 O.D.
32/37UC	22-1/8	18-1/8	43	14	13	3-5/8	18 X 24	3/8 O.D.	3/4 O.D.
38UC	28-1/8	21	46	16-1/2	13	7-1/2	24 x 24	3/8 O.D.	7/8 O.D.

**NOTES:**

1. Coil connections are sweat

**NOTES:**

1. Add nominal .05 static if wall panel is used.
2. ALL models have multi-speed motors but are factory wired on the shaded speeds.
3. Contact factory for correct matches with outdoor units.
4. Approved for installation with "0" clearance to combustible material.

PERFORMANCE DATA													
UNIT MODEL	NOM. CFM	NOM. COOL. BTUH	ELECTRIC HEAT CAPACITY				TOTAL AMPS		MIN. AMPACITY		MAX. OVERCURRENT PROTECTION		
			KW		BTUH		240V	208V	240V	208V	240V	208V	
			240V	208V	240V	208V							
18UC 19UC 20UC	0-HK	600	18000	0	0	0	0	1.70	1.70	2	2	15	15
	3			3	2.3	10239	7781	14	12.76	18	16	20	20
	5			5	3.8	17065	12969	23	19.97	28	26	30	30
24UC 25UC 26UC	6	800	25000	6	4.5	20478	15358	27	23.34	33	29	35	30
	8			8	6.0	27304	20750	35	30.55	44	38	45	40
	10			10	7.5	34130	25597	43	37.76	54	47	60	50
	0-HK			3	0	0	0	2.0	2.0	3	3	15	15
31UC 30UC 32UC	3	1000	30000	3	2.3	10239	7781	15	15	18	16	20	20
	5			5	3.8	17065	12969	23	20	29	26	30	30
	6			6	4.5	20478	15358	27	24	34	30	35	30
36UC 37UC 38UC	8	1200	36000	8	6.0	27304	20750	35	31	44	39	45	40
	10			10	7.5	34130	25597	44	38	55	48	60	50

**NOTES:**

1. 0 - 10 kW is available for ALL UC models  
Model number example - 18UC5 (1.5 Ton, 5kW)



In keeping with its policy of continuous progress and product improvement, First Co. Reserves the right to make changes without notice. Maintenance for all First Co. products is available under "Product Maintenance" at www.firstco.com.

# UC Series

MODEL NUMBERS:		FACTORY INSTALLED TXV'S
MODEL SIZE (BTU)	MODEL (PISTON)	MODEL (R410A TXV)
18,000	18UC( )	18UC( ) R410 TXV
18,000	19UC( )	19UC( ) R410 TXV
18,000	20UC( )	20UC( ) R410 TXV
24,000	24UC( )	24UC( ) R410 TXV
24,000	25UC( )	25UC( ) R410 TXV
24,000	26UC( )	26UC( ) R410 TXV
30,000	31/30UC( )	31UC( ) R410 TXV
30,000	32UC( )	32UC( ) R410 TXV
36,000	36UC( )	36UC( ) R410 TXV
36,000	37UC( )	37UC( ) R410 TXV
36,000	38UC( )	38UC( ) R410 TXV

**All TXV's are approved for cooling only or heat pump operation (non-bleed type).**

**( ) = kW HEAT (0-HK = NO HEAT)**

NOTE:

Expansion valve requirement depends on the selected outdoor unit.  
Go to: [www.firstco.com](http://www.firstco.com) or contact the factory for assistance.

(See P. 4 for Optional Accessories)



# UC Series Accessories

OPTIONAL ACCESSORIES (ALL FIELD INSTALLED)					
DESCRIPTION	PART #			DIMENSIONS	
	18-31UC	32-37UC	38UC	(OUTSIDE FRAME)	(INSIDE FRAME)
WALL PANEL (1)	9PWUC01L (louvered) 9PWUC01S (solid)	9PWUC02L (louvered) 9PWUC02S (solid)	9PWUC04L (louvered) 9PWUC04S (solid)	43-3/8 X 25-5/8	40-3/8 X 22-5/8
				46-3/8 X 25-5/8	43-3/8 X 22-5/8
				52-1/2 X 31-5/8	49-1/2 X 28-5/8
HANGER BRKT SET	90PK3	90PK3	90PK31	1-3/4 X 22-1/8 1-3/4 X 27-15/16	---
BOTTOM RETURN AIR KIT	90PK4	90PK5	90PK51	19-13/16 X 22 20-7/16 X 22 20-5/8 X 28	---
3kW HEATER KIT (2)	9EHUC1-203 (2)	9EHUC2-203 (2)	9EHUC2-203 (2)	---	---
5kW HEATER KIT (2)	9EHUC1-205 (2)	9EHUC2-205 (2)	9EHUC2-205 (2)		
6kW HEATER KIT (2)	9EHUC1-206 (2)	9EHUC2-206 (2)	9EHUC2-206 (2)		
8kW HEATER KIT (2)	9EHUC1-208 (2)	9EHUC2-208 (2)	9EHUC2-208 (2)		
10kW HEATER KIT (2)	9EHUC1-210 (2)	9EHUC2-210 (2)	9EHUC2-210 (2)		
CONDENSATE OVERFLOW KIT	SS3	SS3	SS3	---	---



**Optional wall panel**  
Recessed wall application

**NOTES:**

- Dimensions for wall panels are the outside of the panels. Inside "Opening" dimensions are approximately 3" less than shown.
- Heater kits are only approved for installation in the "0-HK" models. Heater kits are not approved for UC units that already contain factory installed heaters.



**Condensate drain connections**  
(With drain cover removed)  
(Male connections shown)



Condensate Overflow Switch #SS3

EXPANSION VALVE KITS (Heat Pump or Cooling Only) (FIELD INSTALLED)		
PART NO.	TYPE	FOR
9EVR410-1	R-410A	12 - 38UCX-HW (1-1/2 - 3 TON)

**NOTES:**

- Expansion valve kits are approved for both cooling only (non heat pump) or heat pump applications.
- Valves are non-bleed type.
- Valves mount inside unit cabinet



**Unit shown with optional  
bottom return air kit**



FIRST CO.  
P.O. BOX 270969 - DALLAS, TEXAS 75227  
PH. (214) 388-5751 | SALES@FIRSTCO.COM  
WWW.FIRSTCO.COM