



BRADFORD WHITE[®]
W A T E R H E A T E R S

**RESIDENTIAL AND LIGHT DUTY
ELECTRIC WATER HEATER
WITH HEAT PUMP BACK UP
REPLACEMENT PARTS LIST**



**Models Covered:
RE2H50S*-1NCTT
RE2H65T*-1NCTT
RE2H80T*-1NCTT
*Denotes warranty year**

***Effective: December, 2022
ECO 8424-2***

**NOTE: BOTH MODEL AND SERIAL
NUMBERS ARE REQUIRED FOR
ORDERING REPLACEMENT PARTS**

Dimensions and specifications
subject to change without notice.

WARNING
CANCER AND REPRODUCTIVE HARM
WWW.P65WARNINGS.CA.GOV

As required by the state of California Proposition 65.

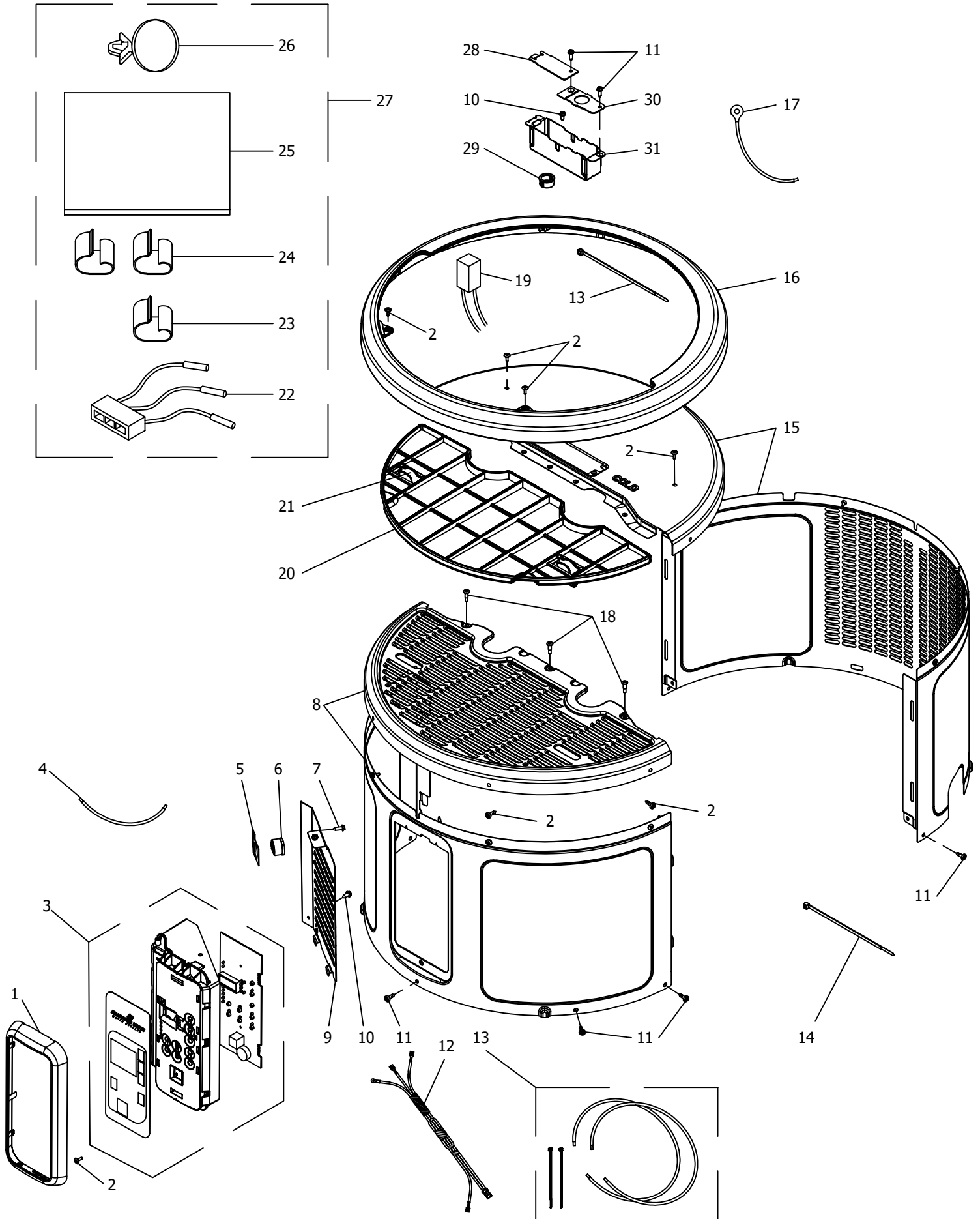

Item Description	Model RE2H50S*	Model RE2H65T*	Model RE2H80T*
1 BEZEL-CONTROL BOARD	235-52319-00	235-52319-00	235-52319-00
2 SCREW-#8-18 AB PNT20 7/16 S (x13)	415-52241-00 WS02X10083	415-52241-00 WS02X10083	415-52241-00 WS02X10083
3 KIT-CONTROL & NT4 OVERLAY	415-54518-00	415-54518-00	415-54518-00
4 WIRE-JUMPER CONTROL BOARD YELLOW 6"	415-52199-00 WS19X10033	415-52199-00 WS19X10033	415-52199-00 WS19X10033
5 BRACKET-OVERLOAD	415-52385-00 WS28X10075	415-52385-00 WS28X10075	415-52385-00 WS28X10075
6 SENSOR-CONTROL BOARD OVERLOAD	415-52419-00 WS08X20363	415-52419-00 WS08X20363	415-52419-00 WS08X20363
7 SCREW-#10-32 GX HXWS 9/16 S	415-52240-00 WZ04X10001	415-52240-00 WZ04X10001	415-52240-00 WZ04X10001
8 KIT-FRONT SHROUD (GREY)	415-52750-00 WS35X20524	415-52750-00 WS35X20524	415-52750-00 WS35X20524
9 ENCLOSURE-CONTROL BOARD	415-52349-00 WS31X20384	415-52349-00 WS31X20384	415-52349-00 WS31X20384
10 SCREW-#10-32 GX HXW 7/16 S (x5)	415-52244-00 WS02X10087	415-52244-00 WS02X10087	415-52244-00 WS02X10087
11 SCREW-#10-32 GX PNT25 1/2 S (x13)	415-52399-00 WS02X10086	415-52399-00 WS02X10086	415-52399-00 WS02X10086
12 KIT-T2 WIRE REPAIR	415-52754-00 WS19X10040	415-52754-00 WS19X10040	415-52754-00 WS19X10040
13 KIT-WIRE REPAIR L1-L2	415-52654-00 WS19X10039	415-52654-00 WS19X10039	415-52654-00 WS19X10039
14 WIRE TIE-STANDARD 7.5 WHITE (x12)	415-52220-00 WR02X11607	415-52220-00 WR02X11607	415-52220-00 WR02X11607
15 KIT-REAR SHROUD (GREY)	415-52743-00 WS31X20222	415-52743-00 WS31X20222	415-52743-00 WS31X20222
16 TRIM RING	415-52356-00 WS31X10061	415-52356-00 WS31X10061	415-52356-00 WS31X10061
17 GROUND WIRE TO J-BOX	415-52669-00 WS19X10038	415-52669-00 WS19X10038	415-52669-00 WS19X10038
18 SCREW-#8-18 B PNT 3/4 S (x5)	415-52238-00 WS02X10084	415-52238-00 WS02X10084	415-52238-00 WS02X10084
19 KIT-T5 SENSOR	415-52444-02 WS17X21223	415-52444-02 WS17X21223	415-52444-02 WS17X21223
20 AIR FILTER	415-52317-00 WS31X10058	415-52317-00 WS31X10058	415-52317-00 WS31X10058
21 CLIP-AIR FILTER COVER (x2)	415-52318-00 WS01X10053	415-52318-00 WS01X10053	415-52318-00 WS01X10053
22 SENSOR (T3A/T3B/T4)	415-52788-00 WS17X10007	415-52788-00 WS17X10007	415-52788-00 WS17X10007
23 CLIP SENSOR (T3B)	415-52704-00 WS02X10079	415-52704-00 WS02X10079	415-52704-00 WS02X10079
24 CLIP SENSOR (T3A/T4) (x2)	415-52698-00 WS02X10078	415-52698-00 WS02X10078	415-52698-00 WS02X10078
25 MASTIC-THERMAL SENSOR (x2)	415-52314-00 WS03X10075	415-52314-00 WS03X10075	415-52314-00 WS03X10075
26 WIRE TIE/PLUG	415-52592-00 WH01X10217	415-52592-00 WH01X10217	415-52592-00 WH01X10217
27 KIT-SENSOR ASSY (T3A/T3B/T4)	415-52511-00 WS17X10011	415-52511-00 WS17X10011	415-52511-00 WS17X10011
28 COVER-ACCESS J- BOX	415-52162-00 WS01X20382	415-52162-00 WS01X20382	415-52162-00 WS01X20382
29 BUSHING-SB875-11 SNAP-IN	239-80406-00	239-80406-00	239-80406-00
30 COVER-FIXED J- BOX	415-52163-00 WS01X20383	415-52163-00 WS01X20383	415-52163-00 WS01X20383
31 BOX-JUNCTION	415-52340-00 WS01X20381	415-52340-00 WS01X20381	415-52340-00 WS01X20381

*Applies to all warranties

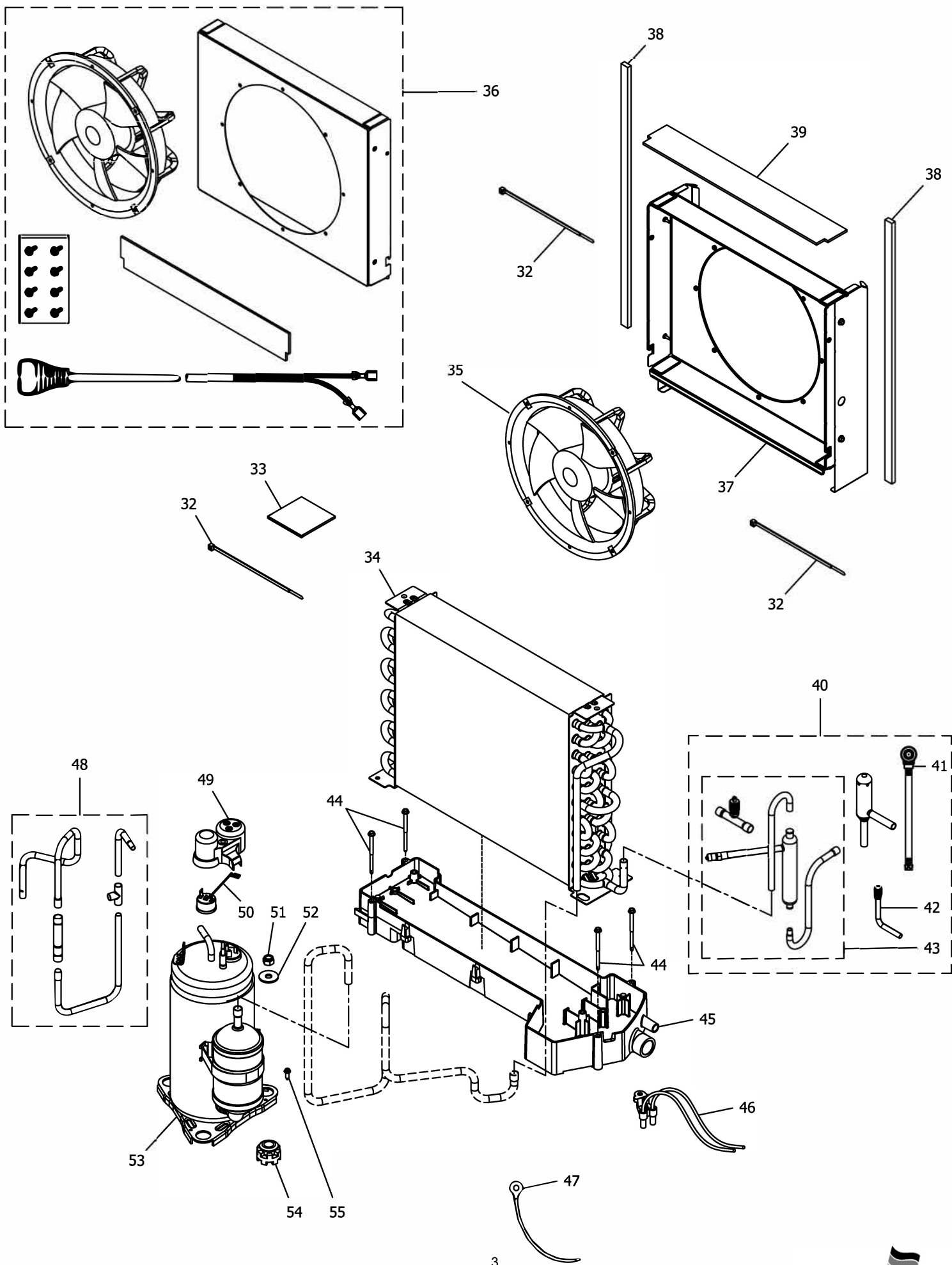

Item Description	Model RE2H50S*	Model RE2H65T*	Model RE2H80T*
32 WIRE TIE-STANDARD 7.5 WHITE (x12)	415-52220-00 WR02X11607	415-52220-00 WR02X11607	415-52220-00 WR02X11607
33 MASTIC-THERMAL SENSOR (x2)	415-52314-00 WS03X10075	415-52314-00 WS03X10075	415-52314-00 WS03X10075
34 KIT-EVAPORATOR	415-52608-00 WS35X20621	415-52608-00 WS35X20621	415-52608-00 WS35X20621
35 KIT-FAN EBMPAPST (W1G200-EC89-91)	415-54514-00	415-54514-00	415-54514-00
36 KIT-HPWH NT4 FAN, SHROUD, AND EXT. HARNESS	415-54515-00	415-54515-00	415-54515-00
37 HOUSING-FAN RE2H(50,65,80)	235-54551-00	235-54551-00	235-54551-00
38 INSULATION-FOAM FAN HOUSING SEAL (x2)	415-52309-00 WS16X10003	415-52309-00 WS16X10003	415-52309-00 WS16X10003
39 INSULATION-FOAM FAN HOUSING & EVAP	415-52310-00 WS16X10002	415-52310-00 WS16X10002	415-52310-00 WS16X10002
40 KIT-EEV VALVE	415-52626-00 WS35X20590	415-52626-00 WS35X20590	415-52626-00 WS35X20590
41 COIL-EEV	415-52627-00 WS17X20589	415-52627-00 WS17X20589	415-52627-00 WS17X20589
42 TUBE ASSY-COMP PROCESS	415-52601-00 WS07X10035	415-52601-00 WS07X10035	415-52601-00 WS07X10035
43 KIT-FILTER DRYER	415-52600-00 WS35X20594	415-52600-00 WS35X20594	415-52600-00 WS35X20594
44 KIT-SCREW#10-32 X 2-1/2 SLOT HEX WASH TY-F ZINC (x4)	415-55336-00	415-55336-00	415-55336-00
45 PAN-CONDENSATE DRAIN	415-52341-00 WS28X20385	415-52341-00 WS28X20385	415-52341-00 WS28X20385
46 KIT-CONDENSATE OVERFLOW	415-52681-00 WS35X20622	415-52681-00 WS35X20622	415-52681-00 WS35X20622
47 WIRE-GROUND COMPRESSOR GRN+Y 5"	415-52197-00 WS19X10034	415-52197-00 WS19X10034	415-52197-00 WS19X10034
48 KIT-DISCHARGE TUBE	415-52653-00 WS35X20591	415-52653-00 WS35X20591	415-52653-00 WS35X20591
49 COVER-COMPRESSOR TERMINAL	415-52229-00 WS31X20404	415-52229-00 WS31X20404	415-52229-00 WS31X20404
50 SENSOR-COMPRESSOR OVERLOAD	415-52301-00 WS08X20405	415-52301-00 WS08X20405	415-52301-00 WS08X20405
51 NUT-HEX 5/16-18 (x3)	415-52298-00 WS02X20444	415-52298-00 WS02X20444	415-52298-00 WS02X20444
52 WASHER-5/16 X 1 FLAT SS (x3)	415-52222-00 WS02X20445	415-52222-00 WS02X20445	415-52222-00 WS02X20445
53 COMPRESSOR	415-52226-00 WS87X20403	415-52226-00 WS87X20403	415-52226-00 WS87X20403
54 GROMMET-COMPRESSOR (x3)	415-52223-00 WR02X22869	415-52223-00 WR02X22869	415-52223-00 WR02X22869
55 SCREW-#8-32 GX IHX 3/8 SCA	415-52235-00 WR01X10757	415-52235-00 WR01X10757	415-52235-00 WR01X10757

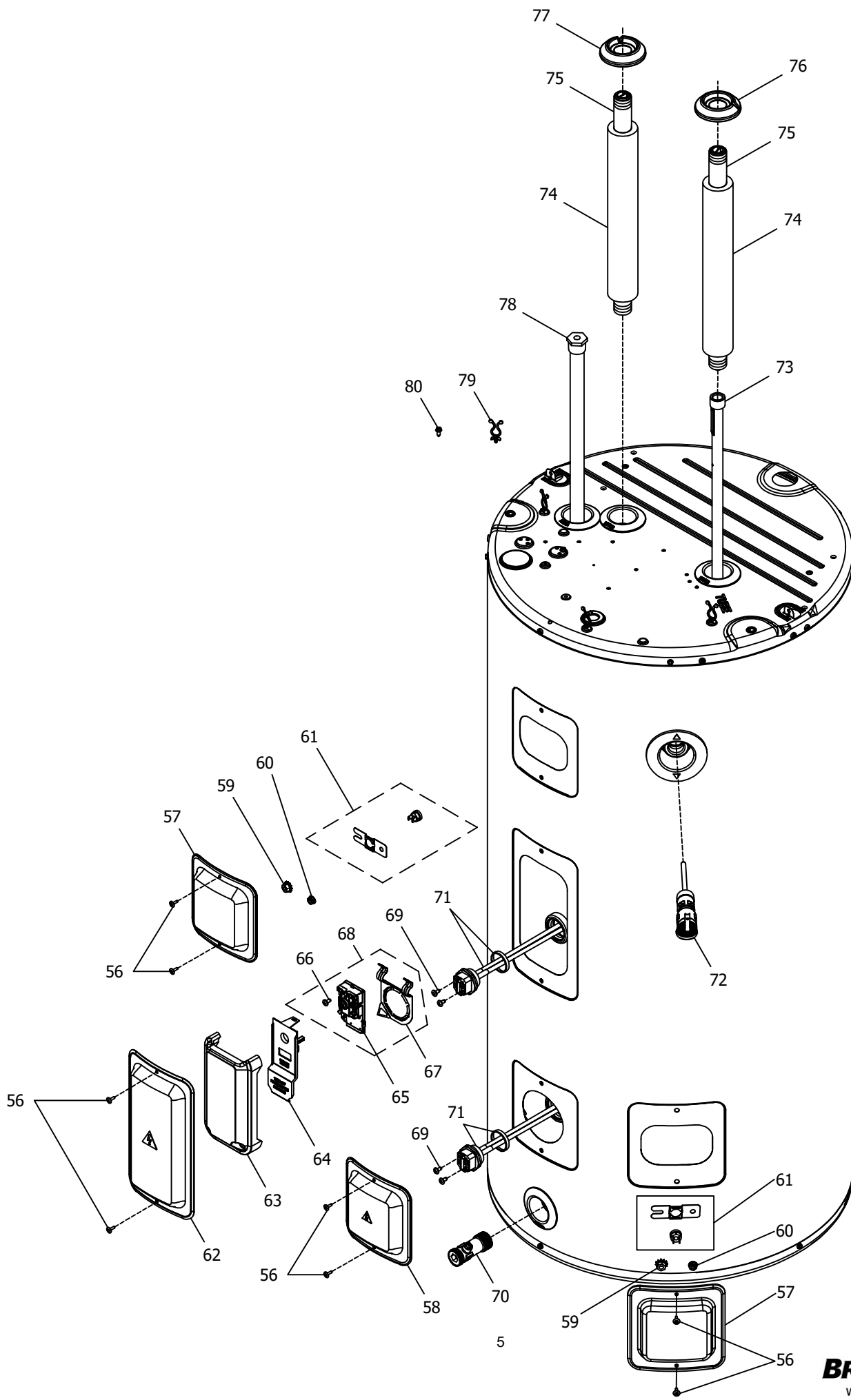

Item Description	Model RE2H50S*	Model RE2H65T*	Model RE2H80T*
56 SCREW-#8-18 AB PNT20 7/16 S (x13)	415-52241-00 WS02X10083	415-52241-00 WS02X10083	415-52241-00 WS02X10083
57 COVER-ELEMENT UPPER/LOWER	239-52376-00	239-52376-00	239-52376-00
58 COVER-ELEMENT LOWER RE2H(50,65,80)	235-52161-00	235-52161-00	235-52161-00
59 NUT-KEPS 1/4-20	239-43372-00	239-43372-00	239-43372-00
60 NUT-HEX LOCKING #10-32	415-52221-00 WS02X21225	415-52221-00 WS02X21225	415-52221-00 WS02X21225
61 KIT-ASSY-SENSOR-T2 & BRACKET	415-52271-00 WS17X20586	415-52271-00 WS17X20586	415-52271-00 WS17X20586
62 COVER-ELEMENT	415-52160-00 WS31X10055	415-52160-00 WS31X10055	415-52160-00 WS31X10055
63 INSULATION-ELEMENT COVER EPS	415-52313-00 WS82X10006	415-52313-00 WS82X10006	415-52313-00 WS82X10006
64 COVER-THERMOSTAT PROTECTOR	415-52170-00 WS34X10026	415-52170-00 WS34X10026	415-52170-00 WS34X10026
65 T-STAT-APCOM	415-52651-00	415-52651-00	415-52651-00
66 SCREW-10-32 PNUP 3/8 S (x4)	415-52287-00 WS02X10076	415-52287-00 WS02X10076	415-52287-00 WS02X10076
67 BRACKET-TSTAT	415-50689-00 WS03X10074	415-50689-00 WS03X10074	415-50689-00 WS03X10074
68 KIT-BRACKET, T-STAT, SCREWS	415-52651-00 WS17X10012	415-52651-00 WS17X10012	415-52651-00 WS17X10012
69 SCREW-#10-32 PNUP 13/32 S (x4)	415-52717-00 WS02X10077	415-52717-00 WS02X10077	415-52717-00 WS02X10077
70 KIT-DRAIN VALVE REPLACEMENT	415-51684-01	415-51684-01	415-51684-01
71 KIT-ELEMENT-240V 4000W INCOLOY W/ GASKET	415-52642-00 WS51X20761	415-52642-00 WS51X20761	415-52642-00 WS51X20761
72 VALVE, TEMP/PRESSURE RELIEF	415-52277-00 WS06X10014	415-52277-00 WS06X10014	415-52277-00 WS06X10014
73 DIPTUBE-PS	415-52374-00 WS08X20361	229-52374-00 WS08X20361	415-52156-00 WS08X20601
74 KIT-INSULATION-NIPPLE 12" (x2)	415-52312-00 WS07X10031	415-52312-00 WS07X10031	415-52312-00 WS07X10031
75 NIPPLE-3/4 NPT X 16 PLASTISERT W/PRE-APPLIED	415-52648-00	415-52648-00	415-52648-00
76 GROMMET-INLET (BLUE)	415-52177-00 WS01X10051	415-52177-00 WS01X10051	415-52177-00 WS01X10051
77 GROMMET-OUTLET (RED)	415-52168-00 WS01X10050	415-52168-00 WS01X10050	415-52168-00 WS01X10050
78 ROD-ANODE	415-47782-06	415-47782-07	415-47782-12
79 CLIP-WIRE TIE BALL 1.629 WHITE NYLON (x6)	415-52288-00 WS02X10073	415-52288-00 WS02X10073	415-52288-00 WS02X10073
80 SCREW-#10-32 GX HXW 7/16 S (x5)	415-52244-00 WS02X10087	415-52244-00 WS02X10087	415-52244-00 WS02X10087



United States

Sales 800-523-2931

Technical Support 800-334-3393

Email techserv@bradfordwhite.com

Warranty 800-531-2111

Email warranty@bradfordwhite.com

Service Parts 800-538-2020

Email parts@bradfordwhite.com

Canada

Sales & Technical Support 866-690-0961 905-203-0600

Fax 905-636-0666

Warranty bwccwarranty@bradfordwhite.com

Technical Support bwccotech@bradfordwhite.com

Service Parts orders@bradfordwhitecanada.com

Orders ca.orders@bradfordwhite.com

For U.S. and Canada field service,
contact your professional installer or
local Bradford White sales representative.

International

General Contact international@bradfordwhite.com