



# 12,000 BTU/H ONE-WAY CASSETTE HEAT PUMP SYSTEM

SUBMITTAL COVER SHEET

PROJECT NAME \_\_\_\_\_

LOCATION \_\_\_\_\_



ARCHITECT \_\_\_\_\_

ENGINEER \_\_\_\_\_

CONTRACTOR \_\_\_\_\_

REFERENCE \_\_\_\_\_

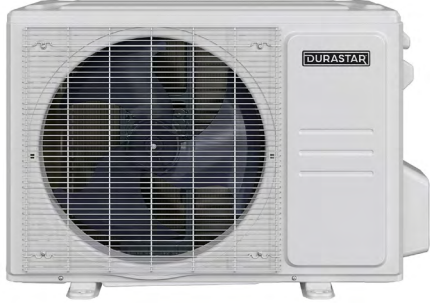
SUBMITTED BY \_\_\_\_\_ DATE \_\_\_\_\_

Indoor Unit (IDU): DRAL12F1A	Outdoor Unit (ODU): DRA1U12S1B	Wireless Remote Control
		

## PRODUCT FEATURES

- Low ambient heating down to -13°F
- Low ambient cooling down to 5°F
- Wireless Remote Control with "Follow Me" Technology
- Variable Speed Inverter Compressor
- Auto Restart
- Sleep Mode
- Turbo Mode
- Quiet operation
- 46°F Freeze Protection
- Included base pan heater
- Refrigerant leak detection
- Anti-corrosive fin coating
- Grille included

CAPACITIES		
Cooling Capacity (BTU/hr)	Rated at 95°F <sup>1</sup>	12000
	Minimum	4000
	Maximum	13200
Heating Capacity (BTU/hr)	Rated at 47°F <sup>2</sup>	12500
	Rated at 5°F <sup>3</sup>	7600
	Minimum	3700
	Maximum	12800

SYSTEM DATA	
Refrigerant Type	R-410A
Refrigerant Charge (oz.)	38.1
Design Pressure (PSIG)	550/340
Indoor/ Outdoor Coil Coating	Golden Fin Coating

EFFICIENCY DATA	
SEER2	22.00
EER2	12.60
HSPF2	9.80
SEER	21.20
EER	12.60
HSPF	10.80
COP at 47°F	3.2
COP at 5°F	2.1



Specifications are subject to change without notice.  
 © 2023 Ferguson Enterprises LLC  
 www.durastar.com



# 12,000 BTU/H ONE-WAY CASSETTE HEAT PUMP SYSTEM

SPECIFICATIONS

LINE SET REQUIREMENTS	
Connection Type	Flare
Liquid	Ø1/4" (Ø6.35mm)
Gas	Ø1/2" (Ø12.7mm)
Pre-Charge Length	25'
Minimum Length	10'
Maximum Length	82'
Maximum Height Differential	33'
Additional Refrigerant (oz./ft)	0.16

OUTDOOR UNIT		
Unit Dimensions	Width	30-1/8"
	Depth	11-15/16"
	Height	21-7/8"
Carton Dimensions	Width	34-15/16"
	Depth	13-1/4"
	Height	24"
Net Weight	63.7 lbs.	
Gross Weight	69.0 lbs.	
Cooling Operating Temperature	5°F - 122°F	
Heating Operating Temperature	-13°F - 75°F	
Voltage/Phase/Frequency	208-230V, 1 Phase, 60 Hz	
Voltage Range	187-253V	
Recommended Breaker (Amps)	15	
Minimum Circuit Ampacity (Amps)	13	
Communication Wire Size	14*4 AWG Stranded	
Rated Current - Cooling (Amps) <sup>1</sup>	4.17	
Rated Current - Heating (Amps) <sup>2</sup>	4.85	
Sound Pressure (dB(A))	53.5	

<sup>1</sup> AHRI Rated at 95°F (AFull).

<sup>2</sup> AHRI Rated at 47°F (H1Full).

<sup>3</sup> AHRI Rated Capacity at 5°F (H42)

INDOOR UNIT		
Unit Dimensions	Width	50-5/16"
	Depth	13-13/16"
	Height	9"
Carton Dimensions	Width	57-5/8"
	Depth	22-1/2"
	Height	22-1/2"
Net Weight	61 lbs.	
Gross Weight	83 lbs.	
Indoor Unit Air Flow (CFM)	Low	247
	Medium	282
	High	312
Drain Port O.D.	1"	
Drain Pump Lift	20.8"	
Recommended Breaker (Amps)	15	
Sound Pressure (dB(A))	Low	34.5
	Medium	38.5
	High	40.5

COMPRESSOR	
Type	DC Rotary Inverter
Oil Type	Ester Oil VG74
Oil Charge (oz.)	10.5 (310 ml)



# 12,000 BTU/H ONE-WAY CASSETTE HEAT PUMP SYSTEM

IDU DIMENSIONS - DRAL12F1A

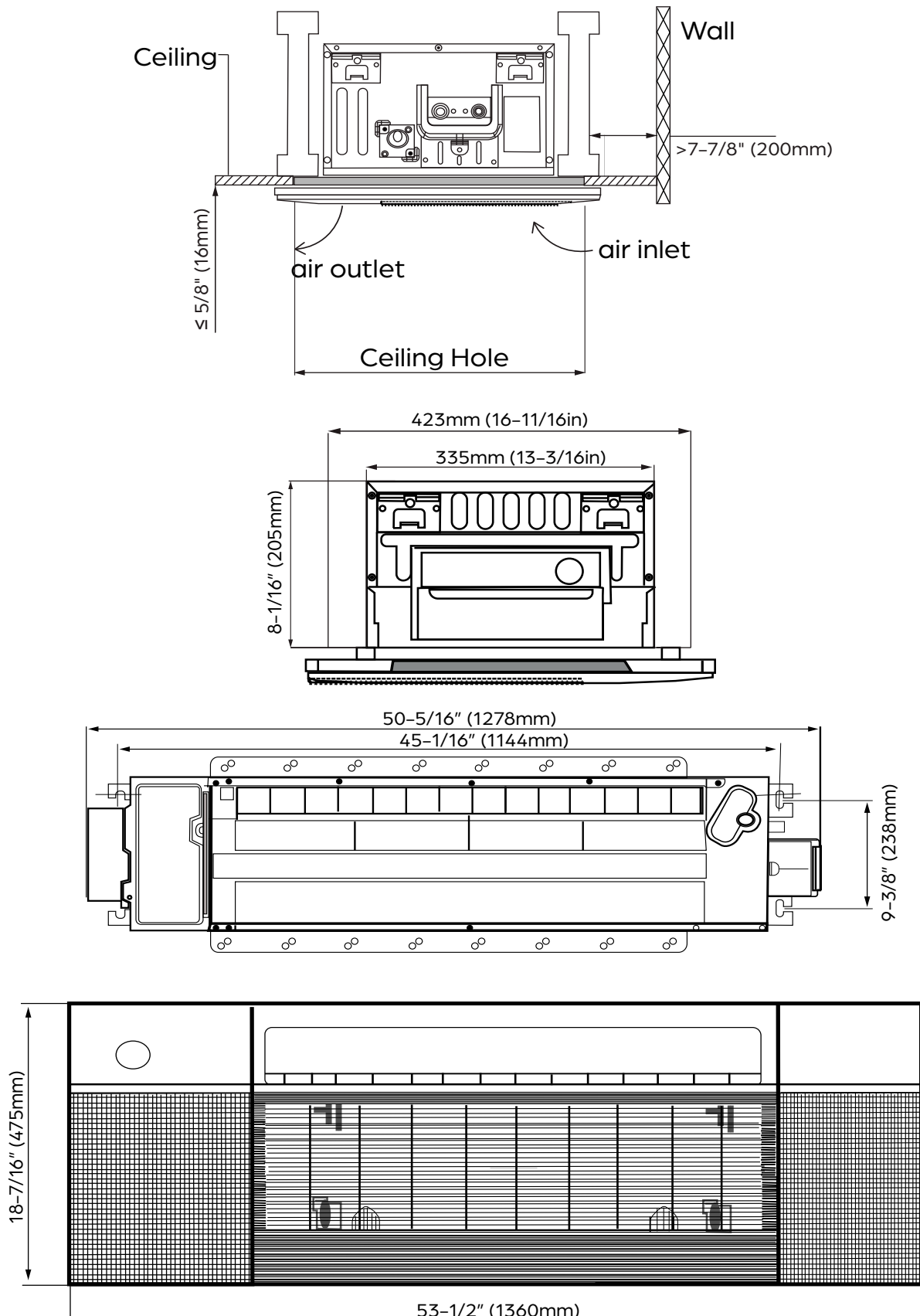



# 12,000 BTU/H ONE-WAY CASSETTE HEAT PUMP SYSTEM

ODU DIMENSIONS - DRA1U12S1B

## Clearances

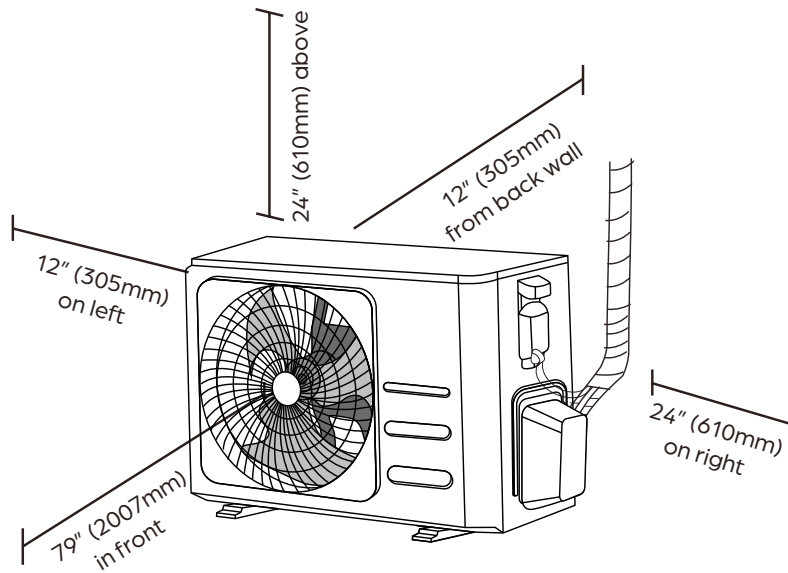

## Dimensions

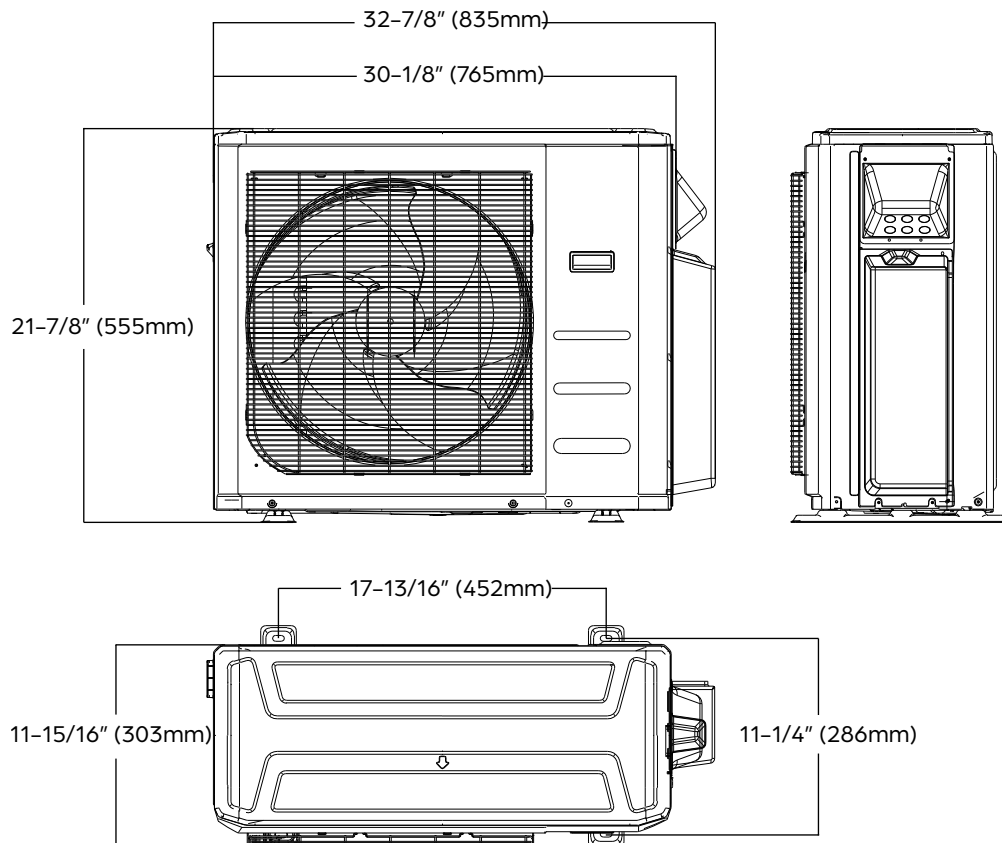

## NOTE

- Illustrations in this document are for explanatory purposes. The actual shape of your mini-split equipment may vary slightly.